

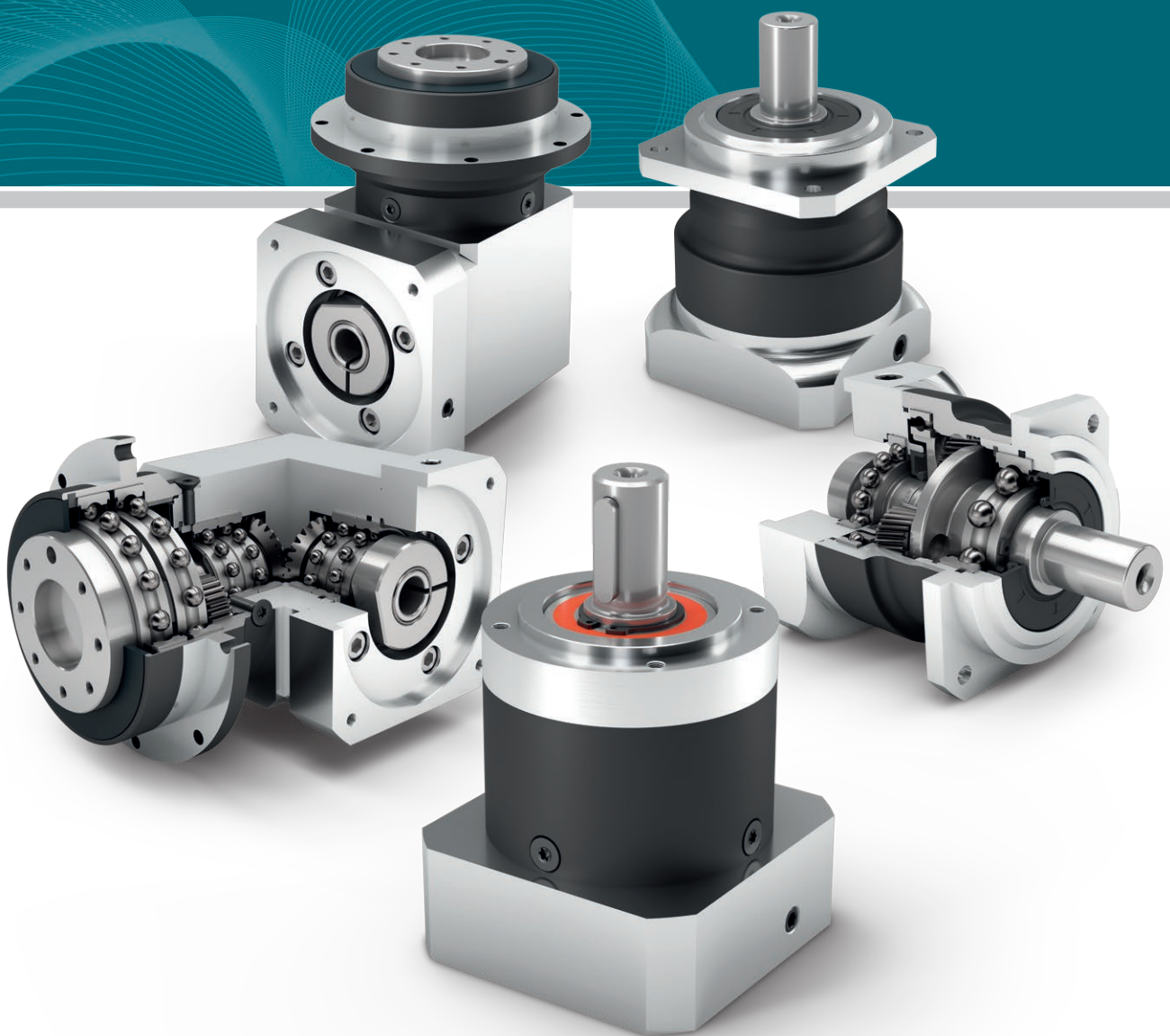

综合样本 高精度变速器
Precision gearbox catalog



高强度、高精度。
良好的合作伙伴关系。

我们始终致力于能够以有限的零件系列组合出近乎无穷多的减速机类型，并希望这一过程能够足够简便。

这可以通过我们对应用需求的理解、发挥减速机模块的智能性并借助个性化研发在短期内制定完美解决方案来实现。

我们的减速机不断完善。
坚实可靠！始终如一！信守承诺！

**Impress with power and precision.
Inspire with partnership.**

“We’re fascinated by the way in which a modest number of parts can be used to build a seemingly infinite number of gearbox variants, all the while making it appear like it’s quite simple.

We achieve this because we understand the application, exploit the intelligence of our modular gearbox system and develop custom solutions within a just a short time.

Our gearboxes deliver the power you need:
Reliably. Lifelong. And that’s a promise!”



Thomas Herr
执行董事
Managing Partner

Bernd Neugart
执行董事
Managing Partner

超强动力，高精度以及良好的合作伙伴关系是本公司80多年来始终贯彻执行的经营理念。

我们提供的产品系列包括许多创新的成熟技术和可信赖的减速机解决方案。

我们提供17种高精度、高性能的标准系列行星减速机，它们都已经得到了广泛的应用。

作为您技术上的合作伙伴，我们也会提供定制的方案；专业的客户定制减速机。

如果您对我们的产品和服务有任何的问题，请及时与我们联系，我们将竭诚为您服务。

Power, precision and partnership – these values characterize our business philosophy and our work, and have for over 80 years.

Our offered product range includes numerous innovative, technologically mature, and highly reliable gearbox solutions. The 17 standard planetary gearbox series we offer cover a wide range of applications – from the highest precision to the highest performance.

As a technology partner, we also provide customized solutions; specialized, custom designed gearboxes.

Please contact us with any questions about our products or services – we appreciate every opportunity to assist and meet your automation, precise motion and power transmission requirements.

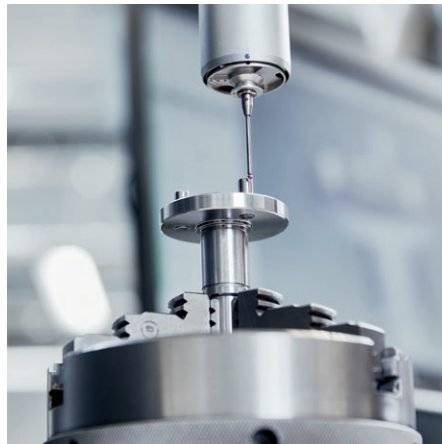



页
Page 1

➤ 编者说明

➤ Editorial



页
Page 3

➤ 目录

➤ Table of contents



页
Page 6

➤ 用户定制减速机方案

➤ Custom made gearboxes



页
Page 7

➤ 高品质

➤ Quality



页
Page 8

➤ 服务 · 工具与培训

➤ Tools and Trainings



页
Page 10

➤ 对于决策者

➤ For decision-makers



页
Page 12

➤ 功率等级

➤ Performance classes



页
Page 14-67

➤ 经济型减速机

➤ The Economy gearboxes



页
Page 68-109

➤ 精密型减速机

➤ The Precision gearboxes



页
Page 110

➤ 卫生型设计减速机

➤ The Hygienic Design gearbox

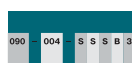

页
Page 116

➤ 产品代码

➤ Product code



页
Page 120

➤ 输出法兰规格

➤ Output flange design



页
Page 124

➤ 输入系统规格

➤ Input design



页
Page 126

➤ 配件

➤ Accessories

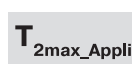

页
Page 128

➤ 技术背景

➤ Technical background



页
Page 130

➤ 联系

➤ Contact

PLE
页
Page 14



经济型减速机

其优势在于：此款行星减速机即使在最高转速时也能达到最高效率

The Economy gearboxes

Unparalleled: This planetary gearbox maintains its maximum efficiency even at the highest speeds

PLQE
页
Page 20

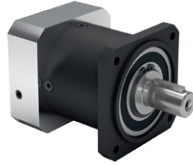

一款可便捷安装的行星减速机。发热量低，可承受较高的力

The easy to install planetary gearbox absorbs high forces with low heat generation

PLPE
页
Page 26

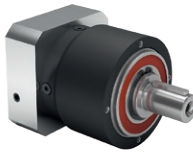

经济型行星减速机，发热量低

The cost effective planetary gearbox with the best torque-low heat performance

PLHE
页
Page 32

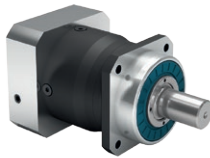

这款行星减速机的进步之处在于：集高精度和经济性于一身

This is progress: In this planetary gearbox, precision and cost effectiveness meet

PLFE
页
Page 38



结构最短的行星减速机，扭转刚度极高，采用法兰输出轴

The shortest planetary gearbox with the highest torsional stiffness and flange output shaft

WPLE
页
Page 44

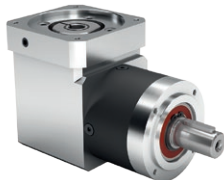

直角行星减速机，轻巧，经济性较高

The versatile right angle planetary gearbox with lower weight and appealing cost effectiveness

WPLQE
页
Page 50



直角行星减速机，带方形通孔输出法兰，安装灵活，适用于承载力很大的工况中

The right angle planetary gearbox with universal output flange – flexible installation options and for high forces

WPLPE
页
Page 56

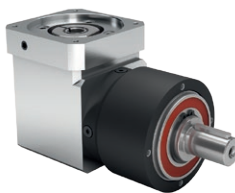

经济型直角行星减速机，适用于承载力很大的工况中，可进行多面安装，终生润滑，免维护





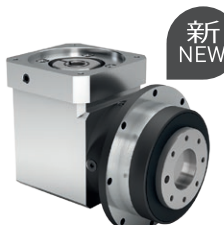

The economical right angle planetary gearbox for particularly high forces – flexible installation options and lifetime lubrication

WPLFE
页
Page 62



最短的直角行星减速机，配有法兰输出轴，扭转刚度极高

The shortest right angle planetary gearbox with flange output shaft and maximum torsional stiffness

<p>PSBN 页 Page 68</p>	 <p>新 NEW</p>	<p>精密型减速机</p> <ul style="list-style-type: none"> 高性能精密减速机 配有高精度斜齿 驱动运行时安静无噪音 	<p>The Precision gearboxes</p> <ul style="list-style-type: none"> The high-performance precision planetary gearbox with helical teeth for a particularly quiet drive
<p>PSN 页 Page 74</p>		<ul style="list-style-type: none"> 斜齿高精度减速机能够实现噪音极低的同步运行，轴承负载能力强 	<ul style="list-style-type: none"> The helical-toothed precision planetary gearbox for low-noise operation and high bearing loads
<p>PLN 页 Page 80</p>		<ul style="list-style-type: none"> 这款完全密封的直齿行星减速机能够提供极高的效能，且不会损失必要的刚性 	<ul style="list-style-type: none"> The perfectly sealed straight-toothed planetary gearbox delivers the maximum performance without ever losing the required stiffness
<p>PSFN 页 Page 86</p>		<ul style="list-style-type: none"> 负载量最高的精密减速机 运行时十分安静 采用法兰输出轴 	<ul style="list-style-type: none"> The precision planetary gearbox for maximum loads with particularly quiet drive and flange output shaft
<p>PLFN 页 Page 92</p>		<ul style="list-style-type: none"> 负载极大的精密减速机 且性能极高 安装便捷 	<ul style="list-style-type: none"> The precision planetary gearbox for maximum loads and the highest performance – fast and easy to install
<p>WPLN 页 Page 98</p>		<ul style="list-style-type: none"> 直角减速机 配有准双曲面齿轮，因此运行时十分安静 	<ul style="list-style-type: none"> The versatile right angle gearbox with spiral teeth for a quiet drive
<p>WGN 页 Page 104</p>		<ul style="list-style-type: none"> 空心轴式输出的准双曲面齿轮减速机—噪音低，以涨紧力传递的方式进行安装 	<ul style="list-style-type: none"> The spiral-toothed right angle gearbox with hollow shaft – low noise levels and force-fit installation

卫生型设计减速机

The Hygienic Design gearbox

<p>HLAE 页 Page 110</p>		<ul style="list-style-type: none"> 独一无二的行星减速机 采用经过认证的卫生设计 – 安全 清洁流程的理想之选 	<ul style="list-style-type: none"> The unique planetary gearbox with certified hygienic design – ideal for reliable cleaning processes
---------------------------------------	---	---	---



创新并且独特： 定制减速机

坚固的结构设计及高性能、特殊的结构需求。食品级的认证或独特的设计：本公司可以满足客户在机械领域中的各种复杂要求。

高素质的技术工程师设计变速器系统并解决变速器各种问题。服务、成本和质量恰到好处。

创新优势：本公司将长期的专业经验以及不断的研发成果运用到客户解决办法中。

借助现代工艺及设计工具可实现设备制造（例如打印机、操作系统、压铸机或涂装机械手设备）、医学技术及模型制造等领域中的各项应用。开创崭新的未来。

Innovative and individual: Our custom made gearboxes.

Compact form and high performance, special construction requirements, food grade certification or individual design: We fulfill even your most complex requirements – in all sectors of machine building.

The qualified specialists of our engineering department design gearbox solutions and systems. According to your performance, price and quality needs.

Your benefit from innovation: We utilize our experience and at the same time take advantage of new developments, integrating them into our customer solutions.

Using modern design and development tools, applications from all areas of system design (for instance, printing presses, handling systems, die-cast machines and robot painting systems), medical engineering and model building are realized. For new perspectives.





高质量的产品。

顾客满意是本公司的终极目标，产品质量和服务是我们的首要任务。
本公司的质量-环保理念保证并保持了我们在国际市场上不断地取得巨大成功。

本公司在产品质量、技术支持和服务上的高标准要求得到了国际认可：在全世界所有重要的工业国家中我们拥有超过70家代理和分支机构。

本公司只在德国进行产品制造。在美国和中国的组装厂可以满足不同地区的需求并保证供货时间和货物调度的灵活性。



Power at a high level: Our quality.

Your satisfaction is our measuring stick – that's why the quality of our products and services is always our top priority. With our quality and environmental policy we secure and expand our economic success in the international marketplace.

Our high standard in product quality, support and service is appreciated internationally: With over 70 representatives and branches, we are represented in all important industrial nations.

We manufacture our products exclusively in Germany. In the USA and China, our assembly factories serve regional markets, guaranteeing a high level of flexibility for adaptations as well as the shortest delivery times.





**尽情享用：
Neugart 计算程序 – NCP**

使用 Neugart 计算程序 (NCP)，您可简单几步便实现最佳的电机与变速器组合，同时还能节省采购和运转费用。在整个使用期间，直观的用户界面将始终伴随用户。设计使得您无需长时间熟悉整个过程。可立即上手使用。

通过 NCP 您可查询到市场上几乎所有常见的电机和各种应用，如齿轮齿条、滚珠丝杆、皮带、输送带、转盘、曲轴和绕线机。每个阶段都有动态数据和负载的图示。您便可实时关注所使用的组件是否合适。

优点概要：

- 界面友好—输入&输出值一目了然
- 免费下载设计工具
- 可离线使用—即使无管理员权限
- 可轻松输入复杂的预定义应用
- 包括 11,000 余种电机的庞大电机数据库
- 输入值的可信度测试
- 可记录所有计算步骤
- 所有信息均有七种不同语言可选
- 在线获取尺寸图和 CAD 文件

Neugart 公司将定期提供免费的 NCP 培训。
请联系：sales@neugart.com

**Simply greater benefit:
Neugart Calculation Program – NCP**

The Neugart Calculation Program (NCP) lets you assemble the optimal motor and gearbox combination with just a few clicks – and thus save acquisition and operating costs.

The intuitive user interface guides the user through the application. The look and feel design can be learned in just a short time. You can start straight away.

NCP gives you access to virtually all of the conventional motors on the market and a large number of applications like pinions, spindles, belts, conveyors, rotary tables, slider cranks, and winders. Dynamics and load data are depicted as graphs in each stage. You can then see in real time whether the components you have selected are suitable or not.

Your benefits at a glance:

- User friendly – input and output values at a glance
- Free design tool available for download
- Offline mode – also without administrator rights
- Simple input options for complex, predefined applications
- Extensive database containing over 11,000 motors
- Plausibility check on the entered values
- Documentation of all calculation steps
- Information can be output in seven different languages
- Online access to dimension sheets and CAD files

Neugart offers free NCP training courses at regular intervals.
Please contact us at sales@neugart.com

最新在线服务, 新的选择: Tec Data Finder – TDF

仅需几步操作, Tec Data Finder (TDF) 便可为您生成变速器的所有相关信息。其中包括呈现在尺寸图中的特定技术和几何数据, 以及所有常见格式的 CAD 模型。

同时, 变速器的几何形状可直接在特定的电机上进行调整和调试。这需要借助全面的电机数据库或者输入对应的连接尺寸。除此之外, 无需预选特定的电机便可从尺寸图和 CAD 数据库中直接下载变速器数据。

New online services, new options: Tec Data Finder – TDF

With just a few clicks, the Tec Data Finder (TDF) generates all of the information relevant to your gearbox. This includes the specific technical and geometrical data in the form of a dimension sheet as well as the CAD models in all of the usual formats.

At the same time, the gearbox geometry can be adapted and tuned directly to your specific motor. This is based on a comprehensive motor database or on manual entries of individual connection measurements. In addition, the gearbox data can also be downloaded directly from the dimension sheet and CAD database without the advance selection of a specific motor.



优点概要:

- 界面友好—可通过下拉框输入
- 免费的在线工具
- 全面的电机数据库 (超过 11,000 种电机)
- 电机-变速器法兰-几何形状的可信度测试
- 高级用户访问—访问更快速
- 完整的产品密钥—快速的报价查询
- 所有信息均有七种不同语言可选

Your benefits at a glance:

- User friendly – entries via dropdown fields
- Free online tool
- Comprehensive motor database (over 11,000 motors)
- Plausibility check on motor and gearbox flange geometries
- Power user access – for even faster access
- Output of the complete product code – for fast quote requests
- Information can be output in seven different languages

如欲了解有关 NCP和TDF工具的信息, 请访问:
www.neugart.com

The NCP and TDF tools can be found on our website:
www.neugart.com



**注重细节，打造完美：
公司产品和我们的服务。**

公司提供各种服务项目-通过Neugart官网NCP和TDF工具，您可以进行尺寸图和产品搜索，为您提供标准的减速机选型参数。

公司在各个国家都设有分公司。公司的信息网络以及所使用的经营软件不但可以保证各个分公司可以顺利地进行通讯往来，并提供最佳的合作经营流程。

性能强，效率高且技术创新：我公司保证在变速器技术方面为您提供先进的解决方案，以及质量高，经济性的产品。



**Perfection in every detail:
Our products and our service.**

We accompany you with a wide range of services – from NCP, our free calculation tool, to the NEUGART dimension sheet and product finders to our integrated, certified claims management.

We are represented in all important markets with local companies. Our internal information network and the business software we use ensure smooth internal communication and optimally coordinated business processes.

Powerful, efficient and innovative: We create forward-looking solutions in gearbox technology – high quality at reasonable prices.

另一项决策：
Neugart – 最佳原因.

几十年来，Neugart始终利用高科技和创新技术，持续研发以及高精密的制造技术获得了全世界客户的信赖。

我公司在精密加工变速器，特殊变速器制造以及按照客户要求生产齿轮部件方面积累了丰富的丰富经验和专业技术，产品在国内和国际市场上供不应求。

凭借于高效率-德国制造：您可以在公司系列产品中找到您需要的产品。

当然，公司还有更多的优点值得您选择Neugart产品。

Decidedly different:
Neugart – for good reason.

Neugart distinguishes itself with advanced, innovative technology, with high-precision production technology and has been doing so for decades. Worldwide, renowned customers put their trust in our vast experience.

Our precise planetary gearboxes and our experience in the construction of custom made gearboxes are highly sought after in national and international markets.

Put your trust in the highest level of performance – Made in Germany: In our well-balanced portfolio you will find the right product for your needs.

We can provide you with good reasons to make a decision for Neugart now.



高效、功能强劲：
高精度行星齿轮传动变速器。

无论在机床、铸塑机中，还是在包装机、印刷机和纺织器械中，或在自动控制技术、喷涂机械手设备中：我们的高精度行星齿轮传动变速器对于各种不同的应用领域将是最好的选择。此外本公司还提供非标准类的器械。

此外本公司还提供非标准类的器械。

程序概览。

在此概览中您可以找到产品的重要特性。

- 标准
- • • • 优秀
- **Standard**
- • • • **Excellent**

经济型减速机	额定输出扭矩	回程间隙	轴承最大承载能力	防护等级	运行噪音	输入转速	抗扭刚性	传动比多样性
Economy gearboxes	Nominal output torque	Backlash	Bearing load	Protection class	Running noise	Input speeds	Torsional stiffness	Wide range of ratios
 PLE	• •	• •	•	• •	• •	• • • •	• •	• • • •
 PLQE	• •	• •	• •	• •	• •	• • • •	• •	• • • •
 PLPE	• •	• •	• •	• •	• •	• • • •	• •	• • •
 PLHE	• •	• •	• • •	• • •	• •	• • •	• •	• • •
 PLFE	• •	• •	• •	• •	• •	• • • •	• • • •	• • •
 WPLE	•	•	•	• •	•	• • •	•	• • • •
 WPLQE	•	•	• •	• •	•	• • •	•	• • • •
 WPLPE	•	•	• •	• •	•	• • •	•	• • •
 WPLFE	•	•	• •	• •	•	• • •	• • • •	• • •

Powerful and efficient: Our precision planetary gearboxes.

Whether in machine tools or die-casting machines, in packaging, printing and textile machines, in automation technology or in robotic painting systems: Our precision planetary gearboxes are ideally suited for numerous applications.

We offer much more than just standard.

Our program at a glance.

In this overview you will find a direct comparison of the key features of our products.

- 标准
- • • • 优秀
- Standard
- • • • Excellent

高精度减速机	额定输出扭矩	回程间隙	轴承最大承载能力	防护等级	运行噪音	输入转速	抗扭刚性	传动比多样性
Precision gearboxes	Nominal output torque	Backlash	Bearing load	Protection class	Running noise	Input speeds	Torsional stiffness	Wide range of ratios
 PSBN	• • • •	• • • •	• •	• • •	• • • •	• • • •	• • •	• • •
 PSN	• • • •	• • • •	• • •	• • •	• • • •	• • •	• • •	• • •
 PLN	• • • •	• • • •	• • •	• • •	• •	• •	• • •	• • •
 PSFN	• • • •	• • • •	• • • •	• • •	• • • •	• • •	• • • •	• •
 PLFN	• • • •	• • • •	• • • •	• • •	• •	• •	• • • •	• •
 WPLN	• • •	• • •	• • •	• • •	• • •	•	• •	• •
 WGN	• • •	• • •	• • •	• • •	• • •	•	• •	•
卫生型设计减速机	额定输出扭矩	回程间隙	轴承最大承载能力	防护等级	运行噪音	输入转速	抗扭刚性	传动比多样性
Hygienic Design gearbox	Nominal output torque	Backlash	Bearing load	Protection class	Running noise	Input speeds	Torsional stiffness	Wide range of ratios
 HLAE	• •	• •	•	• • • •	• •	• • •	• •	• • •

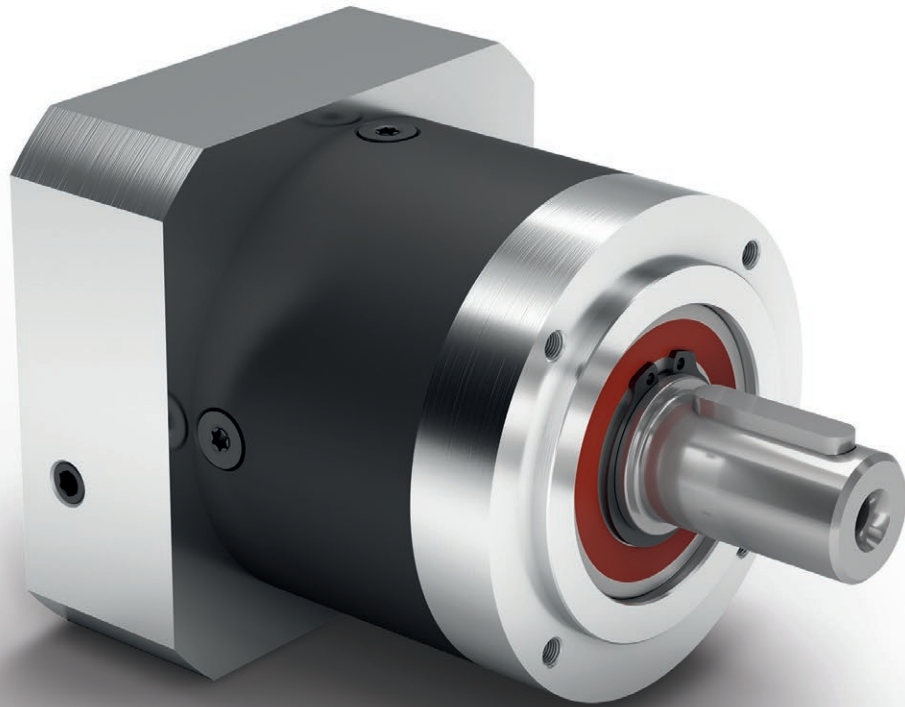

PLE

其优势在于：此款行星减速机即使在最高转速时也能达到最高效率

PLE 系列是我们取得成功的基石。该系列产品极轻、性能十分强劲，且由于其低摩擦损耗轴承设计和优化的润滑功能，十分适用于高标准的生产工况。一款真正强效且价格合理的产品。

Unparalleled: This planetary gearbox maintains its maximum efficiency even at the highest speeds

The **PLE** is perhaps the basis of our success. It is notably light, extremely powerful, yet suitable for complex production cycles due to its low-friction bearing design and optimized lubrication. A genuine powerhouse at an attractive, fair price.

- + 可安装在任意位置
- + 输入法兰可适配特殊的电机
- + 终生润滑，因此免维护
- + 旋转方向同向
- + 输出轴样式多样
- + 优化转动惯量的锁紧系统
- + 精确啮合

- + For any mounting position
- + Individual adaptation of the input flange to the motor
- + Lifetime lubrication for maintenance-free operation
- + Equidirectional rotation
- + Wide range of output shaft designs
- + Clamping systems with optimized mass moment of inertia
- + Precise gearing

1 轻盈但强劲

PLE 系列因其超出平均水平的重量与扭矩的比值而备受青睐，它比传统的驱动装置轻大约 25%。因此也实现了极高的动态灵活性，达到了多轴系统中所要求的水平。

2 高效且可靠

性能强劲，价格合理：这一优势也体现在 **PLE** 行星减速机上。这款产品高效且节能，实现了低廉的采购成本与高性能的完美结合。

3 最高转速时放热量仍很低

凭借其低摩擦损耗轴承设计和优化的润滑功能，**PLE** 在极端环境条件下的表现仍旧非常出色。低放热量确保能在长时间保持高转速的同时不降低性能。

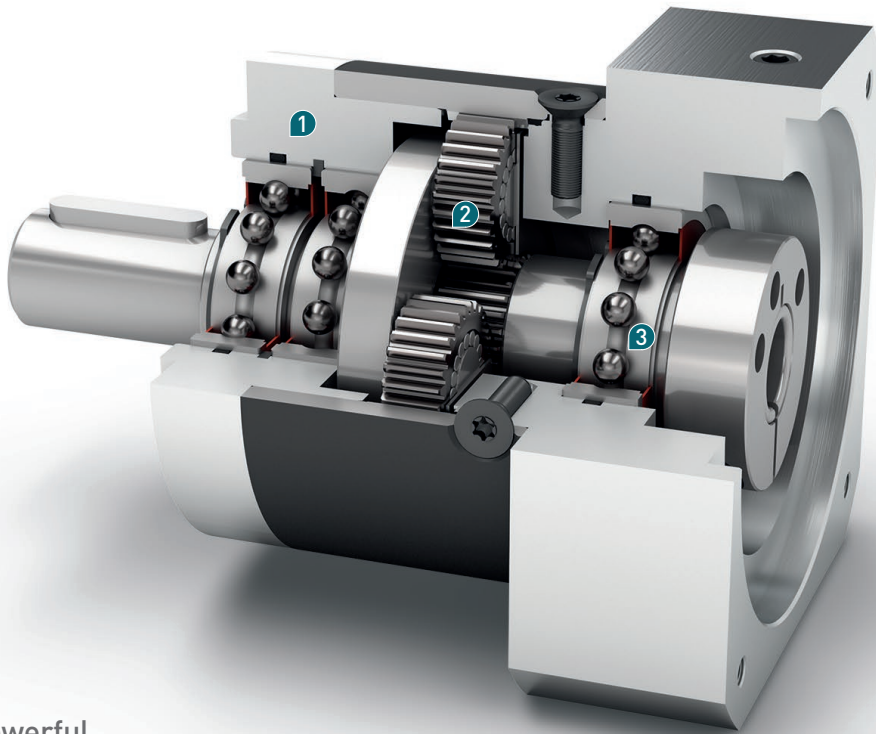

1 Light, but powerful

The **PLE** excels with its above-average weight to torque ratio, and it is 25% lighter than comparable conventional drives. You accordingly benefit from the highest dynamics needed for multiple axis systems.

2 Efficient and reliable

High performance at a fair price: This principle also applies to our **PLE** planetary gearbox. It is powerful, yet efficient, and delivers a high performance for attractive acquisition costs.

3 Low heat generation at the highest speeds

Even in extreme situations, the **PLE** will never let you down thanks to its low-friction bearing design and optimized lubrication. The low heat generation allows a continuous high speed without sacrifice to performance.

Code	减速机参数	Gearbox characteristics			PLE040	PLE060	PLE080	PLE120	PLE160	z ⁽¹⁾
	使用寿命	Service life	t _L	h	30.000					
	满载时效率 ⁽²⁾	Efficiency at full load ⁽²⁾	η	%	98					1
97					2					
92					3					
	最低工作温度	Min. operating temperature	T _{min}	°C	-25					
	最高工作温度	Max. operating temperature	T _{max}		90					
	防护等级	Protection class			IP 54					
S	标准润滑	Standard lubrication			润滑脂 / Grease					
F	食品级润滑	Food grade lubrication			润滑脂 / Grease					
L	低温润滑 ⁽³⁾	Low temperature lubrication ⁽³⁾			润滑脂 / Grease					
	安装位置	Installation position			任意 / Any					
S	标准回程间隙	Standard backlash	j _t	arcmin	< 15	< 10	< 7	< 7	< 6	1
					< 19	< 12	< 9	< 9	< 10	2
					< 22	< 15	< 11	< 11	-	3
	抗扭刚度 ⁽²⁾	Torsional stiffness ⁽²⁾	c _g	Nm / arcmin	0,7 - 1,0	1,7 - 2,3	4,3 - 5,8	10,8 - 14,5	31,0 - 37,5	1
					0,8 - 1,0	1,9 - 2,3	4,7 - 5,8	11,7 - 14,5	30,5 - 37,5	2
					0,8 - 1,0	1,8 - 2,3	4,5 - 5,8	11,2 - 14,5	-	3
	减速机重量	Gearbox weight	m _G	kg	0,35	0,9	2,1	6	18	1
					0,45	1,1	2,6	8	22	2
					0,55	1,3	3,1	10	-	3
S	标准的箱体表面	Standard surface			箱体: 钢 - 氮碳共渗和后氧化处理 (黑色) Housing: Steel - nitrocarburized and post-oxidized (black)					
	运行噪音 ⁽⁴⁾	Running noise ⁽⁴⁾	Q _g	dB(A)	58	58	60	65	70	
	基于减速机输入法兰的最大弯矩 ⁽⁵⁾	Max. bending moment based on the gearbox input flange ⁽⁵⁾	M _b	Nm	3	8	16	40	140	
	电机法兰精度	Motor flange precision			DIN 42955-N					

输出轴载荷	Output shaft loads			PLE040	PLE060	PLE080	PLE120	PLE160	z ⁽¹⁾
20,000 h 的径向力 ⁽⁶⁾⁽⁷⁾	Radial force for 20,000 h ⁽⁶⁾⁽⁷⁾	F _{r20.000h}	N	200	400	750	1750	5000	
20,000 h 的轴向力 ⁽⁶⁾⁽⁷⁾	Axial force for 20,000 h ⁽⁶⁾⁽⁷⁾	F _{a20.000h}		200	500	1000	2500	7000	
30,000 h 的径向力 ⁽⁶⁾⁽⁷⁾	Radial force for 30,000 h ⁽⁶⁾⁽⁷⁾	F _{r30.000h}		160	340	650	1500	4200	
30,000 h 的轴向力 ⁽⁶⁾⁽⁷⁾	Axial force for 30,000 h ⁽⁶⁾⁽⁷⁾	F _{a30.000h}		160	450	900	2100	6000	
静态径向力 ⁽⁷⁾⁽⁸⁾	Static radial force ⁽⁷⁾⁽⁸⁾	F _{r Stat}		200	700	1250	2000	5000	
静态轴向力 ⁽⁷⁾⁽⁸⁾	Static axial force ⁽⁷⁾⁽⁸⁾	F _{a Stat}		240	800	1600	3800	11000	
20,000 h 倾斜力矩 ⁽⁶⁾⁽⁸⁾	Tilting moment for 20,000 h ⁽⁶⁾⁽⁸⁾	M _{K20.000h}	Nm	5	14	31	101	474	
30,000 h 倾斜力矩 ⁽⁶⁾⁽⁸⁾	Tilting moment for 30,000 h ⁽⁶⁾⁽⁸⁾	M _{K30.000h}		4	12	27	86	398	

转动惯量	Moment of inertia			PLE040	PLE060	PLE080	PLE120	PLE160	z ⁽¹⁾
转动惯量 ⁽²⁾	Mass moment of inertia ⁽²⁾	J	kgcm ²	0,014	0,065	0,359	1,378	3,726	1
				-	-	-	-	-	
				0,027	0,128	0,654	2,361	11,999	2
				0,015	0,066	0,365	1,414	3,502	
				-	-	-	-	-	
				0,026	0,121	0,613	2,288	10,087	
				0,015	0,066	0,365	1,413	-	3
				0,025	0,076	0,590	2,196		

(1) 减速机级数
 (2) 传动比相关的数值可在 Tec Data Finder 中检索 - www.neugart.com
 (3) T_{min} = -40°C. 理想运行温度最高为 50°C
 (4) 距离减速机 1 m 时; 在输入转速为 n₁=3000 min⁻¹ 且无负荷时测得; i=5
 (5) 最大发动机重量* (单位: kg) = 0.2 × M_b / 发动机长度 (单位: m)
 * 发动机重量对称分布
 * 水平和固定的安装位置
 (6) 数据以 n₂=100 min⁻¹ 的输出轴转速为准。
 (7) 以输出轴中心为准
 (8) 更改 T_{2N}, F_r, F_a 以及周期和轴承使用寿命时, 数值存在偏差 (部分较高)。利用 NCP 针对应用进行专门设计 - www.neugart.com

(1) Number of stages
 (2) The ratio-dependent values can be retrieved in Tec Data Finder - www.neugart.com
 (3) T_{min} = -40°C. Optimal operating temperature max. 50°C
 (4) Sound pressure level from 1 m, measured on input running at n₁=3000 rpm no load; i=5
 (5) Max. motor weight* in kg = 0.2 × M_b / motor length in m
 * with symmetrically distributed motor weight
 * with horizontal and stationary mounting
 (6) These values are based on an output shaft speed of n₂=100 rpm
 (7) Based on center of output shaft
 (8) Other (sometimes higher) values following changes to T_{2N}, F_r, F_a, cycle, and service life of bearing. Application specific configuration with NCP - www.neugart.com

输出扭矩	Output torques			PLE040	PLE060	PLE080	PLE120	PLE160	i ⁽¹⁾	z ⁽²⁾
额定输出扭矩 ⁽³⁾⁽⁴⁾	Nominal output torque ⁽³⁾⁽⁴⁾	T _{2N}	Nm	11	28	85	115	400	3	1
				15	38	115	155	450	4	
				14	40	110	195	450	5	
				8,5	25	65	135	-	7	
				6	18	50	120	450	8	
				5	15	38	95	-	10	
				16,5	44	130	210	-	9	
				20	44	120	260	800	12	
				18	44	110	230	700	15	
				20	44	120	260	800	16	
				20	44	120	260	800	20	
				18	40	110	230	700	25	
				20	44	120	260	800	32	
				18	40	110	230	700	40	
				7,5	18	50	120	450	64	
				20	44	110	260	-	60	
				20	44	120	260	-	80	
				20	44	120	260	-	100	
				18	44	110	230	-	120	
				20	44	120	260	-	160	
				18	40	110	230	-	200	
				20	44	120	260	-	256	
				18	40	110	230	-	320	
				7,5	18	50	120	-	512	
最大输出扭矩 ⁽⁴⁾⁽⁵⁾	Max. output torque ⁽⁴⁾⁽⁵⁾	T _{2max}	Nm	17,5	45	136	184	640	3	1
				24	61	184	248	720	4	
				22	64	176	312	720	5	
				13,5	40	104	216	-	7	
				10	29	80	192	720	8	
				8	24	61	152	-	10	
				26	70	208	336	-	9	
				32	70	192	416	1280	12	
				29	70	176	368	1120	15	
				32	70	192	416	1280	16	
				32	70	192	416	1280	20	
				29	64	176	368	1120	25	
				32	70	192	416	1280	32	
				29	64	176	368	1120	40	
				12	29	80	192	720	64	
				32	70	176	416	-	60	
				32	70	192	416	-	80	
				32	70	192	416	-	100	
				29	70	176	368	-	120	
				32	70	192	416	-	160	
				29	64	176	368	-	200	
				32	70	192	416	-	256	
				29	64	176	368	-	320	
				12	29	80	192	-	512	

⁽¹⁾ 传动比 (i=n₁/n₂)

⁽²⁾ 减速机级数

⁽³⁾ 利用 NCP 针对应用进行专门设计 – www.neugart.com

⁽⁴⁾ 平键 (代码 „A”)时的数值: 针对交变载荷

⁽⁵⁾ 允许输出轴转动30,000转; 参见第 128 页

⁽¹⁾ Ratios (i=n₁/n₂)

⁽²⁾ Number of stages

⁽³⁾ Application specific configuration with NCP – www.neugart.com

⁽⁴⁾ Values for feather key (code "A"): for repeated load

⁽⁵⁾ 30,000 rotations of the output shaft permitted; see page 129

输出扭矩	Output torques			PLE040	PLE060	PLE080	PLE120	PLE160	i ⁽¹⁾	z ⁽²⁾
急停扭矩 ⁽³⁾	Emergency stop torque ⁽³⁾	T _{2Stop}	Nm	22,5	66	180	390	800	3	1
				30	88	240	520	900	4	
				36	80	220	500	900	5	
				26	80	178	340	-	7	
				27	80	190	380	900	8	
				27	80	200	480	-	10	
				33	88	260	500	-	9	2
				40	88	240	520	1600	12	
				36	88	220	500	1400	15	
				40	88	240	520	1600	16	
				40	88	240	520	1600	20	
				36	80	220	500	1400	25	
				40	88	240	520	1600	32	
				36	80	220	500	1400	40	
				27	80	190	380	900	64	
				40	88	220	520	-	60	
				40	88	240	520	-	80	
				40	88	240	520	-	100	
				36	88	220	500	-	120	
				40	88	240	520	-	160	
				36	80	220	500	-	200	
				40	88	240	520	-	256	
				36	80	220	500	-	320	
				27	80	190	380	-	512	

输入转速	Input speeds			PLE040	PLE060	PLE080	PLE120	PLE160	i ⁽¹⁾	z ⁽²⁾
T _{2N} 和 S1 时的平均热输入转速 ⁽⁴⁾⁽⁵⁾	Average thermal input speed at T _{2N} and S1 ⁽⁴⁾⁽⁵⁾	n _{1N}	min ⁻¹	5000	4500	4000 ⁽⁶⁾	3400 ⁽⁶⁾	1350 ⁽⁶⁾	3	1
				5000	4500	3900 ⁽⁶⁾	3500 ⁽⁶⁾	1450 ⁽⁶⁾	4	
				5000	4500	4000 ⁽⁶⁾	3500 ⁽⁶⁾	1700 ⁽⁶⁾	5	
				5000	4500	4000	3500	-	7	
				5000	4500	4000	3500	2200 ⁽⁶⁾	8	
				5000	4500	4000	3500	-	10	
				5000	4500	4000 ⁽⁶⁾	3500 ⁽⁶⁾	-	9	2
				5000	4500	4000 ⁽⁶⁾	3500 ⁽⁶⁾	1600 ⁽⁶⁾	12	
				5000	4500	4000	3500 ⁽⁶⁾	1900 ⁽⁶⁾	15	
				5000	4500	4000	3500 ⁽⁶⁾	1800 ⁽⁶⁾	16	
				5000	4500	4000	3500	2100 ⁽⁶⁾	20	
				5000	4500	4000	3500	2400 ⁽⁶⁾	25	
				5000	4500	4000	3500	2700 ⁽⁶⁾	32	
				5000	4500	4000	3500	3000 ⁽⁶⁾	40	
				5000	4500	4000	3500	3000	64	
				5000	4500	4000	3500	-	60	
				5000	4500	4000	3500	-	80	
				5000	4500	4000	3500	-	100	
				5000	4500	4000	3500	-	120	
				5000	4500	4000	3500	-	160	
				5000	4500	4000	3500	-	200	
				5000	4500	4000	3500	-	256	
				5000	4500	4000	3500	-	320	
				5000	4500	4000	3500	-	512	
5000	4500	4000	3500	-	512					
最高机械输入转速 ⁽⁴⁾	Max. mechanical input speed ⁽⁴⁾	n _{1Limit}	min ⁻¹	18000	13000	7000	6500	6500		1

(1) 传动比 (i=n₁/n₂)
 (2) 减速机级数
 (3) 允许 1000 次
 (4) 利用 NCP 针对应用设计转速- www.neugart.com
 (5) 定义请参见第 128 页
 (6) 在 50% T_{2N} 输出和 S1 模式下的平均热传动转速

(1) Ratios (i=n₁/n₂)
 (2) Number of stages
 (3) Permitted 1000 times
 (4) Application-specific speed configurations with NCP – www.neugart.com
 (5) See page 129 for the definition
 (6) Average thermal input speed at 50% T_{2N} and S1

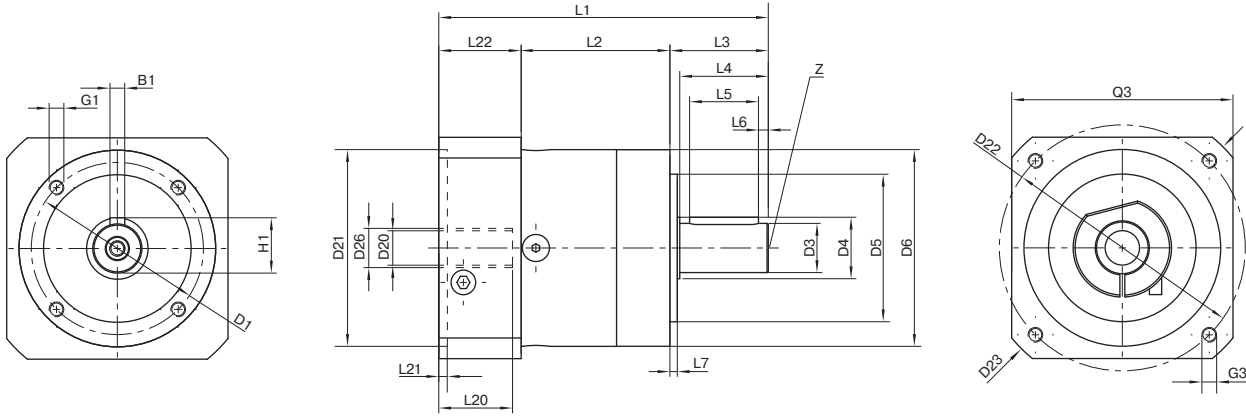

图示为带平键的 PLE060 / 1 级 / 附带平键的输出轴 / 11 mm 锁紧系统 / 适配电机法兰 - 单一法兰 / B5 电机法兰类型
 Drawing corresponds to a PLE060 / 1-stage / output shaft with feather key / 11 mm clamping system / motor adaptation - one part / B5 flange type motor
 所有其它变量可在 www.neugart.com 下 Tec Data Finder 中检索 - All other variants can be retrieved in the Tec Data Finder at www.neugart.com

几何尺寸 ⁽¹⁾	Geometry ⁽¹⁾			PLE040	PLE060	PLE080	PLE120	PLE160	z ⁽²⁾	Code
输出端安装孔节圆直径	Pitch circle diameter output	D1		34	52	70	100	145		
输出轴直径	Shaft diameter output	D3	h7	10	14	20	25	40		
输出轴轴肩直径	Shaft collar output	D4		12	17	25	35	55		
输出端定位凸台直径	Centering diameter output	D5	h7	26	40	60	80	130		
箱体直径	Housing diameter	D6		40	60	80	115	160		
安装螺纹 x 深度	Mounting thread x depth	G1	4x	M4x6	M5x8	M6x10	M10x16	M12x20		
最小总长	Min. total length	L1		88,5	106	133,5	176,5	255,5	1	
				101,5	118,5	150,5	204	305	2	
				114	131	168	231,5	-	3	
箱体长度	Housing length	L2		39	47	60	74	104	1	
				52	59,5	77,5	101,5	153,5	2	
				64,5	72	95	129	-	3	
输出轴轴长	Shaft length output	L3		26	35	40	55	87		
输出端定位凸台深度	Centering depth output	L7		2	3	3	4	5		
输入端锁紧系统直径	Clamping system diameter input	D26		更多信息见第 117 页 More information on page 117						
电机轴直径 j6/k6	Motor shaft diameter j6/k6	D20		具体尺寸视电机/减速机法兰而定。 可以在 www.neugart.com 下 Tec Data Finder. 中针对每个电机适配电机特有的输入法兰几何尺寸 The dimensions vary with the motor/gearbox flange. The input flange geometries can be retrieved for each specific motor in Tec Data Finder at www.neugart.com						
最大允许的电机轴长	Max. permis. motor shaft length	L20								
最小允许的电机轴长	Min. permis. motor shaft length									
输入端定位凹槽直径	Centering diameter input	D21								
输入端定位凹槽深度	Centering depth input	L21								
输入端安装孔节圆直径	Pitch circle diameter input	D22								
输入法兰长度	Motor flange length	L22								
输入法兰对角线尺寸	Diagonal dimension input	D23								
安装螺纹 x 深度	Mounting thread x depth	G3	4x							
输入端法兰外方	Flange cross section input	Q3	■							
附带平键的输出轴 (DIN 6885-1)	Output shaft with feather key (DIN 6885-1)			A 3x3x18	A 5x5x25	A 6x6x28	A 8x7x40	A 12x8x65		A
平键宽度 (DIN 6885-1)	Feather key width (DIN 6885-1)	B1		3	5	6	8	12		
含平键在内的轴高 (DIN 6885-1)	Shaft height including feather key (DIN 6885-1)	H1		11,2	16	22,5	28	43		
到轴肩的距离	Shaft length from shoulder	L4		23	30	36	50	80		
平键长度	Feather key length	L5		18	25	28	40	65		
到轴端的距离	Distance from shaft end	L6		2,5	2,5	4	5	8		
中心孔 (DIN 332, DR 形)	Center hole (DIN 332, type DR)	Z		M3x9	M5x12,5	M6x16	M10x22	M16x36		
光滑输出轴	Smooth output shaft									B
到轴肩的距离	Shaft length from shoulder	L4		23	30	36	50	80		

⁽¹⁾ 所有的尺寸单位为mm
⁽²⁾ 减速机级数

⁽¹⁾ Dimensions in mm
⁽²⁾ Number of stages

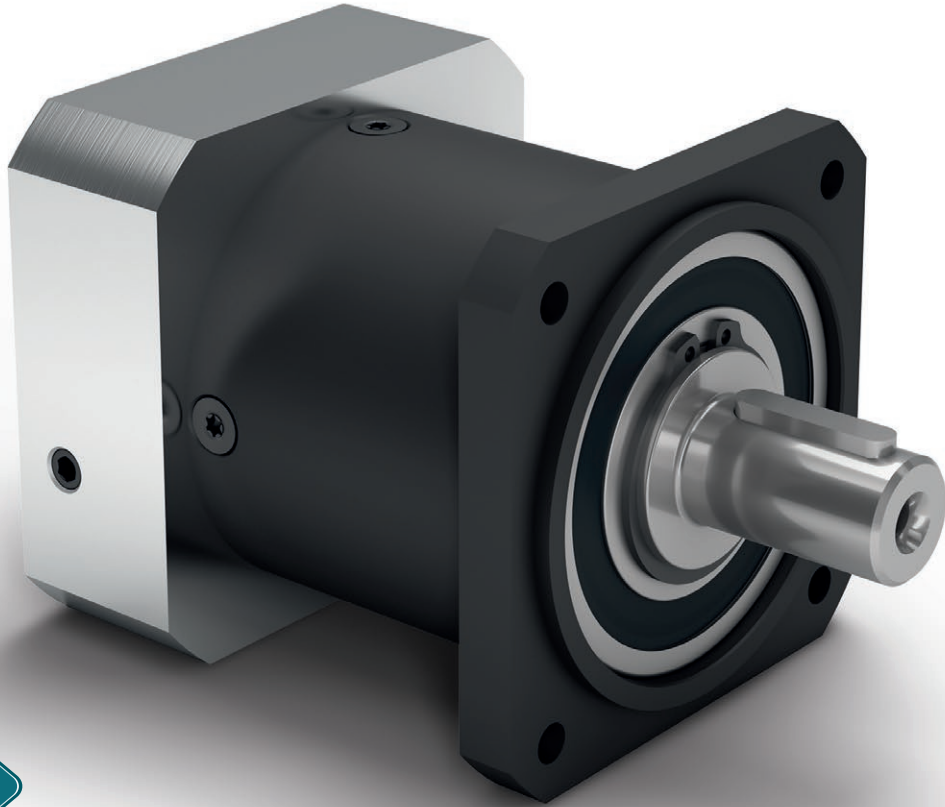

PLQE

一款可便捷安装的行星减速机。 发热量低 可承受较高的力

这款 **PLQE** 结构简单，功能强劲。无需中间法兰便可直接将其连接在设备上。从动机构上较大规格的深沟球轴承能够承受较高的径向力和轴向力。同时仅产生极低的热量，即使在要求极高的生产循环中也能安全可靠地运行。

- + 可安装在任意位置
- + 输入法兰可适配特殊的电机
- + 终生润滑，因此免维护
- + 旋转方向同向
- + 输出轴样式多样
- + 优化转动惯量的锁紧系统
- + 精确啮合

The easy to install planetary gearbox absorbs high forces with low heat generation

Our **PLQE** is uncomplicated and powerful. It can be connected directly to your installation without the need for an intermediate flange. The large deep groove ball bearings at the output can absorb large axial and radial forces. In the process, only little heat is generated, so reliable operations are assured even in complex production cycles.

- + For any mounting position
- + Individual adaptation of the input flange to the motor
- + Lifetime lubrication for maintenance-free operation
- + Equidirectional rotation
- + Wide range of output shaft designs
- + Clamping systems with optimized mass moment of inertia
- + Precise gearing

② 安装简便

PLQE 配有带通孔的正方形输出法兰，因此可以直接将其安装在设备上，这样可以节省时间和成本。安装时，可通过通孔从任意角度对其进行安装。由此一来，进行结构设计就会变得十分简便。

① 经过优化的输出轴承

较大规格的深沟球轴承使得 **PLQE** 的性能尤其强劲。它能够承受较高的轴向力和径向力。无需额外的轴承组件，其驱动元件可直接安装在输出轴上。

③ 最高转速时发热量仍很低

Neugart 研发的低摩擦损耗轴承结构和经过优化的润滑功能使得：**PLQE** 即使在面临极端挑战时也能自如应对。

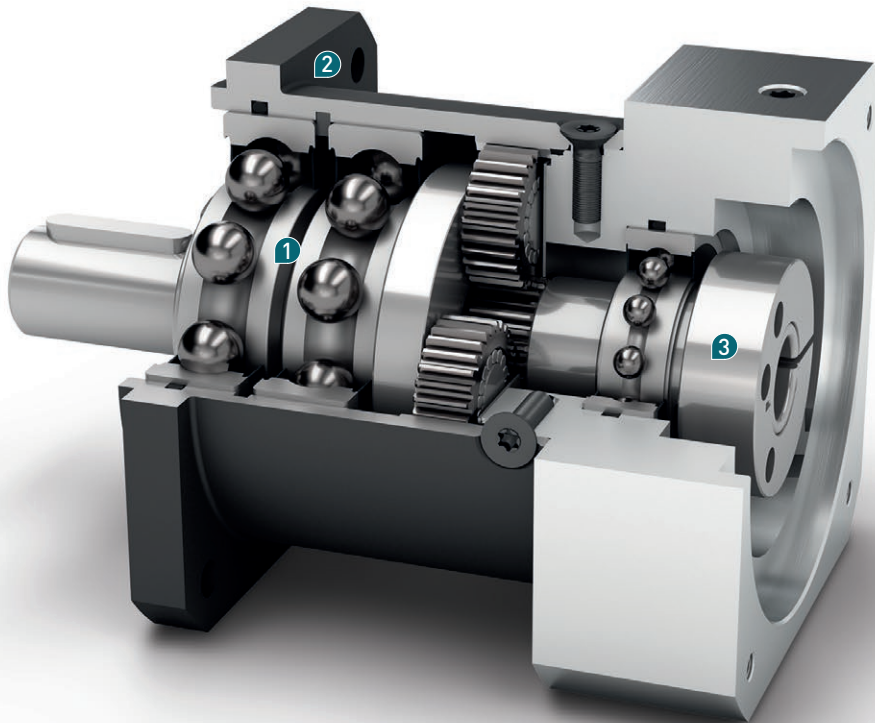

① Optimized output bearing

Large deep groove ball bearings make the **PLQE** especially powerful. It can even absorb high axial and radial forces with ease. Your drive elements can therefore be installed directly on the output shaft without the need for additional bearing components.

② Easy installation

The square output flange on the **PLQE** with through hole can be mounted directly on the installation – saving time and money. These through holes facilitate full accessibility during installation. This makes your engineering much easier.

③ Low heat generation at the highest speeds

A Neugart developed low-friction bearing design and optimized lubrication make it possible: The **PLQE** overcomes extreme challenges.

Code	减速机参数	Gearbox characteristics			PLQE060	PLQE080	PLQE120	z ⁽¹⁾
	使用寿命	Service life	t _L	h	30.000			
	满载时效率 ⁽²⁾	Efficiency at full load ⁽²⁾	η	%	98			1
97					2			
92					3			
	最低工作温度	Min. operating temperature	T _{min}	°C	-25			
	最高工作温度	Max. operating temperature	T _{max}		90			
	防护等级	Protection class			IP 54			
S	标准润滑	Standard lubrication			润滑脂 / Grease			
F	食品级润滑	Food grade lubrication			润滑脂 / Grease			
L	低温润滑 ⁽³⁾	Low temperature lubrication ⁽³⁾			润滑脂 / Grease			
	安装位置	Installation position			任意 / Any			
S	标准回程间隙	Standard backlash	j _t	arcmin	< 10	< 7	< 7	1
					< 12	< 9	< 9	2
					< 15	< 11	< 11	3
	抗扭刚度 ⁽²⁾	Torsional stiffness ⁽²⁾	c _g	Nm / arcmin	1,8 - 2,4	5,2 - 7,0	11,3 - 15,2	1
					1,9 - 2,4	5,7 - 7,0	12,3 - 15,2	2
					1,8 - 2,4	5,4 - 7,0	11,7 - 15,2	3
	减速机重量	Gearbox weight	m _G	kg	1,1	3,2	6,6	1
					1,3	3,7	8,6	2
					1,5	4,2	10,6	3
S	标准的箱体表面	Standard surface			箱体: 钢 - 氮碳共渗和后氧化处理 (黑色) Housing: Steel - nitrocarburized and post-oxidized (black)			
	运行噪音 ⁽⁴⁾	Running noise ⁽⁴⁾	Q _g	dB(A)	58	60	65	
	基于减速机输入法兰的最大弯矩 ⁽⁵⁾	Max. bending moment based on the gearbox input flange ⁽⁵⁾	M _b	Nm	8	16	40	
	电机法兰精度	Motor flange precision			DIN 42955-N			

输出轴载荷	Output shaft loads			PLQE060	PLQE080	PLQE120	z ⁽¹⁾
20,000 h 的径向力 ⁽⁶⁾⁽⁷⁾	Radial force for 20,000 h ⁽⁶⁾⁽⁷⁾	F _{r20.000h}	N	900	2050	2950	
20,000 h 的轴向力 ⁽⁶⁾⁽⁷⁾	Axial force for 20,000 h ⁽⁶⁾⁽⁷⁾	F _{a20.000h}		1000	2500	2500	
30,000 h 的径向力 ⁽⁶⁾⁽⁷⁾	Radial force for 30,000 h ⁽⁶⁾⁽⁷⁾	F _{r30.000h}		700	1700	2400	
30,000 h 的轴向力 ⁽⁶⁾⁽⁷⁾	Axial force for 30,000 h ⁽⁶⁾⁽⁷⁾	F _{a30.000h}		800	2000	2100	
静态径向力 ⁽⁷⁾⁽⁸⁾	Static radial force ⁽⁷⁾⁽⁸⁾	F _{r Stat}		1500	2500	4000	
静态轴向力 ⁽⁷⁾⁽⁸⁾	Static axial force ⁽⁷⁾⁽⁸⁾	F _{a Stat}		1950	3800	3800	
20,000 h 倾斜力矩 ⁽⁶⁾⁽⁸⁾	Tilting moment for 20,000 h ⁽⁶⁾⁽⁸⁾	M _{K20.000h}	Nm	37	101	232	
30,000 h 倾斜力矩 ⁽⁶⁾⁽⁸⁾	Tilting moment for 30,000 h ⁽⁶⁾⁽⁸⁾	M _{K30.000h}		29	84	188	

转动惯量	Moment of inertia			PLQE060	PLQE080	PLQE120	z ⁽¹⁾
转动惯量 ⁽²⁾	Mass moment of inertia ⁽²⁾	J	kgcm ²	0,066 - 0,142	0,371 - 0,783	1,381 - 2,393	1
				0,066 - 0,123	0,366 - 0,625	1,414 - 2,292	2
				0,066 - 0,076	0,365 - 0,590	1,413 - 2,196	3

(1) 减速机级数

(2) 传动比相关的数值可在 Tec Data Finder 中检索 - www.neugart.com

(3) T_{min} = -40°C. 理想运行温度最高为 50°C

(4) 距离减速机 1 m 时; 在输入转速为 n₁=3000 min⁻¹ 且无负荷时测得; i=5

(5) 最大发动机重量* (单位: kg) = 0.2 × M_b / 发动机长度 (单位: m)

* 发动机重量对称分布

* 水平和固定的安装位置

(6) 数据以 n₂=100 min⁻¹ 的输出轴转速为准。

(7) 以输出轴中心为准

(8) 更改 T_{2N}, F_r, F_a 以及周期和轴承使用寿命时, 数值存在偏差 (部分较高)。利用 NCP 针对应用进行专门设计 - www.neugart.com

(1) Number of stages

(2) The ratio-dependent values can be retrieved in Tec Data Finder - www.neugart.com

(3) T_{min} = -40°C. Optimal operating temperature max. 50°C

(4) Sound pressure level from 1 m, measured on input running at n₁=3000 rpm no load; i=5

(5) Max. motor weight* in kg = 0.2 × M_b / motor length in m

* with symmetrically distributed motor weight

* with horizontal and stationary mounting

(6) These values are based on an output shaft speed of n₂=100 rpm

(7) Based on center of output shaft

(8) Other (sometimes higher) values following changes to T_{2N}, F_r, F_a, cycle, and service life of bearing. Application specific configuration with NCP - www.neugart.com

输出扭矩	Output torques			PLQE060	PLQE080	PLQE120	i ⁽¹⁾	z ⁽²⁾				
额定输出扭矩 ⁽³⁾⁽⁴⁾	Nominal output torque ⁽³⁾⁽⁴⁾	T _{2N}	Nm	28	85	115	3	1				
				38	115	155	4					
				40	110	195	5					
				25	65	135	7					
				18	50	120	8					
				15	38	95	10					
				44	130	210	9	2				
				44	120	260	12					
				44	110	230	15					
				44	120	260	16					
				44	120	260	20					
				40	110	230	25					
				44	120	260	32	3				
				40	110	230	40					
				18	50	120	64					
				44	110	260	60					
				44	120	260	80					
				44	120	260	100					
				44	110	230	120	3				
				44	120	260	160					
				40	110	230	200					
				44	120	260	256					
				40	110	230	320					
				18	50	120	512					
				最大输出扭矩 ⁽⁴⁾⁽⁵⁾	Max. output torque ⁽⁴⁾⁽⁵⁾	T _{2max}	Nm	45	136	184	3	1
								61	184	248	4	
								64	176	312	5	
40	104	216	7									
29	80	192	8									
24	61	152	10									
70	208	336	9					2				
70	192	416	12									
70	176	368	15									
70	192	416	16									
70	192	416	20									
64	176	368	25									
70	192	416	32					3				
64	176	368	40									
29	80	192	64									
70	176	416	60									
70	192	416	80									
70	192	416	100									
70	176	368	120					3				
70	192	416	160									
64	176	368	200									
70	192	416	256									
64	176	368	320									
29	80	192	512									

PLQE

⁽¹⁾ 传动比 (i=n₁/n₂)

⁽²⁾ 减速机级数

⁽³⁾ 利用 NCP 针对应用进行专门设计 – www.neugart.com

⁽⁴⁾ 平键 (代码 „A”)时的数值: 针对交变载荷

⁽⁵⁾ 允许输出轴转动30,000转; 参见第 128 页

⁽¹⁾ Ratios (i=n₁/n₂)

⁽²⁾ Number of stages

⁽³⁾ Application specific configuration with NCP – www.neugart.com

⁽⁴⁾ Values for feather key (code "A"): for repeated load

⁽⁵⁾ 30,000 rotations of the output shaft permitted; see page 129

输出扭矩	Output torques			PLQE060	PLQE080	PLQE120	i ⁽¹⁾	z ⁽²⁾
急停扭矩 ⁽³⁾	Emergency stop torque ⁽³⁾	T _{2Stop}	Nm	66	180	390	3	1
				88	240	520	4	
				80	220	500	5	
				80	178	340	7	
				80	190	380	8	
				80	200	480	10	
				88	260	500	9	2
				88	240	520	12	
				88	220	500	15	
				88	240	520	16	
				88	240	520	20	
				80	220	500	25	
				88	240	520	32	3
				80	220	500	40	
				80	190	380	64	
				88	220	520	60	
				88	240	520	80	
				88	240	520	100	
				88	220	500	120	3
				88	240	520	160	
				80	220	500	200	
				88	240	520	256	
				80	220	500	320	
				80	190	380	512	

输入转速	Input speeds			PLQE060	PLQE080	PLQE120	i ⁽¹⁾	z ⁽²⁾
T _{2N} 和 S1 时的平均热输入转速 ⁽⁴⁾⁽⁵⁾	Average thermal input speed at T _{2N} and S1 ⁽⁴⁾⁽⁵⁾	n _{1N}	min ⁻¹	4500 ⁽⁶⁾	3400 ⁽⁶⁾	3400 ⁽⁶⁾	3	1
				4500 ⁽⁶⁾	3450 ⁽⁶⁾	3500 ⁽⁶⁾	4	
				4500	4000 ⁽⁶⁾	3500 ⁽⁶⁾	5	
				4500	4000	3500	7	
				4500	4000	3500	8	
				4500	4000	3500	10	
				4500	4000 ⁽⁶⁾	3500 ⁽⁶⁾	9	2
				4500	4000 ⁽⁶⁾	3500 ⁽⁶⁾	12	
				4500	4000	3500 ⁽⁶⁾	15	
				4500	4000	3500 ⁽⁶⁾	16	
				4500	4000	3500	20	
				4500	4000	3500	25	
				4500	4000	3500	32	3
				4500	4000	3500	40	
				4500	4000	3500	64	
				4500	4000	3500	60	
				4500	4000	3500	80	
				4500	4000	3500	100	
				4500	4000	3500	120	3
				4500	4000	3500	160	
				4500	4000	3500	200	
				4500	4000	3500	256	
				4500	4000	3500	320	
				4500	4000	3500	512	
最高机械输入转速 ⁽⁴⁾	Max. mechanical input speed ⁽⁴⁾	n _{1Limit}	min ⁻¹	13000	7000	6500		

(1) 传动比 (i=n₁/n₂)

(2) 减速机级数

(3) 允许 1000 次

(4) 利用 NCP 针对应用设计转速 - www.neugart.com

(5) 定义请参见第 128 页

(6) 在 50% T_{2N} 输出和 S1 模式下的平均热传动转速

(1) Ratios (i=n₁/n₂)

(2) Number of stages

(3) Permitted 1000 times

(4) Application-specific speed configurations with NCP - www.neugart.com

(5) See page 129 for the definition

(6) Average thermal input speed at 50% T_{2N} and S1

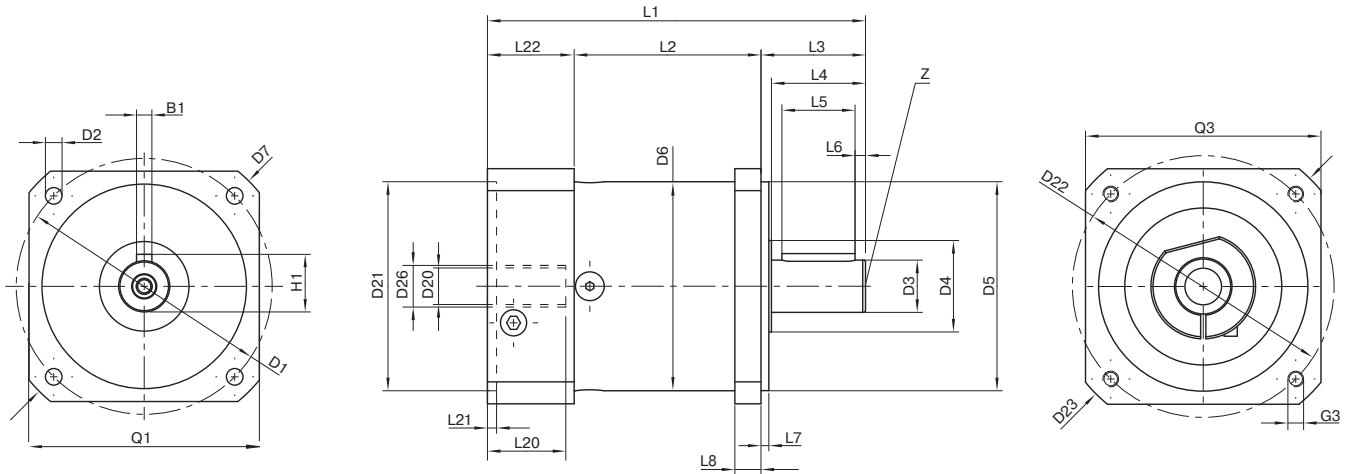

图示为带平键的 PLQE080 / 1 级 / 附带平键的输出轴 / 19 mm 锁紧系统 / 适配电机法兰 - 单一法兰 / B5 电机法兰类型
 Drawing corresponds to a PLQE080 / 1-stage / output shaft with feather key / 19 mm clamping system / motor adaptation - one part / B5 flange type motor
 所有其它变量可在 www.neugart.com 下 Tec Data Finder 中检索 - All other variants can be retrieved in the Tec Data Finder at www.neugart.com

几何尺寸 ⁽¹⁾	Geometry ⁽¹⁾			PLQE060	PLQE080	PLQE120	z ⁽²⁾	Code	
输出端安装孔节圆直径	Pitch circle diameter output	D1		75	100	130			
输出端安装孔直径	Mounting bore output	D2	4x	5,5	6,5	8,5			
输出轴直径	Shaft diameter output	D3	h7	16	20	25			
输出轴轴肩直径	Shaft collar output	D4		20	35	35			
输出端定位凸台直径	Centering diameter output	D5	h7	60	80	110			
箱体直径	Housing diameter	D6		60	80	115			
输出法兰对角线尺寸	Diagonal dimension output	D7		92	116	145			
输出端法兰外方	Flange cross section output	Q1	■	70	90	115			
最小总长	Min. total length	L1		111	145	201,5	1		
				123,5	162,5	229,5	2		
				136	180	257	3		
箱体长度	Housing length	L2		55	71,5	99	1		
				67,5	89	127	2		
				80	106,5	154,5	3		
输出轴轴长	Shaft length output	L3		32	40	55			
输出端定位凸台深度	Centering depth output	L7		3	3	4			
输出端法兰厚度	Flange thickness output	L8		10	10	15			
输入端锁紧系统直径	Clamping system diameter input	D26		更多信息见第 117 页 More information on page 117					
电机轴直径 j6/k6	Motor shaft diameter j6/k6	D20		具体尺寸视电机/减速机法兰而定。 可以在 www.neugart.com 下 Tec Data Finder 中针对每个电机适配电机特有的输入法兰几何尺寸 The dimensions vary with the motor/gearbox flange. The input flange geometries can be retrieved for each specific motor in Tec Data Finder at www.neugart.com					
最大允许的电机轴长	Max. permis. motor shaft length	L20							
最小允许的电机轴长	Min. permis. motor shaft length								
输入端定位凹槽直径	Centering diameter input	D21							
输入端定位凹槽深度	Centering depth input	L21							
输入端安装孔节圆直径	Pitch circle diameter input	D22							
输入法兰长度	Motor flange length	L22							
输入法兰对角线尺寸	Diagonal dimension input	D23							
安装螺纹 x 深度	Mounting thread x depth	G3	4x						
输入端法兰外方	Flange cross section input	Q3	■						
附带平键的输出轴 (DIN 6885-1)	Output shaft with feather key (DIN 6885-1)			A 5x5x20	A 6x6x28	A 8x7x40		A	
平键宽度 (DIN 6885-1)	Feather key width (DIN 6885-1)	B1		5	6	8			
含平键在内的轴高 (DIN 6885-1)	Shaft height including feather key (DIN 6885-1)	H1		18	22,5	28			
到轴肩的距离	Shaft length from shoulder	L4		28	36	50			
平键长度	Feather key length	L5		20	28	40			
到轴端的距离	Distance from shaft end	L6		4	4	5			
中心孔 (DIN 332 DR 形)	Center hole (DIN 332, type DR)	Z		M5x12,5	M6x16	M10x22			
光滑输出轴	Smooth output shaft							B	
到轴肩的距离	Shaft length from shoulder	L4		28	36	50			

⁽¹⁾ 所有的尺寸单位为mm
⁽²⁾ 减速机级数

⁽¹⁾ Dimensions in mm
⁽²⁾ Number of stages

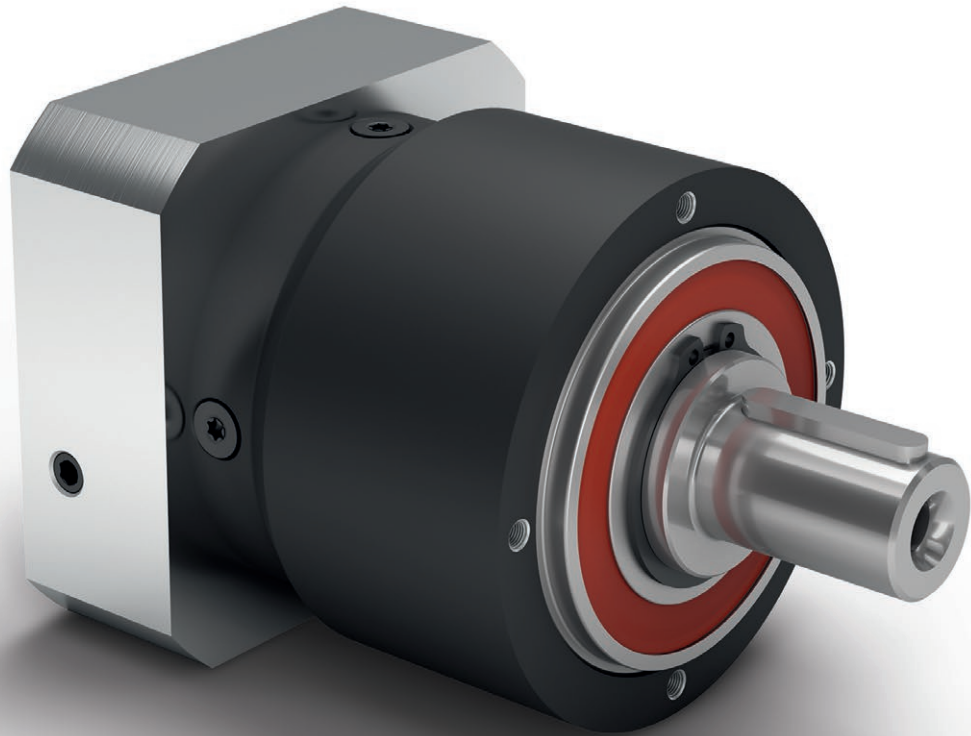

PLPE

经济型行星减速机 发热量低

PLPE 集合了经济型产品系列的最佳特性，同时在性能上又有所提升：它经济实用，但同时又性能强劲，而且产生的热量也极少。其经过优化的输出轴承适用于径向力和轴向力较高的应用情况。

The cost effective planetary gearbox with the best torque-low heat performance

Our PLPE unites the best properties of the Economy Line with a performance advantage. It is cost effective, yet powerful, and generates minimal heat. The optimized output bearing has been designed for high radial and axial forces.

- + 可安装在任意位置
- + 输入法兰可适配特殊的电机
- + 终生润滑，因此免维护
- + 旋转方向同向
- + 输出轴样式多样
- + 优化转动惯量的锁紧系统
- + 精确啮合

- + For any mounting position
- + Individual adaptation of the input flange to the motor
- + Lifetime lubrication for maintenance-free operation
- + Equidirectional rotation
- + Wide range of output shaft designs
- + Clamping systems with optimized mass moment of inertia
- + Precise gearing

1 较高的轴向力和径向力

PLPE 配有较大规格的深沟球轴承能够承受较高的径向力和轴向力。无需额外的轴承组件，其驱动元件可直接安装在输出轴上。这使得该减速机的结构十分简单且灵活。

2 在价格方面有着无可比拟的优势

PLPE 是我们在经济型产品系列中的明星产品之一。此款行星减速机性能良好，节能表现极其出众。而且价格十分合理。

3 最高转速时放热量仍很低

其低摩擦损耗轴承设计和经过优化的润滑功能使得 PLPE 十分耐用。由于产生的热量极低，因此在采用了最高标准的测试中其仍然表现不俗。

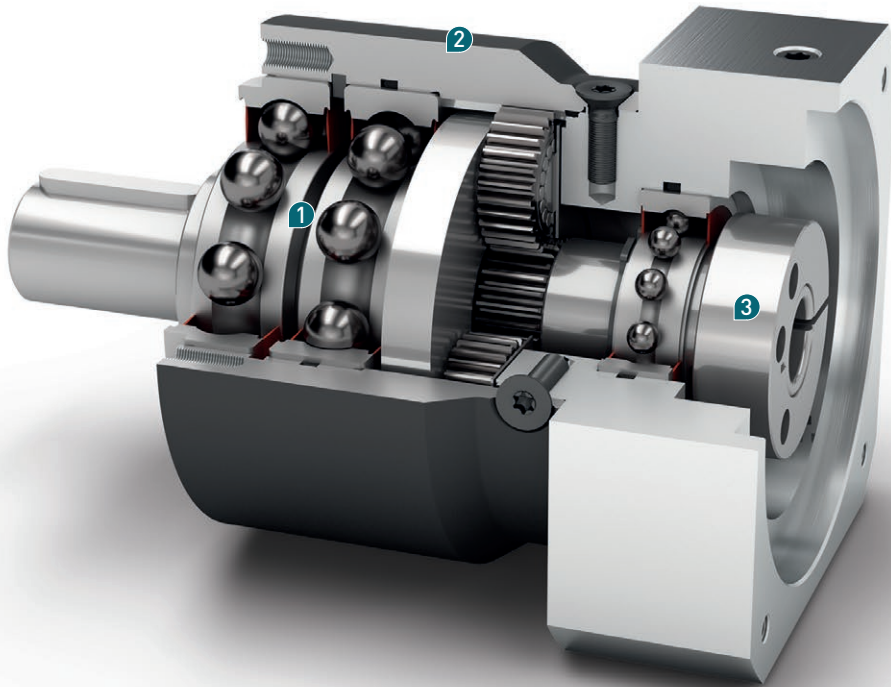

1 High axial and radial forces

The large deep groove ball bearings in the PLPE can absorb large radial and axial forces. Your drive elements can therefore be installed directly on the output shaft without the need for additional bearing components. This makes it easy to use and flexible.

2 Best price

The PLPE is one of the pillars of our Economy Line. You are given a powerful planetary gearbox with very high energy efficiency – and that at a particularly fair price.

3 Low heat generation at the highest speeds

Its low-friction bearing design and optimized lubrication make the PLPE extremely resistant. And thanks to its low heat generation, it also passes the most demanding tests.

Code	减速机参数	Gearbox characteristics			PLPE050	PLPE070	PLPE090	PLPE120	PLPE155	z ⁽¹⁾
	使用寿命	Service life	t _L	h	30.000					
	满载时效率 ⁽²⁾	Efficiency at full load ⁽²⁾	η	%	98					1
					97					2
	最低工作温度	Min. operating temperature	T _{min}	°C	-25					
	最高工作温度	Max. operating temperature	T _{max}		90					
	防护等级	Protection class			IP 54					
S	标准润滑	Standard lubrication			润滑脂 / Grease					
F	食品级润滑	Food grade lubrication			润滑脂 / Grease					
L	低温润滑 ⁽³⁾	Low temperature lubrication ⁽³⁾			润滑脂 / Grease					
	安装位置	Installation position			任意 / Any					
S	标准回程间隙	Standard backlash	j _t	arcmin	< 15	< 10	< 7	< 7	< 8	1
					< 19	< 12	< 9	< 9	< 10	2
	抗扭刚度 ⁽²⁾	Torsional stiffness ⁽²⁾	c _G	Nm / arcmin	0,8 - 1,1	2,6 - 3,5	7,3 - 9,8	20,0 - 27,0	38,5 - 52,0	1
					0,8 - 1,1	2,7 - 3,5	7,4 - 9,8	20,5 - 27,0	39,5 - 52,0	2
	减速机重量	Gearbox weight	m _G	kg	0,7	1,5	3	7,5	16,5	1
					0,9	1,8	3,7	9,7	20,5	2
S	标准的箱体表面	Standard surface			箱体: 钢 - 氮碳共渗和后氧化处理 (黑色) Housing: Steel - nitrocarburized and post-oxidized (black)					
	运行噪音 ⁽⁴⁾	Running noise ⁽⁴⁾	Q _G	dB(A)	58	58	60	65	70	
	基于减速机输入法兰的最大弯矩 ⁽⁵⁾	Max. bending moment based on the gearbox input flange ⁽⁵⁾	M _b	Nm	3	8	16	40	180	
	电机法兰精度	Motor flange precision			DIN 42955-N					

输出轴载荷	Output shaft loads			PLPE050	PLPE070	PLPE090	PLPE120	PLPE155	z ⁽¹⁾
20,000 h 的径向力 ⁽⁶⁾⁽⁷⁾	Radial force for 20,000 h ⁽⁶⁾⁽⁷⁾	F _{r20.000h}	N	800	1050	1900	2500	5200	
20,000 h 的轴向力 ⁽⁶⁾⁽⁷⁾	Axial force for 20,000 h ⁽⁶⁾⁽⁷⁾	F _{a20.000h}		1000	1350	2000	4000	7000	
30,000 h 的径向力 ⁽⁶⁾⁽⁷⁾	Radial force for 30,000 h ⁽⁶⁾⁽⁷⁾	F _{r30.000h}		700	900	1700	2150	4600	
30,000 h 的轴向力 ⁽⁶⁾⁽⁷⁾	Axial force for 30,000 h ⁽⁶⁾⁽⁷⁾	F _{a30.000h}		800	1000	1500	3000	6000	
静态径向力 ⁽⁷⁾⁽⁸⁾	Static radial force ⁽⁷⁾⁽⁸⁾	F _{r Stat}		1300	1650	3100	4000	8400	
静态轴向力 ⁽⁷⁾⁽⁸⁾	Static axial force ⁽⁷⁾⁽⁸⁾	F _{a Stat}		1000	2100	3800	5900	11000	
20,000 h 倾斜力矩 ⁽⁶⁾⁽⁸⁾	Tilting moment for 20,000 h ⁽⁶⁾⁽⁸⁾	M _{K20.000h}	Nm	26	42	99	168	497	
30,000 h 倾斜力矩 ⁽⁶⁾⁽⁸⁾	Tilting moment for 30,000 h ⁽⁶⁾⁽⁸⁾	M _{K30.000h}		22	36	89	144	440	

转动惯量	Moment of inertia			PLPE050	PLPE070	PLPE090	PLPE120	PLPE155	z ⁽¹⁾
转动惯量 ⁽²⁾	Mass moment of inertia ⁽²⁾	J	kgcm ²	0,015	0,069	0,374	1,419	4,932	1
				-	-	-	-	-	
				0,030	0,174	0,789	2,764	7,611	2
				0,014	0,064	0,356	1,376	4,759	
				-	-	-	-	-	
				0,026	0,126	0,625	2,334	7,108	

(1) 减速机级数
 (2) 传动比相关的数值可在 Tec Data Finder 中检索 - www.neugart.com
 (3) T_{min} = -40°C. 理想运行温度最高为 50°C
 (4) 距离减速机 1 m 时; 在输入转速为 n₁=3000 min⁻¹ 且无负荷时测得; i=5
 (5) 最大发动机重量* (单位: kg) = 0.2 × M_b / 发动机长度 (单位: m)
 * 发动机重量对称分布
 * 水平和固定的安装位置
 (6) 数据以 n₂=100 min⁻¹ 的输出轴转速为准。
 (7) 以输出轴中心为准
 (8) 更改 T_{2N}, F_r, F_a 以及周期和轴承使用寿命时, 数值存在偏差 (部分较高)。利用 NCP 针对应用进行专门设计 - www.neugart.com

(1) Number of stages
 (2) The ratio-dependent values can be retrieved in Tec Data Finder - www.neugart.com
 (3) T_{min} = -40°C. Optimal operating temperature max. 50°C
 (4) Sound pressure level from 1 m, measured on input running at n₁=3000 rpm no load; i=5
 (5) Max. motor weight* in kg = 0.2 × M_b / motor length in m
 * with symmetrically distributed motor weight
 * with horizontal and stationary mounting
 (6) These values are based on an output shaft speed of n₂=100 rpm
 (7) Based on center of output shaft
 (8) Other (sometimes higher) values following changes to T_{2N}, F_r, F_a, cycle, and service life of bearing. Application specific configuration with NCP - www.neugart.com

输出扭矩	Output torques			PLPE050	PLPE070	PLPE090	PLPE120	PLPE155	i ⁽¹⁾	z ⁽²⁾
额定输出扭矩 ⁽³⁾⁽⁴⁾	Nominal output torque ⁽³⁾⁽⁴⁾	T _{2N}	Nm	11	28	85	115	-	3	1
				15	33	90	155	460	4	
				13	30	82	172	445	5	
				8,5	25	65	135	-	7	
				6	18	50	120	-	8	
				5	15	38	95	210	10	
				12	33	97	157	-	9	
				15	33	90	195	-	12	
				13	33	82	172	-	15	
				15	33	90	195	460	16	
				15	33	90	195	460	20	
				13	30	82	172	445	25	
				15	33	90	195	-	32	
				13	30	82	172	460	40	
				-	-	-	-	445	50	
				7,5	18	50	120	-	64	
5	15	38	95	210	100					
最大输出扭矩 ⁽⁴⁾⁽⁵⁾	Max. output torque ⁽⁴⁾⁽⁵⁾	T _{2max}	Nm	17,5	45	136	184	-	3	1
				24	53	144	248	736	4	
				21	48	131	275	712	5	
				13,5	40	104	216	-	7	
				9,5	29	80	192	-	8	
				8	24	61	152	336	10	
				19	53	155	251	-	9	
				24	53	144	312	-	12	
				21	53	131	275	-	15	
				24	53	144	312	736	16	
				24	53	144	312	736	20	
				21	48	131	275	712	25	
				24	53	144	312	-	32	
				21	48	131	275	736	40	
				-	-	-	-	712	50	
				12	29	80	192	-	64	
8	24	61	152	336	100					

PLPE

⁽¹⁾ 传动比 (i=n₁/n₂)

⁽²⁾ 减速机级数

⁽³⁾ 利用 NCP 针对应用进行专门设计 – www.neugart.com

⁽⁴⁾ 平键 (代码 „A”)时的数值: 针对交变载荷

⁽⁵⁾ 允许输出轴转动30.000转; 参见第 128 页

⁽¹⁾ Ratios (i=n₁/n₂)

⁽²⁾ Number of stages

⁽³⁾ Application specific configuration with NCP – www.neugart.com

⁽⁴⁾ Values for feather key (code “A”): for repeated load

⁽⁵⁾ 30,000 rotations of the output shaft permitted; see page 129

输出扭矩	Output torques			PLPE050	PLPE070	PLPE090	PLPE120	PLPE155	i ⁽¹⁾	z ⁽²⁾
急停扭矩 ⁽³⁾	Emergency stop torque ⁽³⁾	T _{2stop}	Nm	22,5	66	180	390	-	3	1
				30	88	240	520	920	4	
				36	80	220	500	890	5	
				26	80	178	340	-	7	
				27	80	190	380	-	8	
				27	80	200	480	420	10	
				33	88	260	500	-	9	2
				40	88	240	520	-	12	
				36	88	220	500	-	15	
				40	88	240	520	920	16	
				40	88	240	520	920	20	
				36	80	220	500	890	25	
				40	88	240	520	-	32	
				36	80	220	500	920	40	
				-	-	-	-	890	50	
				27	80	190	380	-	64	
				27	80	200	480	420	100	

输入转速	Input speeds			PLPE050	PLPE070	PLPE090	PLPE120	PLPE155	i ⁽¹⁾	z ⁽²⁾
T _{2N} 和 S1 时的平均热输入转速 ⁽⁴⁾⁽⁵⁾	Average thermal input speed at T _{2N} and S1 ⁽⁴⁾⁽⁵⁾	n _{1N}	min ⁻¹	5000	4500 ⁽⁶⁾	3250 ⁽⁶⁾	2650 ⁽⁶⁾	-	3	1
				5000	4500 ⁽⁶⁾	3750 ⁽⁶⁾	2800 ⁽⁶⁾	1800 ⁽⁶⁾	4	
				5000	4500	4000 ⁽⁶⁾	3100 ⁽⁶⁾	2150 ⁽⁶⁾	5	
				5000	4500	4000	3500 ⁽⁶⁾	-	7	
				5000	4500	4000	3500	-	8	
				5000	4500	4000	3500	3000	10	
				5000	4500	4000 ⁽⁶⁾	3500 ⁽⁶⁾	-	9	2
				5000	4500	4000	3500 ⁽⁶⁾	-	12	
				5000	4500	4000	3500 ⁽⁶⁾	-	15	
				5000	4500	4000	3500 ⁽⁶⁾	2900 ⁽⁶⁾	16	
				5000	4500	4000	3500	3000 ⁽⁶⁾	20	
				5000	4500	4000	3500	3000 ⁽⁶⁾	25	
				5000	4500	4000	3500	-	32	
				5000	4500	4000	3500	3000	40	
				-	-	-	-	3000	50	
				5000	4500	4000	3500	-	64	
				5000	4500	4000	3500	3000	100	
				最高机械输入转速 ⁽⁴⁾	Max. mechanical input speed ⁽⁴⁾	n _{1Limit}	min ⁻¹	18000	13000	

⁽¹⁾ 传动比 (i=n₁/n₂)

⁽²⁾ 减速机级数

⁽³⁾ 允许 1000 次

⁽⁴⁾ 利用 NCP 针对应用设计转速 - www.neugart.com

⁽⁵⁾ 定义请参见第 128 页

⁽⁶⁾ 在 50% T_{2N} 输出和 S1 模式下的平均热传动转速

⁽¹⁾ Ratios (i=n₁/n₂)

⁽²⁾ Number of stages

⁽³⁾ Permitted 1000 times

⁽⁴⁾ Application-specific speed configurations with NCP - www.neugart.com

⁽⁵⁾ See page 129 for the definition

⁽⁶⁾ Average thermal input speed at 50% T_{2N} and S1

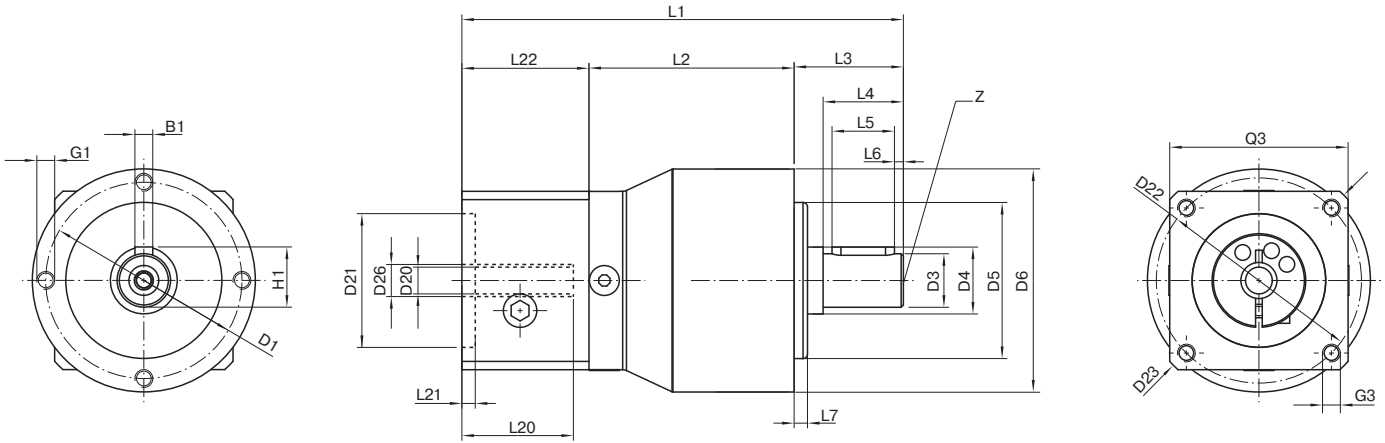

图示为带平键的 PLPE050 / 1 级 / 附带平键的输出轴 / 8 mm 锁紧系统 / 适配电机法兰 - 单一法兰 / B5 电机法兰类型
 Drawing corresponds to a PLPE050 / 1-stage / output shaft with feather key / 8 mm clamping system / motor adaptation - one part / B5 flange type motor
 所有其它变量可在 www.neugart.com 下 Tec Data Finder 中检索 - All other variants can be retrieved in the Tec Data Finder at www.neugart.com

几何尺寸 ⁽¹⁾	Geometry ⁽¹⁾			PLPE050	PLPE070	PLPE090	PLPE120	PLPE155	z ⁽²⁾	Code
输出端安装孔节圆直径	Pitch circle diameter output	D1		44	62	80	108	140		
输出轴直径	Shaft diameter output	D3	k7	12	16	22	32	40		
输出轴轴肩直径	Shaft collar output	D4		15	30	35	50	55		
输出端定位凸台直径	Centering diameter output	D5	h7	35	52	68	90	120		
箱体直径	Housing diameter	D6		50	70	90	120	155		
安装螺纹 x 深度	Mounting thread x depth	G1	4x	M4x8	M5x8	M6x9	M8x20	M10x20		
最小总长	Min. total length	L1		94	111	147	192	275,5	1	
				106,5	124	165	219,5	320	2	
箱体长度	Housing length	L2		46	51	67,5	76,5	100	1	
				58,5	64	85,5	104	144,5	2	
输出轴轴长	Shaft length output	L3		24,5	36	46	68	97		
输出端定位凸台深度	Centering depth output	L7		3	3	4	5	8		
输入端锁紧系统直径	Clamping system diameter input	D26		更多信息见 117 页 More information on page 117						
电机轴直径 j6/k6	Motor shaft diameter j6/k6	D20		具体尺寸视电机/减速机法兰而定。 可以在 www.neugart.com 下 Tec Data Finder. 针对每个电机适配电机特有的输入法兰几何尺寸 The dimensions vary with the motor/gearbox flange. The input flange geometries can be retrieved for each specific motor in Tec Data Finder at www.neugart.com						
最大允许的电机轴长	Max. permis. motor shaft length	L20								
最小允许的电机轴长	Min. permis. motor shaft length									
输入端定位凹槽直径	Centering diameter input	D21								
输入端定位凹槽深度	Centering depth input	L21								
输入端安装孔节圆直径	Pitch circle diameter input	D22								
输入法兰长度	Motor flange length	L22								
输入法兰对角线尺寸	Diagonal dimension input	D23								
安装螺纹 x 深度	Mounting thread x depth	G3	4x							
输入端法兰外方	Flange cross section input	Q3	■							
附带平键的输出轴 (DIN 6885-1)	Output shaft with feather key (DIN 6885-1)			A 4x4x14	A 5x5x25	A 6x6x32	A 10x8x50	A 12x8x70		A
平键宽度 (DIN 6885-1)	Feather key width (DIN 6885-1)	B1		4	5	6	10	12		
含平键在内的轴高 (DIN 6885-1)	Shaft height including feather key (DIN 6885-1)	H1		13,5	18	24,5	35	43		
到轴肩的距离	Shaft length from shoulder	L4		18	28	36	58	82		
平键长度	Feather key length	L5		14	25	32	50	70		
到轴端的距离	Distance from shaft end	L6		2	2	2	4	6		
中心孔 (DIN 332 DR 形)	Center hole (DIN 332, type DR)	Z		M4x10	M5x12,5	M8x19	M12x28	M16x36		
光滑输出轴	Smooth output shaft									B
到轴肩的距离	Shaft length from shoulder	L4		18	28	36	58	82		

⁽¹⁾ 所有的尺寸单位为mm
⁽²⁾ 减速机级数

⁽¹⁾ Dimensions in mm
⁽²⁾ Number of stages

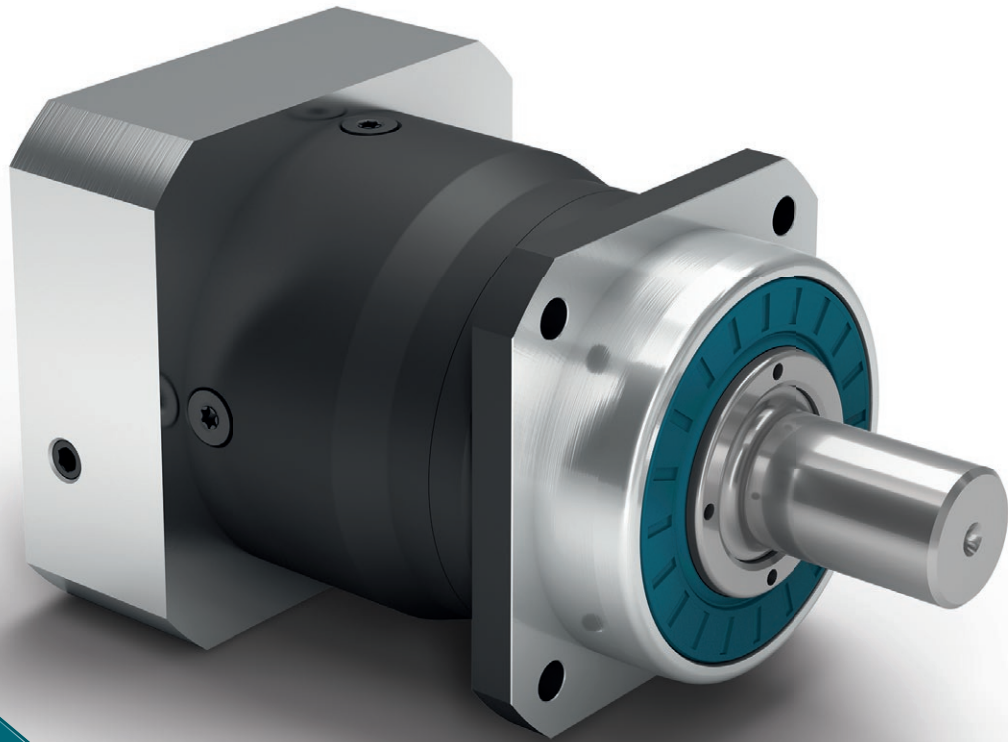

PLHE

这款行星减速机的进步之处在于： 集高精度和 经济性于一身

PLHE 是世界首款经济性与高精度完美结合的减速机。此款减速机配有预紧的圆锥滚子轴承，确保了很高的刚性和极佳的负载能力。我们研发的密封件能够完全防止灰尘和喷溅水进入机器内。

This is progress: In this planetary gearbox, precision and cost effectiveness meet

The PLHE is the world's first combination of economy and precision planetary gearboxes. The prestressed tapered roller bearings of our planetary gearboxes safeguard great stiffness even under the highest loads. The seal we have developed provides the perfect protection against dust and water jets.

- + 可安装在任意位置
- + 输入法兰可适配特殊的电机
- + 终生润滑，因此免维护
- + 旋转方向同向
- + 输出轴样式多样
- + 优化转动惯量的锁紧系统
- + 精确啮合

- + For any mounting position
- + Individual adaptation of the input flange to the motor
- + Lifetime lubrication for maintenance-free operation
- + Equidirectional rotation
- + Wide range of output shaft designs
- + Clamping systems with optimized mass moment of inertia
- + Precise gearing

1 完全密封

PLHE 在十分严苛的环境条件下也能有出色表现。我们自主研发的密封件配有预紧的径向轴环，能够防止灰尘和喷溅水进入机器。其防护等级为 IP65，借助智能型结构设计，PLHE 能够得到绝佳保护。

2 适用于重负载应用的输出轴承

PLHE 中预紧的圆锥滚子轴承确保了很高的刚性。即使运行方向频繁切换，输出轴承仍然能够保持零间隙。即使是持续负载，这款减速机也能从容应对。

3 两个领域的佼佼者

PLHE 是世界首款经济性与高精度完美结合的减速机。它结合了采购成本合理和高性能两大优点——完美集二者于一身。

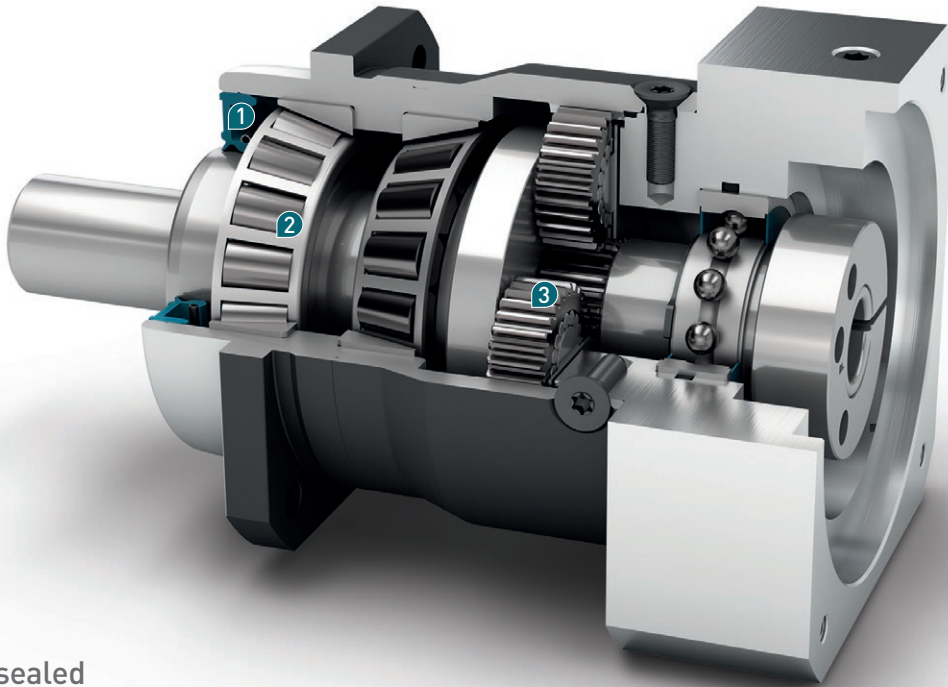

1 Perfectly sealed

The PLHE endures in the most grueling conditions. The prestressed radial shaft seal assembly we have designed even withstands dust and water jets. Perfect IP 65 protection class, thanks to its smart design.

2 Output bearing for heavy duty applications

The prestressed tapered roller bearings in the PLHE safeguard a high stiffness. Even under changing equidirectional rotations, the output bearings remain free of backlash. This gearbox perseveres under continuous loads.

3 The best of both worlds

The PLHE is the world's first combination of economy and precision planetary gearbox. It combines high performance with optimal acquisition costs – the perfect symbiosis.

Code	减速机参数	Gearbox characteristics			PLHE060	PLHE080	PLHE120	z ⁽¹⁾
	使用寿命	Service life	t _L	h	30.000			
	满载时效率 ⁽²⁾	Efficiency at full load ⁽²⁾	η	%	97			1
					96			2
	最低工作温度	Min. operating temperature	T _{min}	°C	-25			
	最高工作温度	Max. operating temperature	T _{max}		90			
	防护等级	Protection class			IP 65			
S	标准润滑	Standard lubrication			润滑脂 / Grease			
F	食品级润滑	Food grade lubrication			润滑脂 / Grease			
L	低温润滑 ⁽³⁾	Low temperature lubrication ⁽³⁾			润滑脂 / Grease			
	安装位置	Installation position			任意 / Any			
S	标准回程间隙	Standard backlash	j _t	arcmin	< 10	< 7	< 7	1
					< 12	< 9	< 9	2
	抗扭刚度 ⁽²⁾	Torsional stiffness ⁽²⁾	c _G	Nm / arcmin	2,2 - 3,0	6,0 - 8,0	13,4 - 18,0	1
					2,3 - 3,0	6,1 - 8,0	13,7 - 18,0	2
	减速机重量	Gearbox weight	m _G	kg	1,4	2,7	6,8	1
					1,6	3,4	8,8	2
S	标准的箱体表面	Standard surface			箱体: 钢 - 氮碳共渗和后氧化处理 (黑色) Housing: Steel - nitrocarburized and post-oxidized (black)			
	运行噪音 ⁽⁴⁾	Running noise ⁽⁴⁾	Q _G	dB(A)	58	60	65	
	基于减速机输入法兰的最大弯矩 ⁽⁵⁾	Max. bending moment based on the gearbox input flange ⁽⁵⁾	M _b	Nm	8	16	40	
	电机法兰精度	Motor flange precision			DIN 42955-N			

输出轴载荷	Output shaft loads			PLHE060	PLHE080	PLHE120	z ⁽¹⁾
20,000 h 的径向力 ⁽⁶⁾⁽⁷⁾	Radial force for 20,000 h ⁽⁶⁾⁽⁷⁾	F _{r20.000h}	N	3200	5500	6000	
20,000 h 的轴向力 ⁽⁶⁾⁽⁷⁾	Axial force for 20,000 h ⁽⁶⁾⁽⁷⁾	F _{a20.000h}		4400	6400	8000	
30,000 h 的径向力 ⁽⁶⁾⁽⁷⁾	Radial force for 30,000 h ⁽⁶⁾⁽⁷⁾	F _{r30.000h}		3200	4800	5400	
30,000 h 的轴向力 ⁽⁶⁾⁽⁷⁾	Axial force for 30,000 h ⁽⁶⁾⁽⁷⁾	F _{a30.000h}		3900	5700	7000	
静态径向力 ⁽⁷⁾⁽⁸⁾	Static radial force ⁽⁷⁾⁽⁸⁾	F _{r Stat}		3200	5500	6000	
静态轴向力 ⁽⁷⁾⁽⁸⁾	Static axial force ⁽⁷⁾⁽⁸⁾	F _{a Stat}		4400	6400	8000	
20,000 h 倾斜力矩 ⁽⁶⁾⁽⁸⁾	Tilting moment for 20,000 h ⁽⁶⁾⁽⁸⁾	M _{K20.000h}	Nm	191	383	488	
30,000 h 倾斜力矩 ⁽⁶⁾⁽⁸⁾	Tilting moment for 30,000 h ⁽⁶⁾⁽⁸⁾	M _{K30.000h}		191	335	439	

转动惯量	Moment of inertia			PLHE060	PLHE080	PLHE120	z ⁽¹⁾
转动惯量 ⁽²⁾	Mass moment of inertia ⁽²⁾	J	kgcm ²	0,069 - 0,178	0,370 - 0,775	1,390 - 2,486	1
				0,064 - 0,135	0,357 - 0,638	1,378 - 2,326	2

(1) 减速机级数

(2) 传动比相关的数值可在 Tec Data Finder 中检索 - www.neugart.com

(3) T_{min} = -40°C. 理想运行温度最高为 50°C

(4) 距离减速机 1 m 时; 在输入转速为 n₁=3000 min⁻¹ 且无负荷时测得; i=5

(5) 最大发动机重量* (单位: kg) = 0.2 × M_b / 发动机长度 (单位: m)

* 发动机重量对称分布

* 水平和固定的安装位置

(6) 数据以 n₂=100 min⁻¹ 的输出轴转速为准。

(7) 以输出轴中心为准

(8) 更改 T_{2N}, F_r, F_a 以及周期和轴承使用寿命时, 数值存在偏差 (部分较高)。利用 NCP 针对应用进行专门设计 - www.neugart.com

(1) Number of stages

(2) The ratio-dependent values can be retrieved in Tec Data Finder - www.neugart.com

(3) T_{min} = -40°C. Optimal operating temperature max. 50°C

(4) Sound pressure level from 1 m, measured on input running at n₁=3000 rpm no load; i=5

(5) Max. motor weight* in kg = 0.2 × M_b / motor length in m

* with symmetrically distributed motor weight

* with horizontal and stationary mounting

(6) These values are based on an output shaft speed of n₂=100 rpm

(7) Based on center of output shaft

(8) Other (sometimes higher) values following changes to T_{2N}, F_r, F_a, cycle, and service life of bearing. Application specific configuration with NCP - www.neugart.com

输出扭矩	Output torques			PLHE060	PLHE080	PLHE120	i ⁽¹⁾	z ⁽²⁾
额定输出扭矩 ⁽³⁾⁽⁴⁾	Nominal output torque ⁽³⁾⁽⁴⁾	T _{2N}	Nm	28	85	115	3	1
				38	115	155	4	
				40	110	195	5	
				25	65	135	7	
				18	50	120	8	
				15	38	95	10	
				44	130	210	9	2
				44	120	260	12	
				44	110	230	15	
				44	120	260	16	
				44	120	260	20	
				40	110	230	25	
				44	120	260	32	
				40	110	230	40	
				18	50	120	64	
				15	38	95	100	
最大输出扭矩 ⁽⁴⁾⁽⁵⁾	Max. output torque ⁽⁴⁾⁽⁵⁾	T _{2max}	Nm	45	136	184	3	1
				61	184	248	4	
				64	176	312	5	
				40	104	216	7	
				29	80	192	8	
				24	61	152	10	
				70	208	336	9	2
				70	192	416	12	
				70	176	368	15	
				70	192	416	16	
				70	192	416	20	
				64	176	368	25	
				70	192	416	32	
				64	176	368	40	
				29	80	192	64	
				24	61	152	100	

PLHE

⁽¹⁾ 传动比 (i=n₁/n₂)

⁽²⁾ 减速机级数

⁽³⁾ 利用 NCP 针对应用进行专门设计 – www.neugart.com

⁽⁴⁾ 平键 (代码 „A”)时的数值: 针对交变载荷

⁽⁵⁾ 允许输出轴转动30.000转; 参见第 128 页

⁽¹⁾ Ratios (i=n₁/n₂)

⁽²⁾ Number of stages

⁽³⁾ Application specific configuration with NCP – www.neugart.com

⁽⁴⁾ Values for feather key (code “A”): for repeated load

⁽⁵⁾ 30,000 rotations of the output shaft permitted; see page 129

输出扭矩	Output torques			PLHE060	PLHE080	PLHE120	i ⁽¹⁾	z ⁽²⁾
急停扭矩 ⁽³⁾	Emergency stop torque ⁽³⁾	T _{2Stop}	Nm	66	180	390	3	1
				88	240	520	4	
				80	220	500	5	
				80	178	340	7	
				80	190	380	8	
				80	200	480	10	
				88	260	500	9	2
				88	240	520	12	
				88	220	500	15	
				88	240	520	16	
				88	240	520	20	
				80	220	500	25	
				88	240	520	32	
				80	220	500	40	
				80	190	380	64	
				80	200	480	100	

输入转速	Input speeds			PLHE060	PLHE080	PLHE120	i ⁽¹⁾	z ⁽²⁾					
T _{2N} 和 S1 时的平均热输入转速 ⁽⁴⁾⁽⁵⁾	Average thermal input speed at T _{2N} and S1 ⁽⁴⁾⁽⁵⁾	n _{1N}	min ⁻¹	2950 ⁽⁶⁾	2450 ⁽⁶⁾	2150 ⁽⁶⁾	3	1					
				3500 ⁽⁶⁾	2700 ⁽⁶⁾	2400 ⁽⁶⁾	4						
				4200 ⁽⁶⁾	3250 ⁽⁶⁾	2600 ⁽⁶⁾	5						
				4500	4000	3500 ⁽⁶⁾	7						
				4500	4000	3500 ⁽⁶⁾	8						
				4500	4000	3500	10						
				4500 ⁽⁶⁾	4000 ⁽⁶⁾	3050 ⁽⁶⁾	9	2					
				4500	4000 ⁽⁶⁾	3200 ⁽⁶⁾	12						
				4500	4000	3500 ⁽⁶⁾	15						
				4500	4000	3500 ⁽⁶⁾	16						
				4500	4000	3500 ⁽⁶⁾	20						
				4500	4000	3500	25						
				4500	4000	3500	32						
				4500	4000	3500	40						
				4500	4000	3500	64						
				4500	4000	3500	100						
				最高机械输入转速 ⁽⁴⁾	Max. mechanical input speed ⁽⁴⁾	n _{1Limit}	min ⁻¹		13000	7000	6500		

⁽¹⁾ 传动比 (i=n₁/n₂)

⁽²⁾ 减速机级数

⁽³⁾ 允许 1000 次

⁽⁴⁾ 利用 NCP 针对应用设计转速 - www.neugart.com

⁽⁵⁾ 定义请参见第 128 页

⁽⁶⁾ 在 50% T_{2N} 输出和 S1 模式下的平均热传动转速

⁽¹⁾ Ratios (i=n₁/n₂)

⁽²⁾ Number of stages

⁽³⁾ Permitted 1000 times

⁽⁴⁾ Application-specific speed configurations with NCP - www.neugart.com

⁽⁵⁾ See page 129 for the definition

⁽⁶⁾ Average thermal input speed at 50% T_{2N} and S1

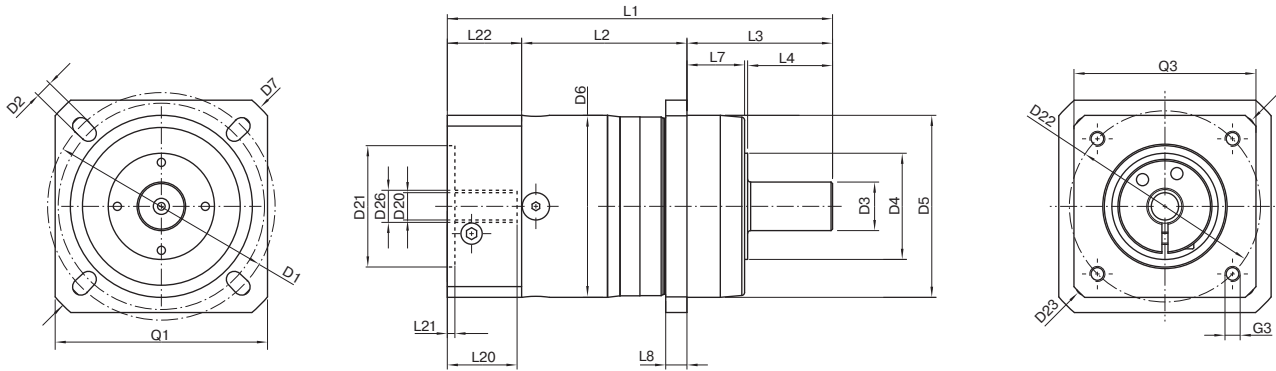

图示为带平键的 PLHE060 / 1 级 / 光滑输出轴 / 11 mm 锁紧系统 / 适配电机法兰 - 单一法兰 / B5 电机法兰类型
 Drawing corresponds to a PLHE060 / 1-stage / smooth output shaft / 11 mm clamping system / motor adaptation - one part / B5 flange type motor
 所有其它变量可在 www.neugart.com 下 Tec Data Finder 中检索 - All other variants can be retrieved in the Tec Data Finder at www.neugart.com

几何尺寸 ⁽¹⁾	Geometry ⁽¹⁾			PLHE060	PLHE080	PLHE120	z ⁽²⁾	Code			
输出端安装孔节圆直径	Pitch circle diameter output	D1		68 - 75	85	120					
输出端安装孔直径	Mounting bore output	D2	4x	5,5	6,5	9,0					
输出轴直径	Shaft diameter output	D3	k6	16	22	32					
输出轴轴肩直径	Shaft collar output	D4		35	40	45					
输出端定位凸台直径	Centering diameter output	D5	g7	60	70	90					
箱体直径	Housing diameter	D6		60	80	115					
输出法兰对角线尺寸	Diagonal dimension output	D7		92	100	140					
输出端法兰外方	Flange cross section output	Q1	■	70	80	110					
最小总长	Min. total length	L1		127	159,5	199,5	1				
				140	177	227	2				
箱体长度	Housing length	L2		55	69,5	64	1				
				67,5	87,5	91,5	2				
输出轴轴长	Shaft length output	L3		48	56	88					
输出端定位凸台深度	Centering depth output	L7		19	17,5	28					
输出端法兰厚度	Flange thickness output	L8		7	8	10					
输入端锁紧系统直径	Clamping system diameter input	D26		更多信息见第 117 页 More information on page 117							
电机轴直径 j6/k6	Motor shaft diameter j6/k6	D20		具体尺寸视电机/减速机法兰而定。 可以在 www.neugart.com 下 Tec Data Finder. 中针对每个电机适配电机特有的输入法兰几何尺寸 The dimensions vary with the motor/gearbox flange. The input flange geometries can be retrieved for each specific motor in Tec Data Finder at www.neugart.com							
最大允许的电机轴长	Max. permis. motor shaft length	L20									
最小允许的电机轴长	Min. permis. motor shaft length										
输入端定位凹槽直径	Centering diameter input	D21									
输入端定位凹槽深度	Centering depth input	L21									
输入端安装孔节圆直径	Pitch circle diameter input	D22									
输入法兰长度	Motor flange length	L22									
输入法兰对角线尺寸	Diagonal dimension input	D23									
安装螺纹 x 深度	Mounting thread x depth	G3	4x								
输入端法兰外方	Flange cross section input	Q3	■								
附带平键的输出轴 (DIN 6885-1)	Output shaft with feather key (DIN 6885-1)						A 5x5x25	A 6x6x28	A 10x8x50		A
平键宽度 (DIN 6885-1)	Feather key width (DIN 6885-1)	B1					5	6	10		
含平键在内的轴高 (DIN 6885-1)	Shaft height including feather key (DIN 6885-1)	H1					18	24,5	35		
到轴肩的距离	Shaft length from shoulder	L4		28	36	58					
平键长度	Feather key length	L5		25	28	50					
到轴端的距离	Distance from shaft end	L6		2	4	4					
中心孔 (DIN 332, type DR)	Center hole (DIN 332, type DR)	Z		M5x12,5	M8x19	M12x28					
光滑输出轴	Smooth output shaft							B			
到轴肩的距离	Shaft length from shoulder	L4		28	36	58					

⁽¹⁾ 所有的尺寸单位为mm
⁽²⁾ 减速机级数

⁽¹⁾ Dimensions in mm
⁽²⁾ Number of stages

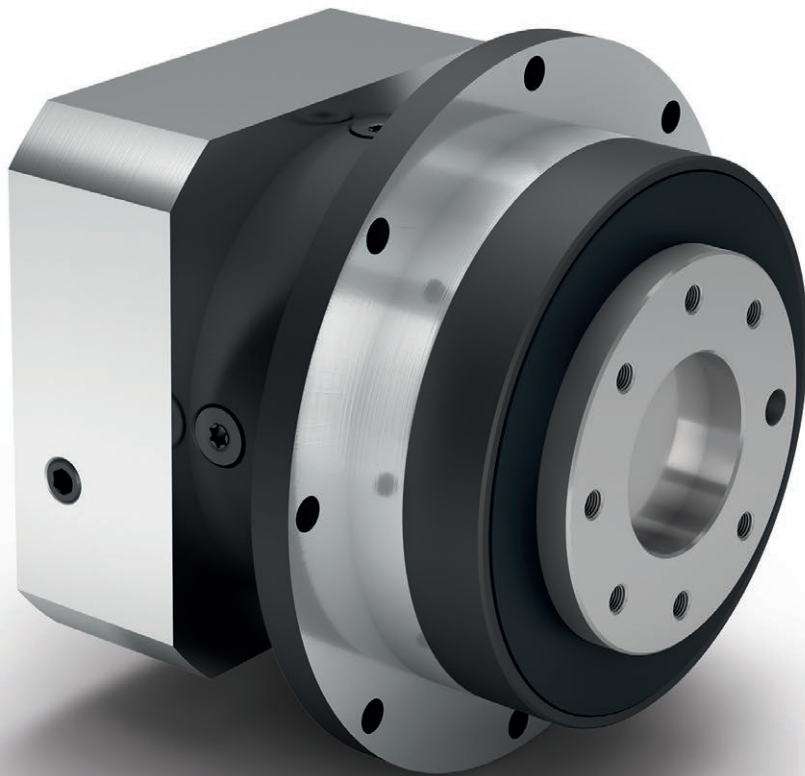

PLFE

结构最短的行星减速机 扭转刚度极高 采用法兰输出轴

前所未有的紧凑结构：**PLFE** 是一款配有紧凑型法兰输出轴的行星减速机。它可节省至少三分之一的空间，且扭转刚度提高了五倍。凭借其标准化的法兰接口，该行星减速机的安装极其简便。内置的定位销孔还为固定时的安全性提供了额外的保障。

The shortest planetary gearbox with the highest torsional stiffness and flange output shaft

There's no such thing as too short: The **PLFE** is our planetary gearbox with compact flange output shaft. You save more than a third of the space and benefit from a torsional stiffness that is five times higher than conventional products. Due to its standardized flange interface, it is especially easy to install. The integrated dowel hole provides additional security during fitting.

- + 可安装在任意位置
- + 输入法兰可适配特殊的电机
- + 终生润滑，因此免维护
- + 旋转方向同向
- + 优化转动惯量的锁紧系统
- + 精确啮合

- + For any mounting position
- + Individual adaptation of the input flange to the motor
- + Lifetime lubrication for maintenance-free operation
- + Equidirectional rotation
- + Clamping systems with optimized mass moment of inertia
- + Precise gearing

② 扭转刚度提高五倍

由于法兰输出轴的直径较大，**PLFE** 的扭转刚度比采用平键的输出轴高很多。这样就能使您的驱动解决方案达到最优化。

① 安装快捷安全

PLFE 标准化 (EN ISO 9409-1) 的法兰接口确保了驱动组件 (如皮带盘、线性元件或转盘给料机等) 的快捷安装。内置的定位销孔还为固定时的安全性提供了额外的保障。

③ 小巧精致

PLFE 比同类行星减速机短很多。视规格而定，其安装长度与同类传统产品相比最多可缩短 35%。

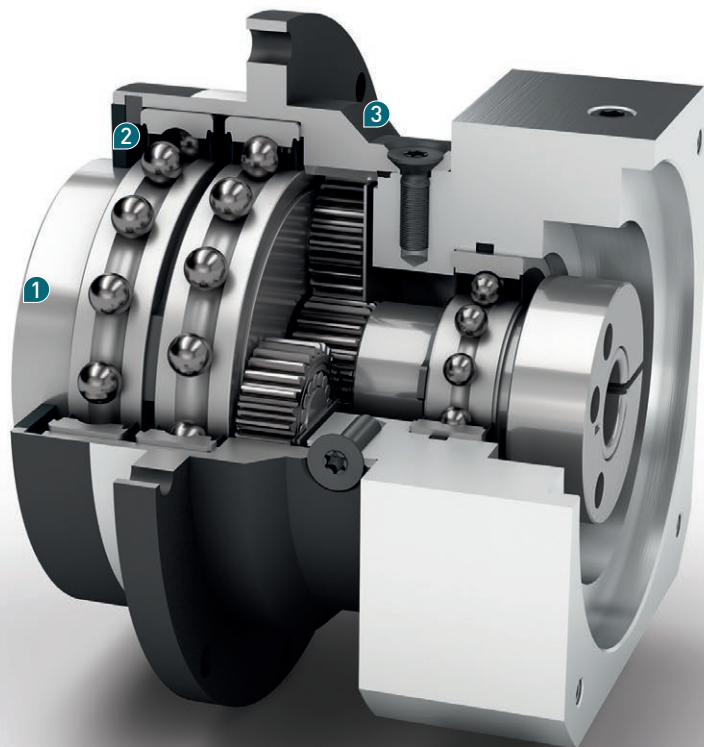

① Easy, reliable and fast installation

The standardized flange interface of the **PLFE** (EN ISO 9409-1) guarantees quick and easy mounting of the drive components, such as pulley, linear unit, or turntable. The integrated dowel hole provides additional security during fitting.

② Five times higher torsional stiffness

The large diameter of the flange output shaft gives the **PLFE** a considerably greater torsional stiffness than an output shaft with feather key. You therefore get the most out of your drive solution.

③ The compact miracle

The **PLFE** is considerably shorter than comparable planetary gearboxes. Depending on the frame size, the installed length is up to 35% less than comparable conventional products.

Code	减速机参数	Gearbox characteristics			PLFE064	PLFE090	PLFE110	z ⁽¹⁾
	使用寿命	Service life	t _L	h	30.000			
	满载时效率 ⁽²⁾	Efficiency at full load ⁽²⁾	η	%	98			1
					97			2
	最低工作温度	Min. operating temperature	T _{min}	°C	-25			
	最高工作温度	Max. operating temperature	T _{max}		90			
	防护等级	Protection class			IP 54			
S	标准润滑	Standard lubrication			润滑脂 / Grease			
F	食品级润滑	Food grade lubrication			润滑脂 / Grease			
L	低温润滑 ⁽³⁾	Low temperature lubrication ⁽³⁾			润滑脂 / Grease			
	安装位置	Installation position			任意 / Any			
S	标准回程间隙	Standard backlash	j _t	arcmin	< 10	< 7	< 7	1
					< 12	< 9	< 9	2
	抗扭刚度 ⁽²⁾	Torsional stiffness ⁽²⁾	c _G	Nm / arcmin	9,1 - 12,2	21,5 - 28,5	54,0 - 73,0	1
					9,3 - 12,2	22,0 - 28,5	55,0 - 72,0	2
	减速机重量	Gearbox weight	m _G	kg	1,1	2,9	7	1
					1,5	3,3	9	2
S	标准的箱体表面	Standard surface			箱体：钢 - 氮碳共渗和后氧化处理 (黑色) Housing: Steel - nitrocarburized and post-oxidized (black)			
	运行噪音 ⁽⁴⁾	Running noise ⁽⁴⁾	Q _G	dB(A)	58	60	65	
	基于减速机输入法兰的最大弯矩 ⁽⁵⁾	Max. bending moment based on the gearbox input flange ⁽⁵⁾	M _b	Nm	8	16	40	
	电机法兰精度	Motor flange precision			DIN 42955-N			

输出轴载荷	Output shaft loads			PLFE064	PLFE090	PLFE110	z ⁽¹⁾
20,000 h 的径向力 ⁽⁶⁾⁽⁷⁾	Radial force for 20,000 h ⁽⁶⁾⁽⁷⁾	F _{r20.000h}	N	550	1400	2400	
20,000 h 的轴向力 ⁽⁶⁾⁽⁷⁾	Axial force for 20,000 h ⁽⁶⁾⁽⁷⁾	F _{a20.000h}		1200	3000	3300	
30,000 h 的径向力 ⁽⁶⁾⁽⁷⁾	Radial force for 30,000 h ⁽⁶⁾⁽⁷⁾	F _{r30.000h}		500	1200	2100	
30,000 h 的轴向力 ⁽⁶⁾⁽⁷⁾	Axial force for 30,000 h ⁽⁶⁾⁽⁷⁾	F _{a30.000h}		1200	3000	3300	
静态径向力 ⁽⁷⁾⁽⁸⁾	Static radial force ⁽⁷⁾⁽⁸⁾	F _{r Stat}		900	2200	3800	
静态轴向力 ⁽⁷⁾⁽⁸⁾	Static axial force ⁽⁷⁾⁽⁸⁾	F _{a Stat}		1200	3300	5200	
20,000 h 倾斜力矩 ⁽⁶⁾⁽⁸⁾	Tilting moment for 20,000 h ⁽⁶⁾⁽⁸⁾	M _{K20.000h}	Nm	12	46	109	
30,000 h 倾斜力矩 ⁽⁶⁾⁽⁸⁾	Tilting moment for 30,000 h ⁽⁶⁾⁽⁸⁾	M _{K30.000h}		11	40	96	

转动惯量	Moment of inertia			PLFE064	PLFE090	PLFE110	z ⁽¹⁾
转动惯量 ⁽²⁾	Mass moment of inertia ⁽²⁾	J	kgcm ²	0,072 - 0,210	0,406 - 1,164	1,484 - 3,430	1
				0,064 - 0,130	0,356 - 0,666	1,377 - 2,407	2

(1) 减速机级数
 (2) 传动比相关的数值可在 Tec Data Finder 中检索 - www.neugart.com
 (3) T_{min} = -40°C. 理想运行温度最高为 50°C
 (4) 距离减速机 1 m 时; 在输入转速为 n₁=3000 min⁻¹ 且无负荷时测得; i=5
 (5) 最大发动机重量* (单位: kg) = 0.2 × M_b / 发动机长度 (单位: m)
 * 发动机重量对称分布
 * 水平和固定的安装位置
 (6) 数据以 n₂=100 min⁻¹ 的输出轴转速为准。
 (7) 基于输出轴末端
 (8) 更改 T_{2N}, F_r, F_a 以及周期和轴承使用寿命时, 数值存在偏差 (部分较高)。利用 NCP 针对应用进行专门设计 - www.neugart.com

(1) Number of stages
 (2) The ratio-dependent values can be retrieved in Tec Data Finder - www.neugart.com
 (3) T_{min} = -40°C. Optimal operating temperature max. 50°C
 (4) Sound pressure level from 1 m, measured on input running at n₁=3000 rpm no load; i=5
 (5) Max. motor weight* in kg = 0.2 × M_b / motor length in m
 * with symmetrically distributed motor weight
 * with horizontal and stationary mounting
 (6) These values are based on an output shaft speed of n₂=100 rpm
 (7) Based on the end of the output shaft
 (8) Other (sometimes higher) values following changes to T_{2N}, F_r, F_a, cycle, and service life of bearing. Application specific configuration with NCP - www.neugart.com

输出扭矩	Output torques			PLFE064	PLFE090	PLFE110	$i^{(1)}$	$z^{(2)}$
额定输出扭矩 ⁽³⁾	Nominal output torque ⁽³⁾	T_{2N}	Nm	28	85	115	3	1
				38	115	155	4	
				40	110	195	5	
				25	65	135	7	
				18	50	120	8	
				15	38	95	10	
				44	130	240	9	2
				44	120	260	12	
				44	110	230	15	
				44	120	260	16	
				44	120	260	20	
				40	110	230	25	
				44	120	260	32	
				40	110	230	40	
				18	50	120	64	
				15	38	95	100	
最大输出扭矩 ⁽⁴⁾	Max. output torque ⁽⁴⁾	T_{2max}	Nm	45	136	184	3	1
				61	184	248	4	
				64	176	312	5	
				40	104	216	7	
				29	80	192	8	
				24	61	152	10	
				70	208	384	9	2
				70	192	416	12	
				70	176	368	15	
				70	192	416	16	
				70	192	416	20	
				64	176	368	25	
				70	192	416	32	
				64	176	368	40	
				29	80	192	64	
				24	61	152	100	

PLFE

⁽¹⁾ 传动比 ($i=n_1/n_2$)

⁽²⁾ 减速机级数

⁽³⁾ 利用 NCP 针对应用进行专门设计 – www.neugart.com

⁽⁴⁾ 允许输出轴转动30,000转；参见第 128 页

⁽¹⁾ Ratios ($i=n_1/n_2$)

⁽²⁾ Number of stages

⁽³⁾ Application specific configuration with NCP – www.neugart.com

⁽⁴⁾ 30,000 rotations of the output shaft permitted; see page 129

输出扭矩	Output torques			PLFE064	PLFE090	PLFE110	i ⁽¹⁾	z ⁽²⁾
急停扭矩 ⁽³⁾	Emergency stop torque ⁽³⁾	T _{2Stop}	Nm	66	180	390	3	1
				88	240	520	4	
				80	220	500	5	
				80	178	340	7	
				80	190	380	8	
				80	200	480	10	
				88	260	500	9	2
				88	240	520	12	
				88	220	500	15	
				88	240	520	16	
				88	240	520	20	
				80	220	500	25	
				88	240	520	32	
				80	220	500	40	
				80	190	380	64	
				80	200	480	100	

输入转速	Input speeds			PLFE064	PLFE090	PLFE110	i ⁽¹⁾	z ⁽²⁾
T _{2N} 和 S1 时的平均热输入转速 ⁽⁴⁾⁽⁵⁾	Average thermal input speed at T _{2N} and S1 ⁽⁴⁾⁽⁵⁾	n _{1N}	min ⁻¹	3950 ⁽⁶⁾	2800 ⁽⁶⁾	2350 ⁽⁶⁾	3	1
				4500 ⁽⁶⁾	3000 ⁽⁶⁾	2550 ⁽⁶⁾	4	
				4500 ⁽⁶⁾	3550 ⁽⁶⁾	2700 ⁽⁶⁾	5	
				4500	4000	3500 ⁽⁶⁾	7	
				4500	4000	3500 ⁽⁶⁾	8	
				4500	4000	3500	10	
				4500 ⁽⁶⁾	4000 ⁽⁶⁾	2850 ⁽⁶⁾	9	2
				4500	4000 ⁽⁶⁾	3100 ⁽⁶⁾	12	
				4500	4000	3500 ⁽⁶⁾	15	
				4500	4000	3500 ⁽⁶⁾	16	
				4500	4000	3500 ⁽⁶⁾	20	
				4500	4000	3500	25	
				4500	4000	3500	32	
				4500	4000	3500	40	
				4500	4000	3500	64	
				4500	4000	3500	100	
最高机械输入转速 ⁽⁴⁾	Max. mechanical input speed ⁽⁴⁾	n _{1Limit}	min ⁻¹	13000	7000	6500		

⁽¹⁾ 传动比 (i=n₁/n₂)

⁽²⁾ 减速机级数

⁽³⁾ 允许 1000 次

⁽⁴⁾ 利用 NCP 针对应用设计转速 - www.neugart.com

⁽⁵⁾ 定义请参见第 128 页

⁽⁶⁾ 在 50% T_{2N} 输出和 S1 模式下的平均热传动转速

⁽¹⁾ Ratios (i=n₁/n₂)

⁽²⁾ Number of stages

⁽³⁾ Permitted 1000 times

⁽⁴⁾ Application-specific speed configurations with NCP - www.neugart.com

⁽⁵⁾ See page 129 for the definition

⁽⁶⁾ Average thermal input speed at 50% T_{2N} and S1

PLFE064
PLFE090

PLFE110

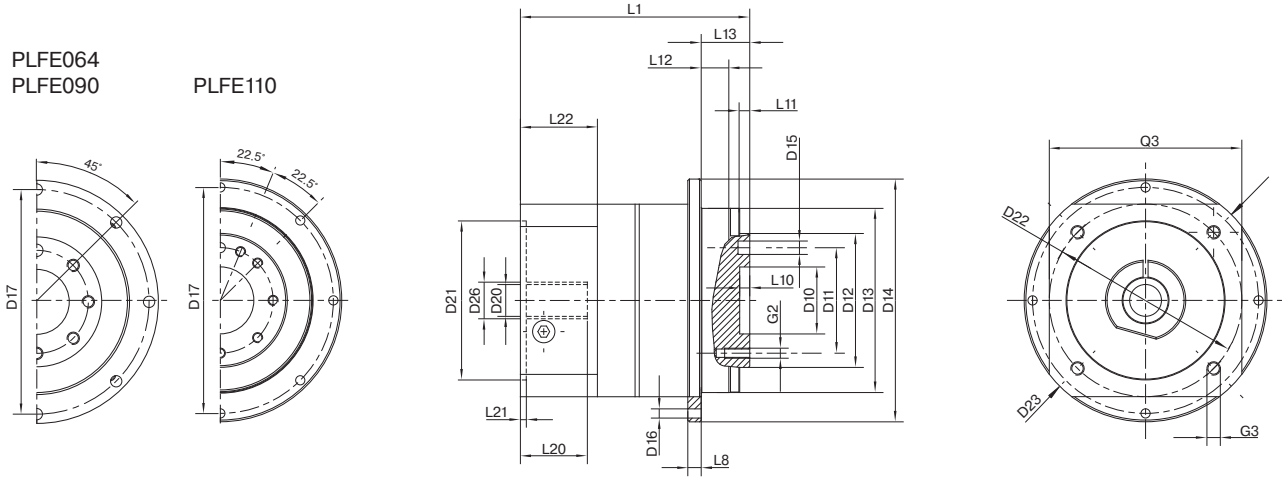

图示为带平键的 PLFE110 / 1 级 / 带有配合销孔的法兰输出轴 / 24 mm 锁紧系统 / 适配电机法兰 - 单一法兰 / B5 电机法兰类型
 Drawing corresponds to a PLFE110 / 1-stage / flange output shaft with dowel hole / 24 mm clamping system / motor adaptation - one part / B5 flange type motor
 所有其它变量可在 www.neugart.com 下 Tec Data Finder 中检索 - All other variants can be retrieved in the Tec Data Finder at www.neugart.com

几何尺寸 ⁽¹⁾	Geometry ⁽¹⁾			PLFE064	PLFE090	PLFE110	z ⁽²⁾	Code
输出端定位凹槽直径	Centering diameter output shaft	D10	H7	20	31,5	40		
输出端安装孔节圆直径	Pitch circle Ø output shaft	D11		31,5	50	63		
输出轴定位凸台直径	Centering diameter output shaft	D12	h7	40	63	80		
输出法兰定位凸台直径	Centering Ø output flange	D13		64	90	110		
输出法兰直径	Flange diameter output	D14		86	118	145		
输出端安装孔直径	Mounting bore output	D16		4,5 8x45°	5,5 8x45°	5,5 8x45°		
输出法兰安装孔节圆直径	Pitch circle Ø output flange	D17		79	109	135		
最小总长	Min. total length	L1		69	98,5	125,5	1	
				81,5	116	152,5	2	
输出端法兰厚度	Flange thickness output	L8		4	7	8		
输出轴定位凸台深度	Centering depth output shaft	L10		4	6	6		
		L11		3	6	6		
输出法兰定位凸台深度	Centering depth output flange	L12		7,5	10,5	10,5		
输出法兰长度	Output flange length	L13		19,5	30	29		
输入端锁紧系统直径	Clamping system diameter input	D26	更多信息见第 117 页 More information on page 117					
电机轴直径 j6/k6	Motor shaft diameter j6/k6	D20	具体尺寸视电机/减速机法兰而定。 可以在 www.neugart.com 下 Tec Data Finder 中针对每个电机适配电机特有的输入法兰几何尺寸 The dimensions vary with the motor/gearbox flange. The input flange geometries can be retrieved for each specific motor in Tec Data Finder at www.neugart.com					
最大允许的电机轴长	Max. permis. motor shaft length	L20						
最小允许的电机轴长	Min. permis. motor shaft length							
输入端定位凹槽直径	Centering diameter input	D21						
输入端定位凹槽深度	Centering depth input	L21						
输入端安装孔节圆直径	Pitch circle diameter input	D22						
输入法兰长度	Motor flange length	L22						
输入法兰对角线尺寸	Diagonal dimension input	D23						
安装螺纹 x 深度	Mounting thread x depth	G3					4x	
输入端法兰外方	Flange cross section input	Q3					■	
带有配合销孔的法兰输出轴 (EN ISO 9409-1)	Flange output shaft with dowel hole (EN ISO 9409-1)						E	
配合销孔 x 深度	Dowel hole x depth	D15	H7	5x6	6x7	6x7		
数量 x 螺纹 x 深度	Number x thread x depth	G2		7 x M5x7	7 x M6x10	11 x M6x12		

⁽¹⁾ 所有的尺寸单位为mm
⁽²⁾ 减速机级数

⁽¹⁾ Dimensions in mm
⁽²⁾ Number of stages

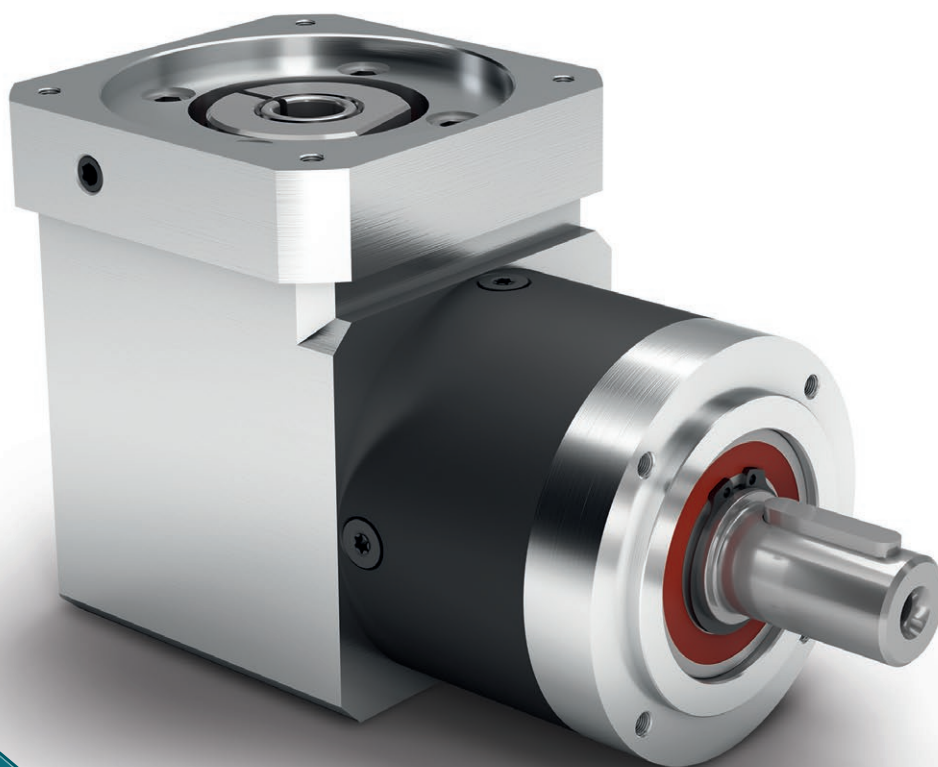

WPLE

直角行星减速机 轻巧 经济性较高

WPLE 在不断将经济型产品系列的优势发扬光大。凭借其紧凑但有力的结构型式，它成为了动态多轴系统的理想选择。我们的直角减速机终生润滑免维护，安装时简单易操作，堪称性价比之王。

The versatile right angle planetary gearbox with lower weight and appealing cost effectiveness

The WPLE is a consistent continuation of the benefits offered by the Economy Line. With its compact, but powerful design, it is ideal for dynamic multiple axis systems. Our right angle gearbox features lifetime lubrication, is easy to install, all this at an unrivalled price-performance ratio.

- ⊕ 输入法兰可适配特殊的电机
- ⊕ 终生润滑，因此免维护
- ⊕ 旋转方向同向
- ⊕ 输出轴样式多样
- ⊕ 精确啮合
- ⊕ 传动比范围广，从 $i = 3$ 到 $i = 512$

- ⊕ Individual adaptation of the input flange to the motor
- ⊕ Lifetime lubrication for maintenance-free operation
- ⊕ Equidirectional rotation
- ⊕ Wide range of output shaft designs
- ⊕ Precise gearing
- ⊕ Wide range of ratios $i = 3$ to $i = 512$

1 多轴系统中极高的动态性

WPLE 直角减速机的性能比一般同类产品优秀许多：其自重降低了 25%，因此扭矩极高。

2 有效且高效

作为直角行星减速机系列中的全能型产品，WPLE 又是多功能产品中的专家，这就为它带来了无可比拟的性价比。

3 安装灵活可靠

使用此款终生润滑免维护的 WPLE 直角行星减速机，有限的空间也能得到充分的利用。此款减速机安装灵活，因此适用的应用情况十分广泛。

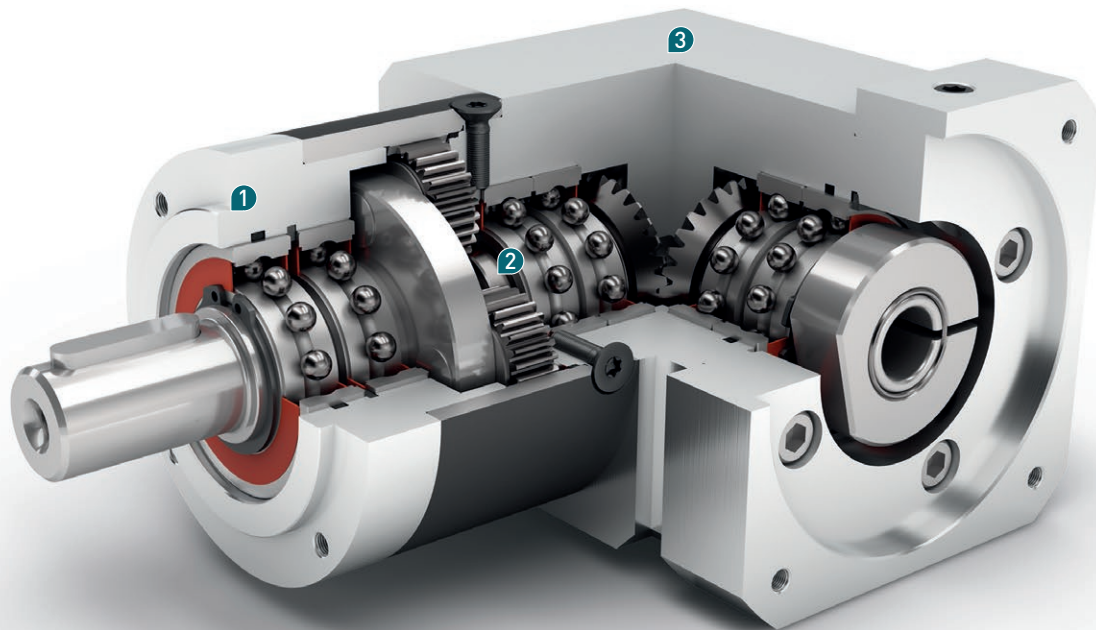

1 The highest dynamics in multiple axis systems

The WPLE right angle gearbox delivers more than just above average performance: With 25% less weight, it outputs a particularly high torque.

2 Efficient and effective

As a genuine multi-talent of right angle planetary gearboxes, the WPLE is the specialist among the generalists – and that at an unbeatable price-performance ratio.

3 Flexible installation options and reliability

Fitted with lifetime lubrication, our WPLE right angle planetary gearbox lets you exploit restricted space to the optimal extent. It can be installed in any direction, making it the ideal choice for many applications.

Code	减速机参数	Gearbox characteristics			WPLE040	WPLE060	WPLE080	WPLE120	z ⁽¹⁾
	使用寿命	Service life	t _L	h	20.000				
	T _{2N} × 0.88 时的使用寿命	Service life at T _{2N} × 0.88			30.000				
	满载时效率 ⁽²⁾	Efficiency at full load ⁽²⁾	η	%	95				1
					94				2
					88				3
	最低工作温度	Min. operating temperature	T _{min}	°C	-25				
	最高工作温度	Max. operating temperature	T _{max}		90				
	防护等级	Protection class			IP 54				
S	标准润滑	Standard lubrication			润滑脂 / Grease				
F	食品级润滑	Food grade lubrication			润滑脂 / Grease				
L	低温润滑 ⁽³⁾	Low temperature lubrication ⁽³⁾			润滑脂 / Grease				
	安装位置	Installation position			任意 / Any				
S	标准回程间隙	Standard backlash	j _t	arcmin	< 21	< 16	< 13	< 11	1
					< 25	< 18	< 15	< 13	2
					< 28	< 21	< 17	< 15	3
	抗扭刚度 ⁽²⁾	Torsional stiffness ⁽²⁾	c _g	Nm / arcmin	0,6 - 0,8	1,5 - 2,0	3,8 - 5,1	9,6 - 12,9	1
					0,6 - 0,8	1,6 - 2,0	4,1 - 5,1	10,4 - 12,9	2
					0,6 - 0,8	1,5 - 2,0	3,9 - 5,1	9,9 - 12,9	3
	减速机重量	Gearbox weight	m _G	kg	0,5	1,7	4,4	12	1
					0,6	1,9	5	14	2
					0,7	2,1	5,5	16	3
S	标准的箱体表面	Standard surface			箱体: 钢 - 氮碳共渗和后氧化处理 (黑色) Housing: Steel - nitrocarburized and post-oxidized (black)				
	运行噪音 ⁽⁴⁾	Running noise ⁽⁴⁾	Q _g	dB(A)	68	70	73	75	
	基于减速机输入法兰的最大弯矩 ⁽⁵⁾	Max. bending moment based on the gearbox input flange ⁽⁵⁾	M _b	Nm	2	5	10,5	26	
	电机法兰精度	Motor flange precision			DIN 42955-N				

输出轴载荷	Output shaft loads			WPLE040	WPLE060	WPLE080	WPLE120	z ⁽¹⁾
20,000 h 的径向力 ⁽⁶⁾⁽⁷⁾	Radial force for 20,000 h ⁽⁶⁾⁽⁷⁾	F _{r20.000h}	N	200	400	750	1750	
20,000 h 的轴向力 ⁽⁶⁾⁽⁷⁾	Axial force for 20,000 h ⁽⁶⁾⁽⁷⁾	F _{a20.000h}		200	500	1000	2500	
30,000 h 的径向力 ⁽⁶⁾⁽⁷⁾	Radial force for 30,000 h ⁽⁶⁾⁽⁷⁾	F _{r30.000h}		160	340	650	1500	
30,000 h 的轴向力 ⁽⁶⁾⁽⁷⁾	Axial force for 30,000 h ⁽⁶⁾⁽⁷⁾	F _{a30.000h}		160	450	900	2100	
静态径向力 ⁽⁷⁾⁽⁸⁾	Static radial force ⁽⁷⁾⁽⁸⁾	F _{r Stat}		200	700	1250	2000	
静态轴向力 ⁽⁷⁾⁽⁸⁾	Static axial force ⁽⁷⁾⁽⁸⁾	F _{a Stat}		240	800	1600	3800	
20,000 h 倾斜力矩 ⁽⁶⁾⁽⁸⁾	Tilting moment for 20,000 h ⁽⁶⁾⁽⁸⁾	M _{K20.000h}	Nm	5	14	31	101	
30,000 h 倾斜力矩 ⁽⁶⁾⁽⁸⁾	Tilting moment for 30,000 h ⁽⁶⁾⁽⁸⁾	M _{K30.000h}		4	12	27	86	

转动惯量	Moment of inertia			WPLE040	WPLE060	WPLE080	WPLE120	z ⁽¹⁾
转动惯量 ⁽²⁾	Mass moment of inertia ⁽²⁾	J	kgcm ²	0,032 - 0,049	0,221 - 0,376	0,917 - 1,409	1,849 - 3,204	1
				0,032 - 0,049	0,223 - 0,378	0,931 - 1,424	1,919 - 3,397	2
				0,032 - 0,048	0,223 - 0,240	0,931 - 1,368	1,919 - 3,175	3

(1) 减速机级数
 (2) 传动比相关的数值可在 Tec Data Finder 中检索 - www.neugart.com
 (3) T_{min} = -40°C. 理想运行温度最高为 50°C
 (4) 距离减速机 1 m 时; 在输入转速为 n₁=3000 min⁻¹ 且无负荷时测得; i=5
 (5) 最大发动机重量* (单位: kg) = 0.2 × M_b / 发动机长度 (单位: m)
 * 发动机重量对称分布
 * 水平和固定的安装位置
 (6) 数据以 n₂=100 min⁻¹ 的输出轴转速为准。
 (7) 以输出轴中心为准
 (8) 更改 T_{2N}, F_r, F_a 以及周期和轴承使用寿命时, 数值存在偏差 (部分较高)。利用 NCP 针对应用进行专门设计 - www.neugart.com

(1) Number of stages
 (2) The ratio-dependent values can be retrieved in Tec Data Finder - www.neugart.com
 (3) T_{min} = -40°C. Optimal operating temperature max. 50°C
 (4) Sound pressure level from 1 m, measured on input running at n₁=3000 rpm no load; i=5
 (5) Max. motor weight* in kg = 0.2 × M_b / motor length in m
 * with symmetrically distributed motor weight
 * with horizontal and stationary mounting
 (6) These values are based on an output shaft speed of n₂=100 rpm
 (7) Based on center of output shaft
 (8) Other (sometimes higher) values following changes to T_{2N}, F_r, F_a, cycle, and service life of bearing. Application specific configuration with NCP - www.neugart.com

输出扭矩	Output torques			WPLE040	WPLE060	WPLE080	WPLE120	i ⁽¹⁾	z ⁽²⁾
额定输出扭矩 ⁽³⁾⁽⁴⁾	Nominal output torque ⁽³⁾⁽⁴⁾	T _{2N}	Nm	4,5	14	40 ⁽⁵⁾	80 ⁽⁵⁾	3	1
				6	19	53 ⁽⁵⁾	105 ⁽⁵⁾	4	
				7,5	24	67 ⁽⁵⁾	130 ⁽⁵⁾	5	
				8,5	25	65	135	7	
				6	18	50	120	8	
				5	15	38	95	10	
				16,5 ⁽⁵⁾	44 ⁽⁵⁾	130 ⁽⁵⁾	210 ⁽⁵⁾	9	2
				20 ⁽⁵⁾	44	120 ⁽⁵⁾	260 ⁽⁵⁾	12	
				18 ⁽⁵⁾	44	110	230	15	
				20 ⁽⁵⁾	44	120	260	16	
				20 ⁽⁵⁾	44	120	260	20	
				18	40	110	230	25	3
				20	44	120	260	32	
				18	40	110	230	40	
				7,5	18	50	120	64	
				20	44	110	260	60	
				20	44	120	260	80	
				20	44	120	260	100	
				18	44	110	230	120	
				20	44	120	260	160	
18	40	110	230	200					
20	44	120	260	256					
18	40	110	230	320					
7,5	18	50	120	512					
最大输出扭矩 ⁽⁴⁾⁽⁶⁾	Max. output torque ⁽⁴⁾⁽⁶⁾	T _{2max}	Nm	7	22	64	128	3	1
				10	30	85	168	4	
				12	38	107	208	5	
				13,5	40	104	216	7	
				10	29	80	192	8	
				8	24	61	152	10	
				26	70	208	336	9	2
				32	70	192	416	12	
				29	70	176	368	15	
				32	70	192	416	16	
				32	70	192	416	20	
				29	64	176	368	25	3
				32	70	192	416	32	
				29	64	176	368	40	
				12	29	80	192	64	
				32	70	176	416	60	
				32	70	192	416	80	
				32	70	192	416	100	
				29	70	176	368	120	
				32	70	192	416	160	
29	64	176	368	200					
32	70	192	416	256					
29	64	176	368	320					
12	29	80	192	512					

(1) 传动比 (i=n₁/n₂)
 (2) 减速机级数
 (3) 利用 NCP 针对应用进行专门设计 – www.neugart.com
 (4) 平键 (代码 „A”)时的数值: 针对交变载荷
 (5) T_{2N} 作用时 寿命不是10,000 h
 (6) 允许输出轴转动30,000转; 参见第 128 页

(1) Ratios (i=n₁/n₂)
 (2) Number of stages
 (3) Application specific configuration with NCP – www.neugart.com
 (4) Values for feather key (code "A"): for repeated load
 (5) Different service life: 10,000 h at T_{2N}
 (6) 30,000 rotations of the output shaft permitted; see page 129

输出扭矩	Output torques			WPLE040	WPLE060	WPLE080	WPLE120	i ⁽¹⁾	z ⁽²⁾
急停扭矩 ⁽³⁾	Emergency stop torque ⁽³⁾	T _{2Stop}	Nm	22,5	66	180	360	3	1
				28	86	240	474	4	
				35	80	220	500	5	
				26	80	178	340	7	
				27	80	190	380	8	
				25	70	170	430	10	
				33	88	260	500	9	2
				40	88	240	520	12	
				36	88	220	500	15	
				40	88	240	520	16	
				40	88	240	520	20	
				36	80	220	500	25	
				40	88	240	520	32	3
				36	80	220	500	40	
				27	80	190	380	64	
				40	88	220	520	60	
				40	88	240	520	80	
				40	88	240	520	100	
				36	88	220	500	120	3
				40	88	240	520	160	
36	80	220	500	200					
40	88	240	520	256					
36	80	220	500	320					
27	80	190	380	512					

输入转速	Input speeds			WPLE040	WPLE060	WPLE080	WPLE120	i ⁽¹⁾	z ⁽²⁾
T _{2N} 和 S1 时的平均热输入转速 ⁽⁴⁾⁽⁵⁾	Average thermal input speed at T _{2N} and S1 ⁽⁴⁾⁽⁵⁾	n _{1N}	min ⁻¹	5000	4500 ⁽⁶⁾	3500 ⁽⁶⁾	2850 ⁽⁶⁾	3	1
				5000	4500 ⁽⁶⁾	3550 ⁽⁶⁾	2950 ⁽⁶⁾	4	
				5000	4500 ⁽⁶⁾	3600 ⁽⁶⁾	3050 ⁽⁶⁾	5	
				5000	4500	4000 ⁽⁶⁾	3500 ⁽⁶⁾	7	
				5000	4500	4000 ⁽⁶⁾	3500 ⁽⁶⁾	8	
				5000	4500	4000	3500	10	
				5000	4500 ⁽⁶⁾	3250 ⁽⁶⁾	2950 ⁽⁶⁾	9	2
				5000	4500 ⁽⁶⁾	3850 ⁽⁶⁾	3050 ⁽⁶⁾	12	
				5000	4500	4000 ⁽⁶⁾	3500 ⁽⁶⁾	15	
				5000	4500	4000 ⁽⁶⁾	3450 ⁽⁶⁾	16	
				5000	4500	4000 ⁽⁶⁾	3500 ⁽⁶⁾	20	
				5000	4500	4000	3500 ⁽⁶⁾	25	
				5000	4500	4000	3500	32	3
				5000	4500	4000	3500	40	
				5000	4500	4000	3500	64	
				5000	4500	4000	3500	60	
				5000	4500	4000	3500	80	
				5000	4500	4000	3500	100	
				5000	4500	4000	3500	120	3
				5000	4500	4000	3500	160	
5000	4500	4000	3500	200					
5000	4500	4000	3500	256					
5000	4500	4000	3500	320					
5000	4500	4000	3500	512					
最高机械输入转速 ⁽⁴⁾	Max. mechanical input speed ⁽⁴⁾	n _{1Limit}	min ⁻¹	18000	13000	7000	6500		

(1) 传动比 (i=n₁/n₂)

(2) 减速级数

(3) 允许 1000 次

(4) 利用 NCP 针对应用设计转速 - www.neugart.com

(5) 定义请参见第 128 页

(6) 在 50% T_{2N} 输出和 S1 模式下的平均热传动转速

(1) Ratios (i=n₁/n₂)

(2) Number of stages

(3) Permitted 1000 times

(4) Application-specific speed configurations with NCP - www.neugart.com

(5) See page 129 for the definition

(6) Average thermal input speed at 50% T_{2N} and S1

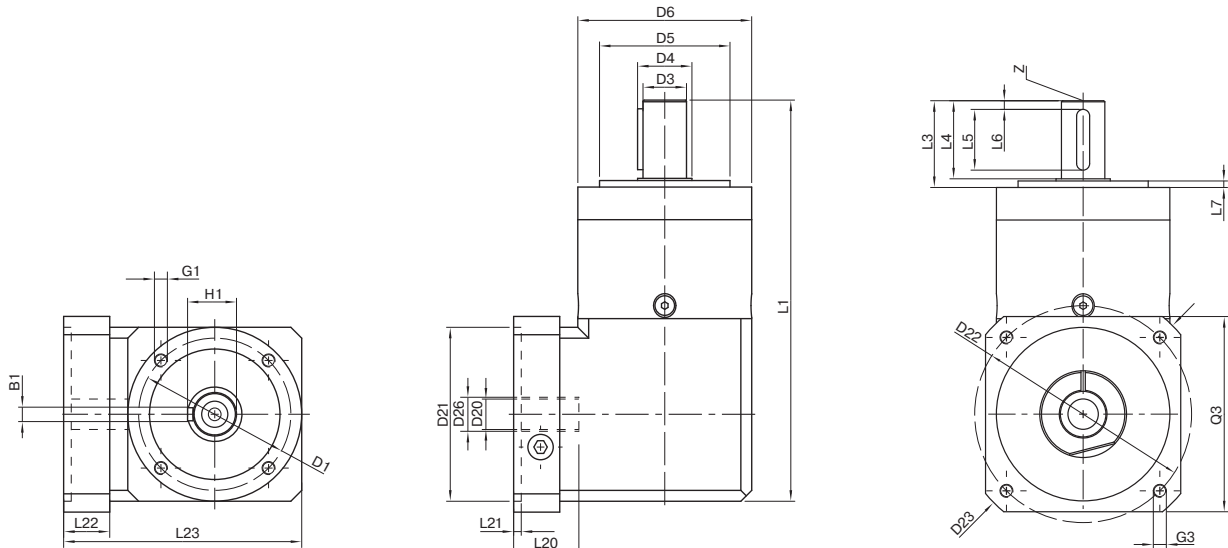

图示为带平键的 WPLE080 / 1 级 / 附带平键的输出轴 / 19 mm 锁紧系统 / 适配电机法兰 - 2 件式 - 正方形通用法兰 / B5 电机法兰类型
 Drawing corresponds to a WPLE080 / 1-stage / output shaft with feather key / 19 mm clamping system / motor adaptation - 2-part - square universal flange / B5 flange type motor
 所有其它变量可在 www.neugart.com 下 Tec Data Finder 中检索 - All other variants can be retrieved in the Tec Data Finder at www.neugart.com

几何尺寸 ⁽¹⁾	Geometry ⁽¹⁾			WPLE040	WPLE060	WPLE080	WPLE120	z ⁽²⁾	Code
输出端安装孔节圆直径	Pitch circle diameter output	D1		34	52	70	100		
输出轴直径	Shaft diameter output	D3	h7	10	14	20	25		
输出轴轴肩直径	Shaft collar output	D4		12	17	25	35		
输出端定位凸台直径	Centering diameter output	D5	h7	26	40	60	80		
箱体直径	Housing diameter	D6		40	60	80	115		
安装螺纹 x 深度	Mounting thread x depth	G1	4x	M4x6	M5x8	M6x10	M10x16		
总长	Total length	L1		110	147	184	249,5	1	
				123	159,5	201,5	277	2	
				135,5	172	219	304,5	3	
输出轴轴长	Shaft length output	L3		26	35	40	55		
输出端定位凸台深度	Centering depth output	L7		2	3	3	4		
最小总高度	Min. overall height	L23		62	86	110	146		
输入端锁紧系统直径	Clamping system diameter input	D26		更多信息见第 117 页 More information on page 117					
电机轴直径 j6/k6	Motor shaft diameter j6/k6	D20		具体尺寸视电机/减速机法兰而定。 可以在 www.neugart.com 下 Tec Data Finder. 中针对每个电机适配电机特有的输入法兰几何尺寸 The dimensions vary with the motor/gearbox flange. The input flange geometries can be retrieved for each specific motor in Tec Data Finder at www.neugart.com -					
最大允许的电机轴长	Max. permis. motor shaft length	L20							
最小允许的电机轴长	Min. permis. motor shaft length								
输入端定位凹槽直径	Centering diameter input	D21							
输入端定位凹槽深度	Centering depth input	L21							
输入端安装孔节圆直径	Pitch circle diameter input	D22							
输入法兰长度	Motor flange length	L22							
输入法兰对角线尺寸	Diagonal dimension input	D23							
安装螺纹 x 深度	Mounting thread x depth	G3	4x						
输入端法兰外方	Flange cross section input	Q3	■						
附带平键的输出轴 (DIN 6885-1)	Output shaft with feather key (DIN 6885-1)			A 3x3x18	A 5x5x25	A 6x6x28	A 8x7x40		A
平键宽度 (DIN 6885-1)	Feather key width (DIN 6885-1)	B1		3	5	6	8		
含平键在内的轴高 (DIN 6885-1)	Shaft height including feather key (DIN 6885-1)	H1		11,2	16	22,5	28		
到轴肩的距离	Shaft length from shoulder	L4		23	30	36	50		
平键长度	Feather key length	L5		18	25	28	40		
到轴端的距离	Distance from shaft end	L6		2,5	2,5	4	5		
中心孔 (DIN 332, DR 形)	Center hole (DIN 332, type DR)	Z		M3x9	M5x12,5	M6x16	M10x22		
光滑输出轴	Smooth output shaft								B
到轴肩的距离	Shaft length from shoulder	L4		23	30	36	50		

⁽¹⁾ 所有的尺寸单位为mm
⁽²⁾ 减速机级数

⁽¹⁾ Dimensions in mm
⁽²⁾ Number of stages

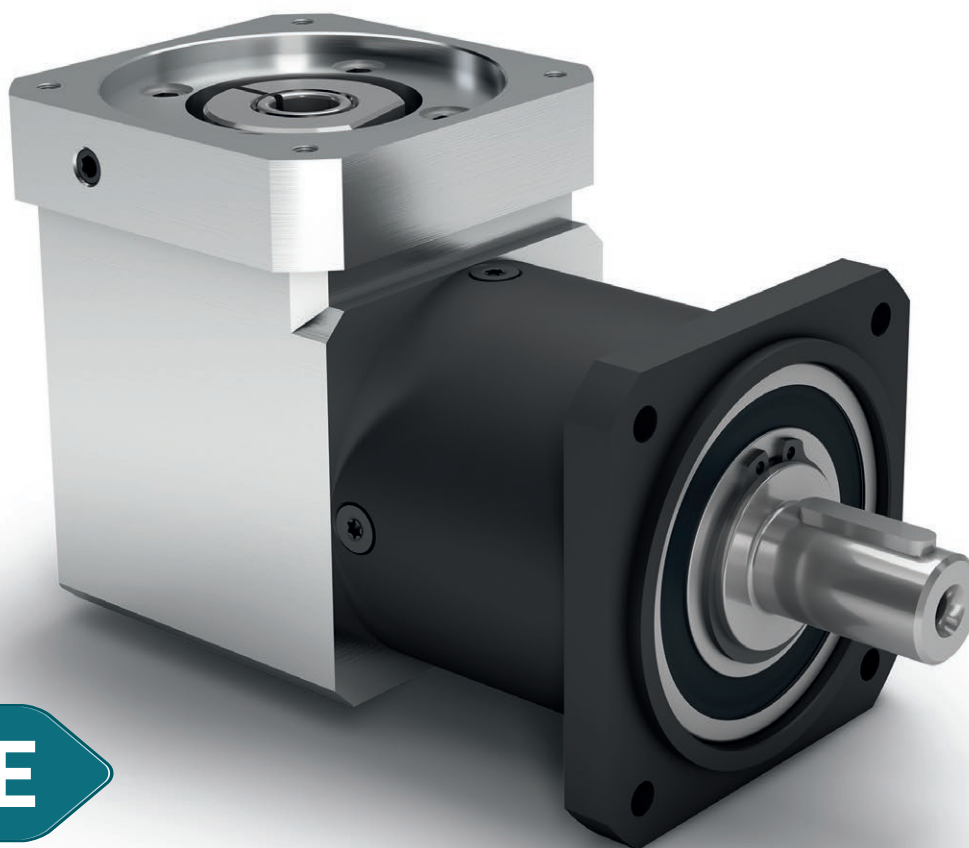

WPLQE

直角行星减速机，带方形通孔输出法兰
安装灵活，适用于承载力很大的
工况中

WPLQE 是一款配有正方形输出法兰的直角减速机。因此，其安装十分便捷，可多面使用，而且由于配有较大规格的深沟球轴承，还能承受较高的径向力和轴向力。

The right angle planetary gearbox
with universal output flange –
flexible installation options and
for high forces

The **WPLQE** is our right angle gearbox with the square output flange. This makes it particularly easy to install for a wide range of applications, and its large deep groove ball bearings also make it ideal for high radial and axial forces.

- + 输入法兰可适配特殊的电机
- + 终生润滑，因此免维护
- + 旋转方向同向
- + 输出轴样式多样
- + 精确啮合
- + 传动比范围广，从 $i = 3$ 到 $i = 512$

- + Individual adaptation of the input flange to the motor
- + Lifetime lubrication for maintenance-free operation
- + Equidirectional rotation
- + Wide range of output shaft designs
- + Precise gearing
- + Wide range of ratios $i = 3$ to $i = 512$

1 正方形输出法兰

WPLQE 无需其他中间法兰就能直接使用螺栓拧紧固定在机器上。带通孔的输出法兰使得维护方便可靠，安装简单。

2 经优化的深沟球轴承

在 **WPLQE** 上，输出元件可直接安装在输出轴上——在不影响性能的情况下节约了时间和成本。由于输出端配有较大规格的深沟球轴承，这款直角减速机还能承受较高的径向力和轴向力。

3 安装时灵活度极高

一款集各种优点于一身的减速机：**WPLQE** 已经过终生润滑，且由于安装形式多变，所以其灵活性也是无与伦比的。

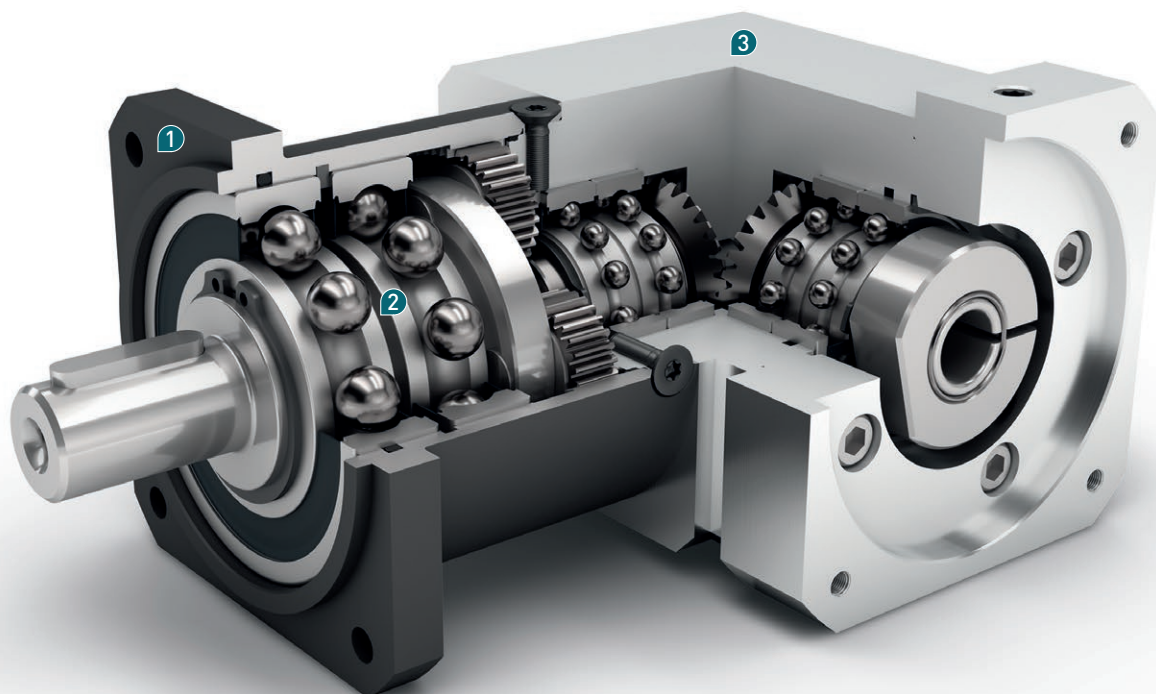

1 Square output flange

The **WPLQE** can be bolted directly to the machine without the need for additional intermediate flanges.

The output flange with through holes safeguard the ease, reliability, and full accessibility of the installation.

2 Optimized ball bearings

Install your drive elements directly on the output shaft at the **WPLQE** – this saves time and money without compromising performance. Thanks to its large deep groove ball bearings at the output, this right angle gearbox can also absorb large radial and axial forces.

3 Highest installation flexibility

You will get the most out of your gearbox: The **WPLQE** has lifetime lubrication and can be installed virtually anywhere for maximum flexibility.

Code	减速机参数	Gearbox characteristics			WPLQE060	WPLQE080	WPLQE120	z ⁽¹⁾
	使用寿命	Service life	t _L	h	20.000			
	T _{2N} × 0.88 时的使用寿命	Service life at T _{2N} × 0.88			30.000			
	满载时效率 ⁽²⁾	Efficiency at full load ⁽²⁾	η	%	95			1
					94			2
					88			3
	最低工作温度	Min. operating temperature	T _{min}	°C	-25			
	最高工作温度	Max. operating temperature	T _{max}		90			
	防护等级	Protection class			IP 54			
S	标准润滑	Standard lubrication			润滑脂 / Grease			
F	食品级润滑	Food grade lubrication			润滑脂 / Grease			
L	低温润滑 ⁽³⁾	Low temperature lubrication ⁽³⁾			润滑脂 / Grease			
	安装位置	Installation position			任意 / Any			
S	标准回程间隙	Standard backlash	j _t	arcmin	< 16	< 13	< 11	1
					< 18	< 15	< 13	2
					< 21	< 17	< 15	3
	抗扭刚度 ⁽²⁾	Torsional stiffness ⁽²⁾	c _g	Nm / arcmin	1,6 - 2,1	4,7 - 6,3	10,1 - 13,6	1
					1,7 - 2,1	5,1 - 6,3	11,0 - 13,6	2
					1,6 - 2,1	4,9 - 6,3	10,5 - 13,6	3
	减速机重量	Gearbox weight	m _G	kg	1,9	5,5	12,6	1
					2,1	6,1	14,6	2
					2,3	6,6	16,6	3
S	标准的箱体表面	Standard surface			箱体：钢 - 氮碳共渗和后氧化处理 (黑色) Housing: Steel - nitrocarburized and post-oxidized (black)			
	运行噪音 ⁽⁴⁾	Running noise ⁽⁴⁾	Q _g	dB(A)	70	73	75	
	基于减速机输入法兰的最大弯矩 ⁽⁵⁾	Max. bending moment based on the gearbox input flange ⁽⁵⁾	M _b	Nm	5	10,5	26	
	电机法兰精度	Motor flange precision			DIN 42955-N			

输出轴载荷	Output shaft loads			WPLQE060	WPLQE080	WPLQE120	z ⁽¹⁾
20,000 h 的径向力 ⁽⁶⁾⁽⁷⁾	Radial force for 20,000 h ⁽⁶⁾⁽⁷⁾	F _{r20.000h}	N	900	2050	2950	
20,000 h 的轴向力 ⁽⁶⁾⁽⁷⁾	Axial force for 20,000 h ⁽⁶⁾⁽⁷⁾	F _{a20.000h}		1000	2500	2500	
30,000 h 的径向力 ⁽⁶⁾⁽⁷⁾	Radial force for 30,000 h ⁽⁶⁾⁽⁷⁾	F _{r30.000h}		700	1700	2400	
30,000 h 的轴向力 ⁽⁶⁾⁽⁷⁾	Axial force for 30,000 h ⁽⁶⁾⁽⁷⁾	F _{a30.000h}		800	2000	2100	
静态径向力 ⁽⁷⁾⁽⁸⁾	Static radial force ⁽⁷⁾⁽⁸⁾	F _{r Stat}		1500	2500	4000	
静态轴向力 ⁽⁷⁾⁽⁸⁾	Static axial force ⁽⁷⁾⁽⁸⁾	F _{a Stat}		1950	3800	3800	
20,000 h 倾斜力矩 ⁽⁶⁾⁽⁸⁾	Tilting moment for 20,000 h ⁽⁶⁾⁽⁸⁾	M _{K20.000h}	Nm	37	101	232	
30,000 h 倾斜力矩 ⁽⁶⁾⁽⁸⁾	Tilting moment for 30,000 h ⁽⁶⁾⁽⁸⁾	M _{K30.000h}		29	84	188	

转动惯量	Moment of inertia			WPLQE060	WPLQE080	WPLQE120	z ⁽¹⁾
转动惯量 ⁽²⁾	Mass moment of inertia ⁽²⁾	J	kgcm ²	0,223 - 0,390	0,928 - 1,538	1,852 - 3,235	1
				0,223 - 0,379	0,932 - 1,438	1,919 - 3,400	2
				0,223 - 0,240	0,931 - 1,368	1,919 - 3,175	3

(1) 减速机级数
 (2) 传动比相关的数值可在 Tec Data Finder 中检索 - www.neugart.com
 (3) T_{min} = -40°C. 理想运行温度最高为 50°C
 (4) 距离减速机 1 m 时; 在输入转速为 n₁=3000 min⁻¹ 且无负荷时测得; i=5
 (5) 最大发动机重量* (单位: kg) = 0.2 × M_b / 发动机长度 (单位: m)
 * 发动机重量对称分布
 * 水平和固定的安装位置
 (6) 数据以 n₂=100 min⁻¹ 的输出轴转速为准。
 (7) 以输出轴中心为准
 (8) 更改 T_{2N}, F_r, F_a 以及周期和轴承使用寿命时, 数值存在偏差 (部分较高)。利用 NCP 针对应用进行专门设计 - www.neugart.com

(1) Number of stages
 (2) The ratio-dependent values can be retrieved in Tec Data Finder - www.neugart.com
 (3) T_{min} = -40°C. Optimal operating temperature max. 50°C
 (4) Sound pressure level from 1 m, measured on input running at n₁=3000 rpm no load; i=5
 (5) Max. motor weight* in kg = 0.2 × M_b / motor length in m
 * with symmetrically distributed motor weight
 * with horizontal and stationary mounting
 (6) These values are based on an output shaft speed of n₂=100 rpm
 (7) Based on center of output shaft
 (8) Other (sometimes higher) values following changes to T_{2N}, F_r, F_a, cycle, and service life of bearing. Application specific configuration with NCP - www.neugart.com

输出扭矩	Output torques			WPLQE060	WPLQE080	WPLQE120	i ⁽¹⁾	z ⁽²⁾
额定输出扭矩 ⁽³⁾⁽⁴⁾	Nominal output torque ⁽³⁾⁽⁴⁾	T _{2N}	Nm	14	40 ⁽⁵⁾	80 ⁽⁵⁾	3	1
				19	53 ⁽⁵⁾	105 ⁽⁵⁾	4	
				24	67 ⁽⁵⁾	130 ⁽⁵⁾	5	
				25	65	135	7	
				18	50	120	8	
				15	38	95	10	
				44 ⁽⁵⁾	130 ⁽⁵⁾	210 ⁽⁵⁾	9	
				44	120 ⁽⁵⁾	260 ⁽⁵⁾	12	2
				44	110	230	15	
				44	120	260	16	
				44	120	260	20	
				40	110	230	25	
				44	120	260	32	
				40	110	230	40	
				18	50	120	64	3
				44	110	260	60	
				44	120	260	80	
				44	120	260	100	
				44	110	230	120	
				44	120	260	160	
				40	110	230	200	
44	120	260	256					
40	110	230	320					
18	50	120	512					
最大输出扭矩 ⁽⁴⁾⁽⁶⁾	Max. output torque ⁽⁴⁾⁽⁶⁾	T _{2max}	Nm	22	64	128	3	1
				30	85	168	4	
				38	107	208	5	
				40	104	216	7	
				29	80	192	8	
				24	61	152	10	
				70	208	336	9	
				70	192	416	12	2
				70	176	368	15	
				70	192	416	16	
				70	192	416	20	
				64	176	368	25	
				70	192	416	32	
				64	176	368	40	
				29	80	192	64	3
				70	176	416	60	
				70	192	416	80	
				70	192	416	100	
				70	176	368	120	
				70	192	416	160	
				64	176	368	200	
70	192	416	256					
64	176	368	320					
29	80	192	512					

WPLQE

(1) 传动比 (i=n₁/n₂)
 (2) 减速机级数
 (3) 利用 NCP 针对应用进行专门设计 – www.neugart.com
 (4) 平键 (代码 „A”)时的数值: 针对交变载荷
 (5) T_{2N} 作用时 寿命不是10,000 h
 (6) 允许输出轴转动30,000转; 参见第 128 页

(1) Ratios (i=n₁/n₂)
 (2) Number of stages
 (3) Application specific configuration with NCP – www.neugart.com
 (4) Values for feather key (code “A”): for repeated load
 (5) Different service life: 10,000 h at T_{2N}
 (6) 30,000 rotations of the output shaft permitted; see page 129

输出扭矩	Output torques			WPLQE060	WPLQE080	WPLQE120	i ⁽¹⁾	z ⁽²⁾
急停扭矩 ⁽³⁾	Emergency stop torque ⁽³⁾	T _{2Stop}	Nm	66	180	360	3	1
				86	240	474	4	
				80	220	500	5	
				80	178	340	7	
				80	190	380	8	
				70	170	430	10	
				88	260	500	9	2
				88	240	520	12	
				88	220	500	15	
				88	240	520	16	
				88	240	520	20	
				80	220	500	25	
				88	240	520	32	3
				80	220	500	40	
				80	190	380	64	
				88	220	520	60	
				88	240	520	80	
				88	240	520	100	
				88	220	500	120	
				88	240	520	160	
				80	220	500	200	
				88	240	520	256	
				80	220	500	320	
				80	190	380	512	

输入转速	Input speeds			WPLQE060	WPLQE080	WPLQE120	i ⁽¹⁾	z ⁽²⁾
T _{2N} 和 S1 时的平均热输入转速 ⁽⁴⁾⁽⁵⁾	Average thermal input speed at T _{2N} and S1 ⁽⁴⁾⁽⁵⁾	n _{1N}	min ⁻¹	4500 ⁽⁶⁾	3100 ⁽⁶⁾	2850 ⁽⁶⁾	3	1
				4500 ⁽⁶⁾	3250 ⁽⁶⁾	2950 ⁽⁶⁾	4	
				4500 ⁽⁶⁾	3350 ⁽⁶⁾	3050 ⁽⁶⁾	5	
				4500	4000 ⁽⁶⁾	3500 ⁽⁶⁾	7	
				4500	4000 ⁽⁶⁾	3500 ⁽⁶⁾	8	
				4500	4000	3500	10	
				4500 ⁽⁶⁾	3150 ⁽⁶⁾	2950 ⁽⁶⁾	9	2
				4500 ⁽⁶⁾	3750 ⁽⁶⁾	3050 ⁽⁶⁾	12	
				4500	4000 ⁽⁶⁾	3500 ⁽⁶⁾	15	
				4500	4000 ⁽⁶⁾	3450 ⁽⁶⁾	16	
				4500	4000 ⁽⁶⁾	3500 ⁽⁶⁾	20	
				4500	4000	3500 ⁽⁶⁾	25	
				4500	4000	3500	32	3
				4500	4000	3500	40	
				4500	4000	3500	64	
				4500	4000	3500	60	
				4500	4000	3500	80	
				4500	4000	3500	100	
				4500	4000	3500	120	
				4500	4000	3500	160	
				4500	4000	3500	200	
				4500	4000	3500	256	
				4500	4000	3500	320	
				4500	4000	3500	512	
最高机械输入转速 ⁽⁴⁾	Max. mechanical input speed ⁽⁴⁾	n _{1Limit}	min ⁻¹	13000	7000	6500		

(1) 传动比 (i=n₁/n₂)

(2) 减速机级数

(3) 允许 1000 次

(4) 利用 NCP 针对应用设计转速 - www.neugart.com

(5) 定义请参见第 128 页

(6) 在 50% T_{2N} 输出和 S1 模式下的平均热传动转速

(1) Ratios (i=n₁/n₂)

(2) Number of stages

(3) Permitted 1000 times

(4) Application-specific speed configurations with NCP - www.neugart.com

(5) See page 129 for the definition

(6) Average thermal input speed at 50% T_{2N} and S1

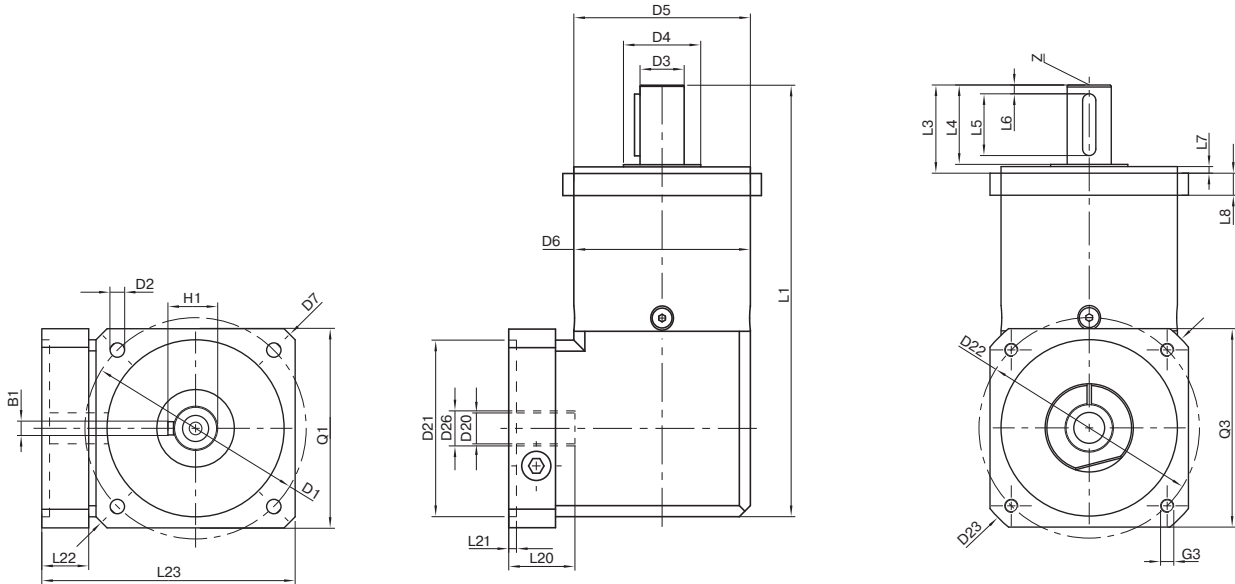

图示为带平键的 WPLQE080 / 1 级 / 附带平键的输出轴 / 19 mm 锁紧系统 / 适配电机法兰 - 2 件式 - 正方形通用法兰 / B5 电机法兰类型
 Drawing corresponds to a WPLQE080 / 1-stage / output shaft with feather key / 19 mm clamping system / motor adaptation - 2-part - square universal flange / B5 flange type motor
 所有其它变量可在 www.neugart.com 下 Tec Data Finder 中检索 - All other variants can be retrieved in Tec Data Finder at www.neugart.com

几何尺寸 ⁽¹⁾	Geometry ⁽¹⁾			WPLQE060	WPLQE080	WPLQE120	z ⁽²⁾	Code
输出端安装孔节圆直径	Pitch circle diameter output	D1		75	100	130		
输出端安装孔直径	Mounting bore output	D2	4x	5,5	6,5	8,5		
输出轴直径	Shaft diameter output	D3	h7	16	20	25		
输出轴轴肩直径	Shaft collar output	D4		20	35	35		
输出端定位凸台直径	Centering diameter output	D5	h7	60	80	110		
箱体直径	Housing diameter	D6		60	80	115		
输出法兰对角线尺寸	Diagonal dimension output	D7		92	116	145		
输出端法兰外方	Flange cross section output	Q1	■	70	90	115		
总长	Total length	L1		152	195,5	274,5	1	
				164,5	213	302,5	2	
				177	230,5	330	3	
输出轴轴长	Shaft length output	L3		32	40	55		
输出端定位凸台深度	Centering depth output	L7		3	3	4		
输出端法兰厚度	Flange thickness output	L8		10	10	15		
最小总高度	Min. overall height	L23		91	115	146		
输入端锁紧系统直径	Clamping system diameter input	D26		更多信息见第 117 页 More information on page 117				
电机轴直径 j6/k6	Motor shaft diameter j6/k6	D20		具体尺寸视电机/减速机法兰而定。 可以在 www.neugart.com 下 Tec Data Finder. 中针对每个电机适配电机特有的输入法兰几何尺寸 The dimensions vary with the motor/gearbox flange. The input flange geometries can be retrieved for each specific motor in Tec Data Finder at www.neugart.com				
最大允许的电机轴长	Max. permis. motor shaft length	L20						
最小允许的电机轴长	Min. permis. motor shaft length							
输入端定位凹槽直径	Centering diameter input	D21						
输入端定位凹槽深度	Centering depth input	L21						
输入端安装孔节圆直径	Pitch circle diameter input	D22						
输入法兰长度	Motor flange length	L22						
输入法兰对角线尺寸	Diagonal dimension input	D23						
安装螺纹 x 深度	Mounting thread x depth	G3	4x					
输入端法兰外方	Flange cross section input	Q3	■					
附带平键的输出轴 (DIN 6885-1)	Output shaft with feather key (DIN 6885-1)			A 5x5x20	A 6x6x28	A 8x7x40		A
平键宽度 (DIN 6885-1)	Feather key width (DIN 6885-1)	B1		5	6	8		
含平键在内的轴高 (DIN 6885-1)	Shaft height including feather key (DIN 6885-1)	H1		18	22,5	28		
到轴肩的距离	Shaft length from shoulder	L4		28	36	50		
平键长度	Feather key length	L5		20	28	40		
到轴端的距离	Distance from shaft end	L6		4	4	5		
中心孔 (DIN 332, DR 形)	Center hole (DIN 332, type DR)	Z		M5x12,5	M6x16	M10x22		
光滑输出轴	Smooth output shaft							B
到轴肩的距离	Shaft length from shoulder	L4		28	36	50		

⁽¹⁾ 所有的尺寸单位为mm
⁽²⁾ 减速机级数

⁽¹⁾ Dimensions in mm
⁽²⁾ Number of stages

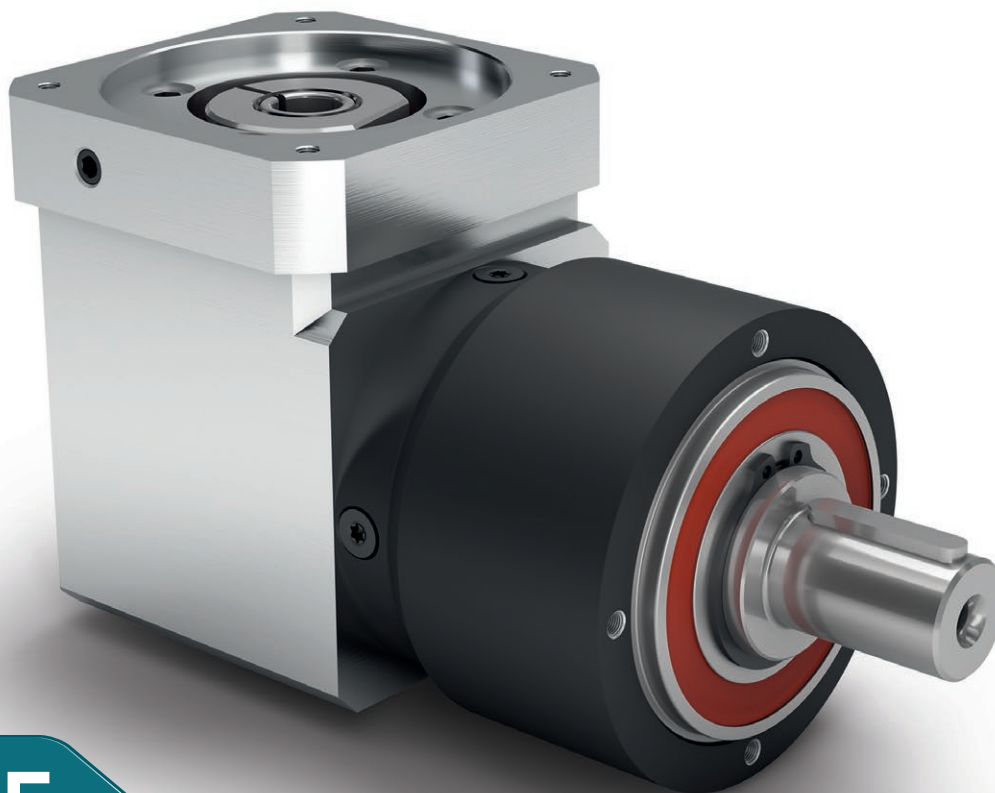

WPLPE

经济型直角行星减速机，适用于承载力很大的工况中
可进行多面安装，终生润滑，免维护

这款 **WPLPE** 是我们在经济型产品领域的智能型直角式解决方案：节省空间，性能强劲，且价格十分合理。驱动元件可直接安装在输出轴上，在实际应用中获得最佳灵活度。

The economical right angle planetary gearbox for particularly high forces – flexible installation options and lifetime lubrication

The **WPLPE** is the smart right angle solution from our Economy Line: Space-saving, and yet powerful at an attractive price. You install your drive elements directly on the output shaft and extract the maximum flexibility from your application.

- + 输入法兰可适配特殊的电机
- + 终生润滑，因此免维护
- + 旋转方向同向
- + 输出轴样式多样
- + 精确啮合
- + 可节省空间的紧凑式直角减速机

- + Individual adaptation of the input flange to the motor
- + Lifetime lubrication for maintenance-free operation
- + Equidirectional rotation
- + Wide range of output shaft designs
- + Precise gearing
- + Compact, space saving right angle stage

① 适用于高径向力和轴向力的情况

由于配有大规格的深沟球轴承，**WPLPE** 还能承受较高的径向力和轴向力。无需额外的轴承组件，其驱动元件可直接安装在输出轴上。

② 无可比拟的性价比

WPLPE 在价格十分合理的情况下性能也非常出众。这款直角行星减速机性能强劲，适用于多种应用领域。

③ 可多面安装且运行可靠

即使空间受限，也能表现出色。**WPLPE** 的紧凑型结构型式使得其可进行多面安装。此款减速机已经过终生润滑，能够发挥出最佳性能。

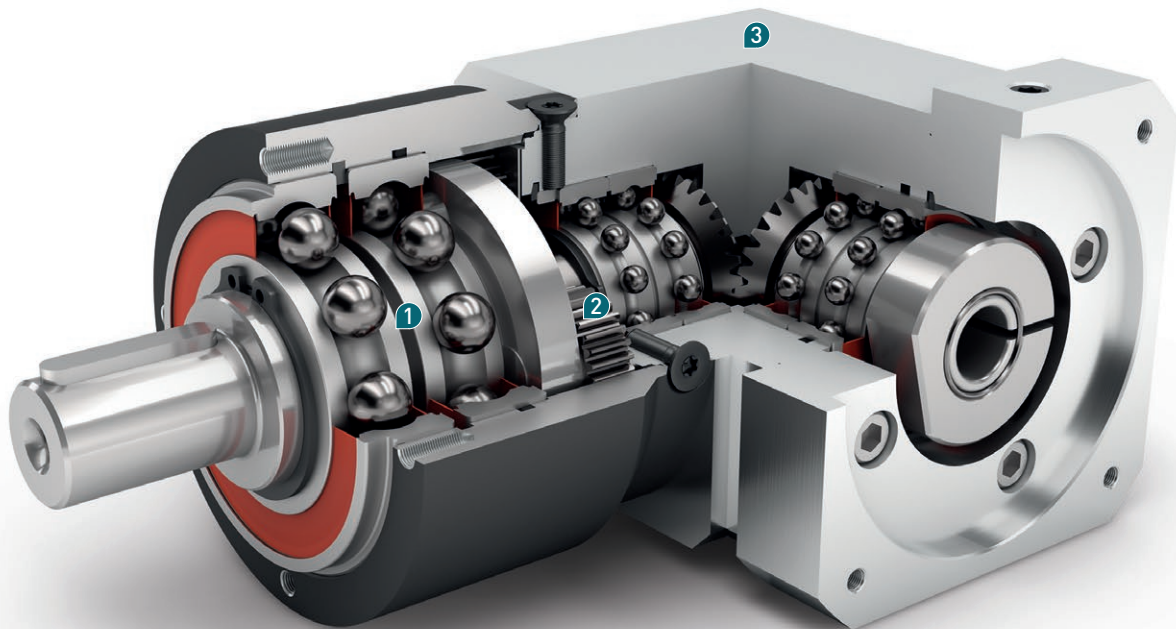

① Suitable for high radial and axial forces

Thanks to its large deep groove ball bearings, the **WPLPE** can absorb even high radial and axial forces. Your drive elements can therefore be installed directly on the output shaft without the need for additional bearing components.

② Unbeatable price-performance ratio

The **WPLPE** delivers the full performance at an attractive price. You benefit from a powerful right angle planetary gearbox for the most diverse range of applications.

③ Flexible installation options and reliability

Great performance, even in restricted spaces. Especially because of its compact design, the **WPLPE** can be installed virtually anywhere. It has lifetime lubrication and is therefore destined for optimal performance.

Code	减速机参数	Gearbox characteristics			WPLPE050	WPLPE070	WPLPE090	WPLPE120	z ⁽¹⁾
	使用寿命	Service life	t _L	h	20.000				
	T _{2N} × 0.88 时的使用寿命	Service life at T _{2N} × 0.88			30.000				
	满载时效率 ⁽²⁾	Efficiency at full load ⁽²⁾	η	%	95				
					94				
	最低工作温度	Min. operating temperature	T _{min}	°C	-25				
	最高工作温度	Max. operating temperature	T _{max}		90				
	防护等级	Protection class	IP 54						
S	标准润滑	Standard lubrication	润滑脂 / Grease						
F	食品级润滑	Food grade lubrication	润滑脂 / Grease						
L	低温润滑 ⁽³⁾	Low temperature lubrication ⁽³⁾	润滑脂 / Grease						
	安装位置	Installation position	任意 / Any						
S	标准回程间隙	Standard backlash	j _t	arcmin	< 21	< 16	< 13	< 11	1
					< 25	< 18	< 15	< 13	2
	抗扭刚度 ⁽²⁾	Torsional stiffness ⁽²⁾	c _G	Nm / arcmin	0,7 - 0,9	2,4 - 3,2	6,8 - 9,1	19,0 - 25,5	1
					0,7 - 0,9	2,4 - 3,2	6,9 - 9,1	19,5 - 25,5	2
	减速机重量	Gearbox weight	m _G	kg	0,85	2,3	5,3	13,5	1
					1,05	2,6	6,1	15,7	2
S	标准的箱体表面	Standard surface	箱体: 钢 - 氮碳共渗和后氧化处理 (黑色) Housing: Steel - nitrocarburized and post-oxidized (black)						
	运行噪音 ⁽⁴⁾	Running noise ⁽⁴⁾	Q _g	dB(A)	68	70	73	75	
	基于减速机输入法兰的最大弯矩 ⁽⁵⁾	Max. bending moment based on the gearbox input flange ⁽⁵⁾	M _b	Nm	2	5	10,5	26	
	电机法兰精度	Motor flange precision	DIN 42955-N						

输出轴载荷	Output shaft loads			WPLPE050	WPLPE070	WPLPE090	WPLPE120	z ⁽¹⁾
20,000 h 的径向力 ⁽⁶⁾⁽⁷⁾	Radial force for 20,000 h ⁽⁶⁾⁽⁷⁾	F _{r20.000h}	N	800	1050	1900	2500	
20,000 h 的轴向力 ⁽⁶⁾⁽⁷⁾	Axial force for 20,000 h ⁽⁶⁾⁽⁷⁾	F _{a20.000h}		1000	1350	2000	4000	
30,000 h 的径向力 ⁽⁶⁾⁽⁷⁾	Radial force for 30,000 h ⁽⁶⁾⁽⁷⁾	F _{r30.000h}		700	900	1700	2150	
30,000 h 的轴向力 ⁽⁶⁾⁽⁷⁾	Axial force for 30,000 h ⁽⁶⁾⁽⁷⁾	F _{a30.000h}		800	1000	1500	3000	
静态径向力 ⁽⁷⁾⁽⁸⁾	Static radial force ⁽⁷⁾⁽⁸⁾	F _{r Stat}		1300	1650	3100	4000	
静态轴向力 ⁽⁷⁾⁽⁸⁾	Static axial force ⁽⁷⁾⁽⁸⁾	F _{a Stat}		1000	2100	3800	5900	
20,000 h 倾斜力矩 ⁽⁶⁾⁽⁸⁾	Tilting moment for 20,000 h ⁽⁶⁾⁽⁸⁾	M _{K20.000h}	Nm	26	42	99	168	
30,000 h 倾斜力矩 ⁽⁶⁾⁽⁸⁾	Tilting moment for 30,000 h ⁽⁶⁾⁽⁸⁾	M _{K30.000h}		22	36	89	144	

转动惯量	Moment of inertia			WPLPE050	WPLPE070	WPLPE090	WPLPE120	z ⁽¹⁾
转动惯量 ⁽²⁾	Mass moment of inertia ⁽²⁾	J	kgcm ²	0,032 - 0,052	0,218 - 0,335	0,932 - 1,545	1,890 - 3,612	1
				0,032 - 0,050	0,218 - 0,335	0,914 - 1,448	1,850 - 3,446	2

(1) 减速机级数
 (2) 传动比相关的数值可在 Tec Data Finder 中检索 - www.neugart.com
 (3) T_{min} = -40°C. 理想运行温度最高为 50°C
 (4) 距离减速机 1 m 时; 在输入转速为 n₁=3000 min⁻¹ 且无负荷时测得; i=5
 (5) 最大发动机重量* (单位: kg) = 0.2 × M_b / 发动机长度 (单位: m)
 * 发动机重量对称分布
 * 水平和固定的安装位置
 (6) 数据以 n₂=100 min⁻¹ 的输出轴转速为准。
 (7) 以输出轴中心为准
 (8) 更改 T_{2N}, F_r, F_a 以及周期和轴承使用寿命时, 数值存在偏差 (部分较高)。利用 NCP 针对应用进行专门设计 - www.neugart.com

(1) Number of stages
 (2) The ratio-dependent values can be retrieved in Tec Data Finder - www.neugart.com
 (3) T_{min} = -40°C. Optimal operating temperature max. 50°C
 (4) Sound pressure level from 1 m, measured on input running at n₁=3000 rpm no load; i=5
 (5) Max. motor weight* in kg = 0.2 × M_b / motor length in m
 * with symmetrically distributed motor weight
 * with horizontal and stationary mounting
 (6) These values are based on an output shaft speed of n₂=100 rpm
 (7) Based on center of output shaft
 (8) Other (sometimes higher) values following changes to T_{2N}, F_r, F_a, cycle, and service life of bearing. Application specific configuration with NCP - www.neugart.com

输出扭矩	Output torques			WPLPE050	WPLPE070	WPLPE090	WPLPE120	i ⁽¹⁾	z ⁽²⁾
额定输出扭矩 ⁽³⁾⁽⁴⁾	Nominal output torque ⁽³⁾⁽⁴⁾	T _{2N}	Nm	4,5	14	40 ⁽⁵⁾	80 ⁽⁵⁾	3	1
				6	19	53 ⁽⁵⁾	105 ⁽⁵⁾	4	
				7,5	24	67 ⁽⁵⁾	130 ⁽⁵⁾	5	
				8,5	25	65	135	7	
				6	18	50	120	8	
				5	15	38	95	10	
				12	33	97	157	9	2
				15	33	90	195	12	
				13	33	82	172	15	
				15	33	90	195	16	
				15	33	90	195	20	
				13	30	82	172	25	
				15	33	90	195	32	2
				13	30	82	172	40	
				7,5	18	50	120	64	
				5	15	38	95	100	
7	22	64	128	3	1				
10	30	85	168	4					
12	38	107	208	5					
13,5	40	104	216	7					
10	29	80	192	8					
8	24	61	152	10					
19	53	155	251	9	2				
24	53	144	312	12					
21	53	131	275	15					
24	53	144	312	16					
24	53	144	312	20					
21	48	131	275	25					
24	53	144	312	32	2				
21	48	131	275	40					
12	29	80	192	64					
8	24	61	152	100					
最大输出扭矩 ⁽⁴⁾⁽⁶⁾	Max. output torque ⁽⁴⁾⁽⁶⁾	T _{2max}	Nm						

WPLPE

⁽¹⁾ 传动比 (i=n₁/n₂)

⁽²⁾ 减速机级数

⁽³⁾ 利用 NCP 针对应用进行专门设计 – www.neugart.com

⁽⁴⁾ 平键 (代码 „A”)时的数值: 针对交变载荷

⁽⁵⁾ T_{2N} 作用时 寿命不是10,000 h

⁽⁶⁾ 允许输出轴转动30,000转; 参见第 128 页

⁽¹⁾ Ratios (i=n₁/n₂)

⁽²⁾ Number of stages

⁽³⁾ Application specific configuration with NCP – www.neugart.com

⁽⁴⁾ Values for feather key (code “A”): for repeated load

⁽⁵⁾ Different service life: 10,000 h at T_{2N}

⁽⁶⁾ 30,000 rotations of the output shaft permitted; see page 129

输出扭矩	Output torques			WPLPE050	WPLPE070	WPLPE090	WPLPE120	i ⁽¹⁾	z ⁽²⁾
急停扭矩 ⁽³⁾	Emergency stop torque ⁽³⁾	T _{2Stop}	Nm	22,5	66	180	360	3	1
				28	86	240	474	4	
				35	80	220	500	5	
				26	80	178	340	7	
				27	80	190	380	8	
				25	70	170	430	10	
				33	88	260	500	9	2
				40	88	240	520	12	
				36	88	220	500	15	
				40	88	240	520	16	
				40	88	240	520	20	
				36	80	220	500	25	
				40	88	240	520	32	
				36	80	220	500	40	
				27	80	190	380	64	
				27	80	170	430	100	

输入转速	Input speeds			WPLPE050	WPLPE070	WPLPE090	WPLPE120	i ⁽¹⁾	z ⁽²⁾					
T _{2N} 和 S1 时的平均热输入转速 ⁽⁴⁾⁽⁵⁾	Average thermal input speed at T _{2N} and S1 ⁽⁴⁾⁽⁵⁾	n _{1N}	min ⁻¹	5000	4200 ⁽⁶⁾	3000 ⁽⁶⁾	2350 ⁽⁶⁾	3	1					
				5000	4500 ⁽⁶⁾	3150 ⁽⁶⁾	2450 ⁽⁶⁾	4						
				5000	4500 ⁽⁶⁾	3250 ⁽⁶⁾	2600 ⁽⁶⁾	5						
				5000	4500 ⁽⁶⁾	3950 ⁽⁶⁾	3100 ⁽⁶⁾	7						
				5000	4500	4000 ⁽⁶⁾	3450 ⁽⁶⁾	8						
				5000	4500	4000	3500 ⁽⁶⁾	10						
				5000	4500 ⁽⁶⁾	3500 ⁽⁶⁾	2950 ⁽⁶⁾	9	2					
				5000	4500	4000 ⁽⁶⁾	3050 ⁽⁶⁾	12						
				5000	4500	4000 ⁽⁶⁾	3450 ⁽⁶⁾	15						
				5000	4500	4000 ⁽⁶⁾	3450 ⁽⁶⁾	16						
				5000	4500	4000 ⁽⁶⁾	3500 ⁽⁶⁾	20						
				5000	4500	4000	3500 ⁽⁶⁾	25						
				5000	4500	4000	3500	32						
				5000	4500	4000	3500	40						
				5000	4500	4000	3500	64						
				5000	4500	4000	3500	100						
				最高机械输入转速 ⁽⁴⁾	Max. mechanical input speed ⁽⁴⁾	n _{1Limit}	min ⁻¹	18000		13000	7000	6500		

⁽¹⁾ 传动比 (i=n₁/n₂)

⁽²⁾ 减速机级数

⁽³⁾ 允许 1000 次

⁽⁴⁾ 利用 NCP 针对应用设计转速 - www.neugart.com

⁽⁵⁾ 定义请参见第 128 页

⁽⁶⁾ 在 50% T_{2N} 输出和 S1 模式下的平均热传动转速

⁽¹⁾ Ratios (i=n₁/n₂)

⁽²⁾ Number of stages

⁽³⁾ Permitted 1000 times

⁽⁴⁾ Application-specific speed configurations with NCP - www.neugart.com

⁽⁵⁾ See page 129 for the definition

⁽⁶⁾ Average thermal input speed at 50% T_{2N} and S1

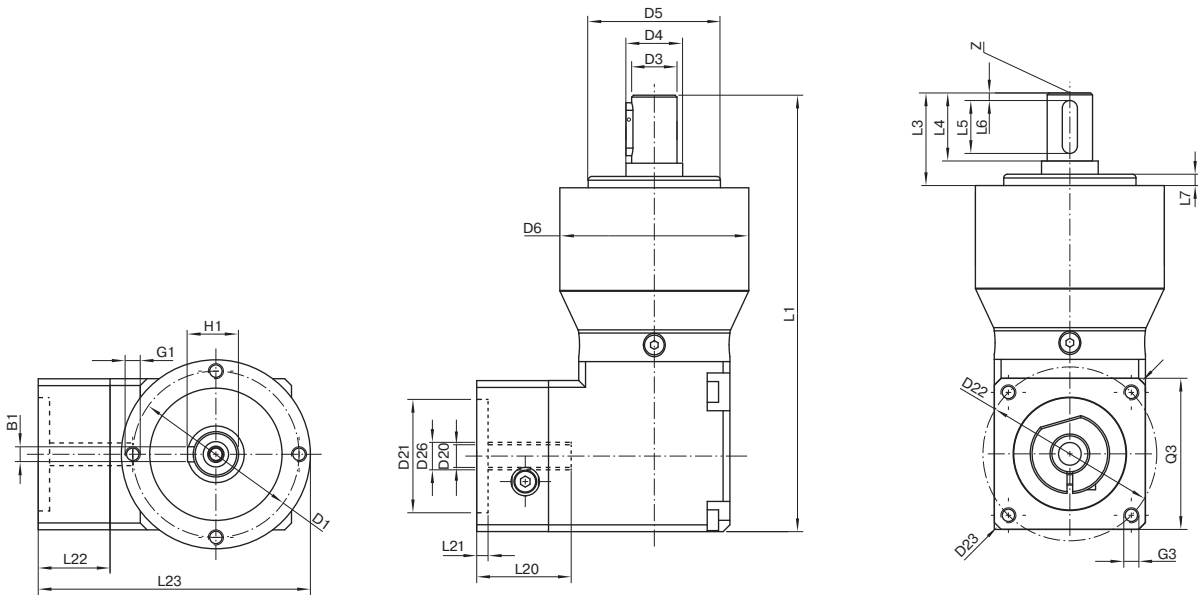

图示为带平键的WPLPE090 / 1级 / 附带平键的输出轴 / 19 mm 锁紧系统 / 适配电机法兰 - 2 件式 - 正方形通用法兰 / B5 电机法兰类型
 Drawing corresponds to a WPLPE090 / 1-stage / output shaft with feather key / 19 mm clamping system / motor adaptation - 2-part - square universal flange / B5 flange type motor
 所有其它变量可在 www.neugart.com 下 Tec Data Finder 中检索 - All other variants can be retrieved in the Tec Data Finder at www.neugart.com

几何尺寸 ⁽¹⁾	Geometry ⁽¹⁾			WPLPE050	WPLPE070	WPLPE090	WPLPE120	z ⁽²⁾	Code
输出端安装孔节圆直径	Pitch circle diameter output	D1		44	62	80	108		
输出轴直径	Shaft diameter output	D3	k7	12	16	22	32		
输出轴轴肩直径	Shaft collar output	D4		15	30	35	50		
输出端定位凸台直径	Centering diameter output	D5	h7	35	52	68	90		
箱体直径	Housing diameter	D6		50	70	90	120		
安装螺纹 x 深度	Mounting thread x depth	G1	4x	M4x8	M5x8	M6x9	M8x20		
总长	Total length	L1		115,5	152,5	197,5	265	1	
				128	165,5	215,5	292,5	2	
输出轴轴长	Shaft length output	L3		24,5	36	46	68		
输出端定位凸台深度	Centering depth output	L7		3	3	4	5		
最小总高度	Min. overall height	L23		67	91	115	148		
输入端锁紧系统直径	Clamping system diameter input	D26		更多信息见第 117 页 More information on page 117					
电机轴直径 j6/k6	Motor shaft diameter j6/k6	D20		具体尺寸视电机/减速机法兰而定。 可以在 www.neugart.com 下 Tec Data Finder 中针对每个电机适配电机特有的输入法兰几何尺寸 The dimensions vary with the motor/gearbox flange. The input flange geometries can be retrieved for each specific motor in Tec Data Finder at www.neugart.com					
最大允许的电机轴长	Max. permis. motor shaft length	L20							
最小允许的电机轴长	Min. permis. motor shaft length								
输入端定位凹槽直径	Centering diameter input	D21							
输入端定位凹槽深度	Centering depth input	L21							
输入端安装孔节圆直径	Pitch circle diameter input	D22							
输入法兰长度	Motor flange length	L22							
输入法兰对角线尺寸	Diagonal dimension input	D23							
安装螺纹 x 深度	Mounting thread x depth	G3	4x						
输入端法兰外方	Flange cross section input	Q3	■						
附带平键的输出轴 (DIN 6885-1)	Output shaft with feather key (DIN 6885-1)			A 4x4x14	A 5x5x25	A 6x6x32	A 10x8x50		
平键宽度 (DIN 6885-1)	Feather key width (DIN 6885-1)	B1		4	5	6	10		A
含平键在内的轴高 (DIN 6885-1)	Shaft height including feather key (DIN 6885-1)	H1		13,5	18	24,5	35		
到轴肩的距离	Shaft length from shoulder	L4		18	28	36	58		
平键长度	Feather key length	L5		14	25	32	50		
到轴端的距离	Distance from shaft end	L6		2	2	2	4		
中心孔 (DIN 332, DR 形)	Center hole (DIN 332, type DR)	Z		M4x10	M5x12,5	M8x19	M12x28		
光滑输出轴	Smooth output shaft								
到轴肩的距离	Shaft length from shoulder	L4		18	28	36	58		B

⁽¹⁾ 所有的尺寸单位为mm
⁽²⁾ 减速机级数

⁽¹⁾ Dimensions in mm
⁽²⁾ Number of stages

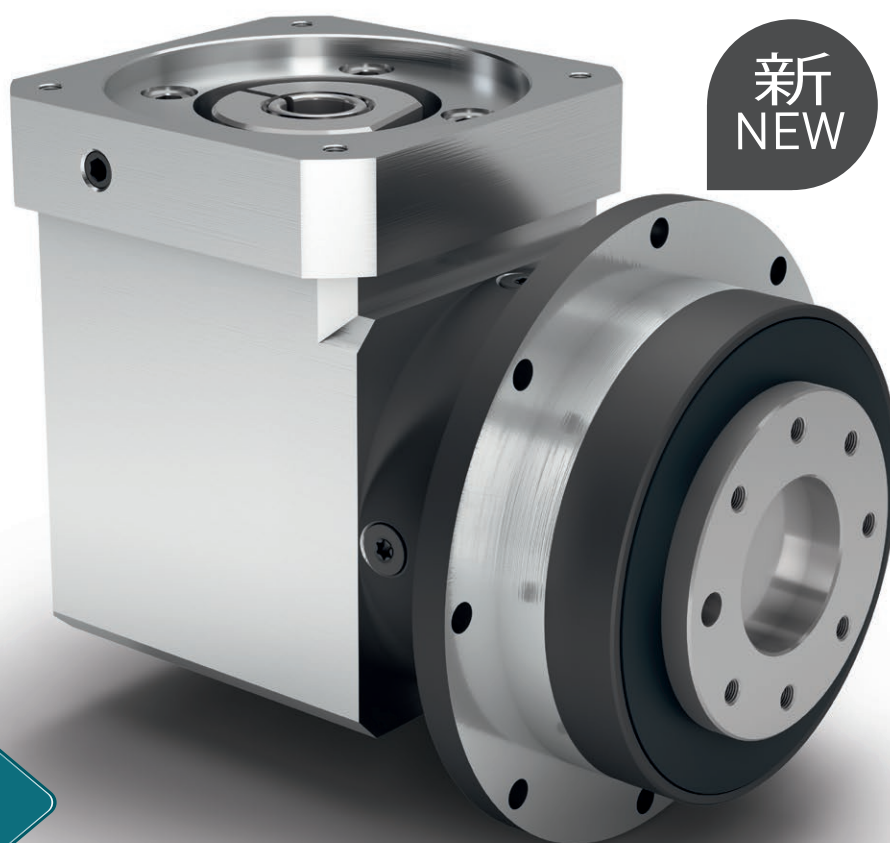

WPLFE

最短的直角行星减速机 配有法兰输出轴 扭转刚度极高

即使面临困境，也要冲破局限，发挥创新思维。**WPLFE** 是一款配有紧凑型法兰输出轴的直角行星减速机。它最多可节省三分之一的空间，且扭转刚度提高了五倍。凭借其标准化的法兰接口，该行星减速机的安装极其简便。内置的定位销孔还为固定时的安全性提供了额外的保障。

The shortest right angle planetary gearbox with flange output shaft and maximum torsional stiffness

Thinking around corners even in tight spaces. The **WPLFE** is our right angle planetary gearbox with compact flange output shaft. You save up to a third of the space and benefit from a torsional stiffness that is five times higher than conventional products. Thanks to its standardized flange interface, it is especially easy to install. The integrated dowel hole provides additional security during fitting.

- + 可安装在任意位置
- + 输入法兰可适配特殊的电机
- + 终生润滑，因此免维护
- + 旋转方向同向
- + 经过优化的轴承设计，性能极佳
- + 精确啮合

- + For any mounting position
- + Individual adaptation of the input flange to the motor
- + Lifetime lubrication for maintenance-free operation
- + Equidirectional rotation
- + Optimized bearing concept for high performance
- + Precise gearing

① 安装简单可靠

WPLFE 标准化 (EN ISO 9409-1) 的法兰接口确保了驱动组件 (如皮带盘、线性元件或转盘给料机等) 的快捷安装。内置的定位销孔还为固定时的安全性提供了额外的保障。

② 超高的扭转刚度, 适用于精密型驱动解决方案

由于法兰输出轴的直径较大, **WPLFE** 的扭转刚度比采用平键的输出轴高出五倍之多。这样一来, 在循环运行和持续运行时, 您的驱动解决方案也能发挥出最佳效果。

③ 安装高度极低, 节省空间

WPLFE 是经济型产品系列中最短的一款直角行星减速机。视规格而定, 其安装所需空间与同类直角减速机产品相比可减少最多 30%。

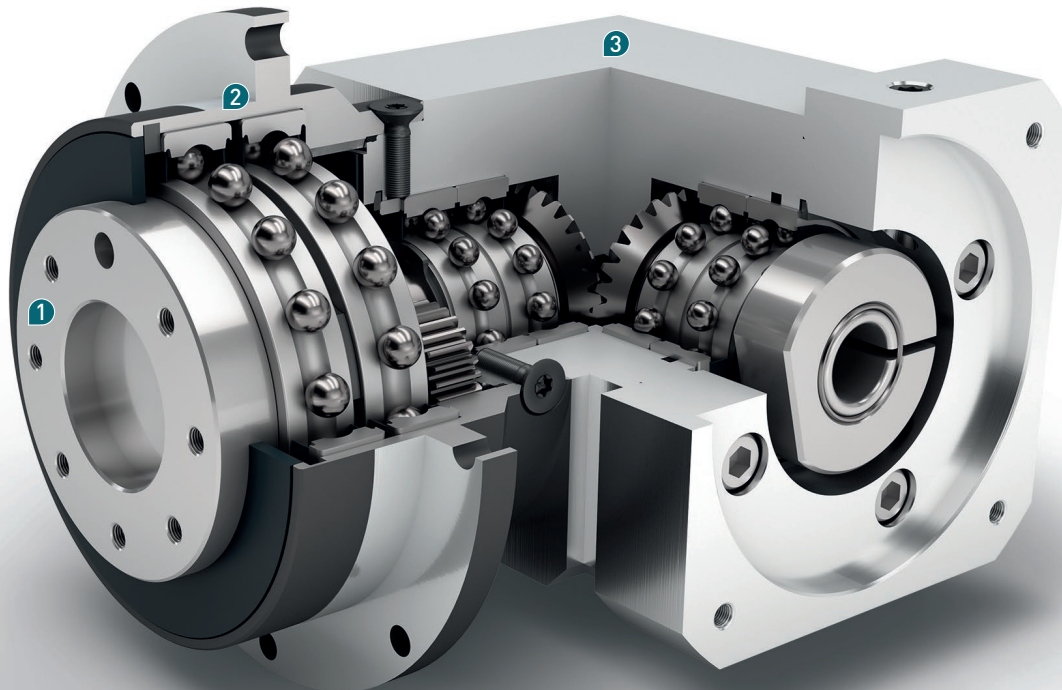

① Easy, reliable, and fast installation

The standardized flange interface of the **WPLFE** (EN ISO 9409-1) guarantees quick and easy mounting of the drive components, such as pulley, linear unit, or turntable. The integrated dowel hole provides additional security during fitting.

② Maximum torsional stiffness for precise drive solutions

The large diameter of the flange output shaft gives the **WPLFE** a torsional stiffness that is five times higher than an output shaft with feather key. You can therefore make the most of your drive solution for intermittent and continuous operation.

③ Space-saving thanks to minimal installation height

The **WPLFE** is the shortest right angle planetary gearbox on the Economy Line. Depending on the frame size, the installation space is up to 30% smaller than comparable right angle gearboxes.

Code	减速机参数	Gearbox characteristics			WPLFE064	WPLFE090	WPLFE110	z ⁽¹⁾
	使用寿命	Service life	t _L	h	20.000			
	T _{2N} × 0.88 时的使用寿命	Service life at T _{2N} × 0.88			30.000			
	满载时效率 ⁽²⁾	Efficiency at full load ⁽²⁾	η	%	94			
					93			
	最低工作温度	Min. operating temperature	T _{min}	°C	-25			
	最高工作温度	Max. operating temperature	T _{max}		90			
	防护等级	Protection class			IP 54			
S	标准润滑	Standard lubrication			润滑脂 / Grease			
F	食品级润滑	Food grade lubrication			润滑脂 / Grease			
L	低温润滑 ⁽³⁾	Low temperature lubrication ⁽³⁾			润滑脂 / Grease			
	安装位置	Installation position			任意 / Any			
S	标准回程间隙	Standard backlash	j _t	arcmin	< 16	< 13	< 11	1
					< 18	< 15	< 13	2
	抗扭刚度 ⁽²⁾	Torsional stiffness ⁽²⁾	c _G	Nm / arcmin	8,9 - 11,9	21,0 - 27,8	52,8 - 71,4	1
					9,1 - 11,9	21,5 - 27,8	53,8 - 70,4	2
	减速机重量	Gearbox weight	m _G	kg	1,9	5,2	13	1
					2,3	5,7	15	2
S	标准的箱体表面	Standard surface			箱体: 钢 - 氮碳共渗和后氧化处理 (黑色) Housing: Steel - nitrocarburized and post-oxidized (black)			
	运行噪音 ⁽⁴⁾	Running noise ⁽⁴⁾	Q _g	dB(A)	70	73	75	
	基于减速机输入法兰的最大弯矩 ⁽⁵⁾	Max. bending moment based on the gearbox input flange ⁽⁵⁾	M _b	Nm	5	10,5	26	
	电机法兰精度	Motor flange precision			DIN 42955-N			

Abtriebswellenbelastungen	Output shaft loads				WPLFE064	WPLFE090	WPLFE110	z ⁽¹⁾
20,000 h 的径向力 ⁽⁶⁾⁽⁷⁾	Radial force for 20,000 h ⁽⁶⁾⁽⁷⁾	F _{r20.000 h}	N		550	1400	2400	
20,000 h 的轴向力 ⁽⁶⁾⁽⁷⁾	Axial force for 20,000 h ⁽⁶⁾⁽⁷⁾	F _{a20.000 h}			1200	3000	3300	
30,000 h 的径向力 ⁽⁶⁾⁽⁷⁾	Radial force for 30,000 h ⁽⁶⁾⁽⁷⁾	F _{r30.000 h}			500	1200	2100	
30,000 h 的轴向力 ⁽⁶⁾⁽⁷⁾	Axial force for 30,000 h ⁽⁶⁾⁽⁷⁾	F _{a30.000 h}			1200	3000	3300	
静态径向力 ⁽⁷⁾⁽⁸⁾	Static radial force ⁽⁷⁾⁽⁸⁾	F _{r Stat}			900	2200	3800	
静态轴向力 ⁽⁷⁾⁽⁸⁾	Static axial force ⁽⁷⁾⁽⁸⁾	F _{a Stat}			1200	3300	5200	
20,000 h 倾斜力矩 ⁽⁶⁾⁽⁸⁾	Tilting moment for 20,000 h ⁽⁶⁾⁽⁸⁾	M _{K20.000 h}	Nm		12	46	109	
30,000 h 倾斜力矩 ⁽⁶⁾⁽⁸⁾	Tilting moment for 30,000 h ⁽⁶⁾⁽⁸⁾	M _{K30.000 h}			11	40	96	

转动惯量	Moment of inertia				WPLFE064	WPLFE090	WPLFE110	z ⁽¹⁾
转动惯量 ⁽²⁾	Mass moment of inertia ⁽²⁾	J	kgcm ²		0,229 - 0,458	0,964 - 1,913	1,955 - 4,272	1
					0,221 - 0,387	0,917 - 1,477	1,850 - 3,515	2

(1) 减速机级数
 (2) 传动比相关的数值可在 Tec Data Finder 中检索 - www.neugart.com
 (3) T_{min} = -40°C. 理想运行温度最高为 50°C
 (4) 距离减速机 1 m 时; 在输入转速为 n₁=3000 min⁻¹ 且无负荷时测得; i=5
 (5) 最大发动机重量* (单位: kg) = 0.2 × M_b / 发动机长度 (单位: m)
 * 发动机重量对称分布
 * 水平和固定的安装位置
 (6) 数据以 n₂=100 min⁻¹ 的输出轴转速为准。
 (7) 基于输出轴末端
 (8) 更改 T_{2N}, F_r, F_a 以及周期和轴承使用寿命时, 数值存在偏差 (部分较高)。利用 NCP 针对应用进行专门设计 - www.neugart.com

(1) Number of stages
 (2) The ratio-dependent values can be retrieved in Tec Data Finder - www.neugart.com
 (3) T_{min} = -40°C. Optimal operating temperature max. 50°C
 (4) Sound pressure level from 1 m, measured on input running at n₁=3000 rpm no load; i=5
 (5) Max. motor weight* in kg = 0.2 × M_b / motor length in m
 * with symmetrically distributed motor weight
 * with horizontal and stationary mounting
 (6) These values are based on an output shaft speed of n₂=100 rpm
 (7) Based on the end of the output shaft
 (8) Other (sometimes higher) values following changes to T_{2N}, F_r, F_a, cycle, and service life of bearing. Application specific configuration with NCP - www.neugart.com

输出扭矩	Output torques			WPLFE064	WPLFE090	WPLFE110	$i^{(1)}$	$z^{(2)}$
额定输出扭矩 ⁽³⁾	Nominal output torque ⁽³⁾	T_{2N}	Nm	14	40 ⁽⁴⁾	80 ⁽⁴⁾	3	1
				19	53 ⁽⁴⁾	105 ⁽⁴⁾	4	
				24	67 ⁽⁴⁾	130 ⁽⁴⁾	5	
				25	65	135	7	
				18	50	120	8	
				15	38	95	10	
				44 ⁽⁴⁾	130 ⁽⁴⁾	210 ⁽⁴⁾	9	2
				44	120 ⁽⁴⁾	260 ⁽⁴⁾	12	
				44	110	230	15	
				44	120	260	16	
				44	120	260	20	
				40	110	230	25	
				44	120	260	32	
				40	110	230	40	
				18	50	120	64	
				15	38	95	100	
				最大输出扭矩 ⁽⁵⁾	Max. output torque ⁽⁵⁾	T_{2max}	Nm	
30	85	168	4					
38	107	208	5					
40	104	216	7					
29	80	192	8					
24	61	152	10					
70	208	336	9					2
70	192	416	12					
70	176	368	15					
70	192	416	16					
70	192	416	20					
64	176	368	25					
70	192	416	32					
64	176	368	40					
29	80	192	64					
24	61	152	100					

⁽¹⁾ 传动比 ($i=n_1/n_2$)⁽²⁾ 减速机级数⁽³⁾ 利用 NCP 针对应用进行专门设计 – www.neugart.com⁽⁴⁾ T_{2N} 作用时 寿命不是10,000 h⁽⁵⁾ 允许输出轴转动30,000转; 参见第 128 页⁽¹⁾ Ratios ($i=n_1/n_2$)⁽²⁾ Number of stages⁽³⁾ Application specific configuration with NCP – www.neugart.com⁽⁴⁾ Different service life: 10,000 h at T_{2N} ⁽⁵⁾ 30,000 rotations of the output shaft permitted; see page 129

输出扭矩	Output torques			WPLFE064	WPLFE090	WPLFE110	i ⁽¹⁾	z ⁽²⁾
急停扭矩 ⁽³⁾	Emergency stop torque ⁽³⁾	T _{2Stop}	Nm	66	180	360	3	1
				86	240	474	4	
				80	220	500	5	
				80	178	340	7	
				80	190	380	8	
				70	170	430	10	
				88	260	500	9	2
				88	240	520	12	
				88	220	500	15	
				88	240	520	16	
				88	240	520	20	
				80	220	500	25	
				88	240	520	32	
				80	220	500	40	
				80	190	380	64	
				80	200	430	100	

输入转速	Input speeds			WPLFE064	WPLFE090	WPLFE110	i ⁽¹⁾	z ⁽²⁾
T _{2N} 和 S1 时的平均热输入转速 ⁽⁴⁾⁽⁵⁾	Average thermal input speed at T _{2N} and S1 ⁽⁴⁾⁽⁵⁾	n _{1N}	min ⁻¹	4000 ⁽⁶⁾	2800 ⁽⁶⁾	2200 ⁽⁶⁾	3	1
				4400 ⁽⁶⁾	3000 ⁽⁶⁾	2400 ⁽⁶⁾	4	
				4500 ⁽⁶⁾	3200 ⁽⁶⁾	2600 ⁽⁶⁾	5	
				4500 ⁽⁶⁾	4000 ⁽⁶⁾	3000 ⁽⁶⁾	7	
				4500	4000 ⁽⁶⁾	3300 ⁽⁶⁾	8	
				4500	4000	3500 ⁽⁶⁾	10	
				4300 ⁽⁶⁾	2900 ⁽⁶⁾	2400 ⁽⁶⁾	9	2
				4500 ⁽⁶⁾	3400 ⁽⁶⁾	2600 ⁽⁶⁾	12	
				4500 ⁽⁶⁾	3800 ⁽⁶⁾	3100 ⁽⁶⁾	15	
				4500 ⁽⁶⁾	3800 ⁽⁶⁾	3000 ⁽⁶⁾	16	
				4500	4000 ⁽⁶⁾	3400 ⁽⁶⁾	20	
				4500	4000 ⁽⁶⁾	3500 ⁽⁶⁾	25	
				4500	4000	3500 ⁽⁶⁾	32	
				4500	4000	3500	40	
				4500	4000	3500	64	
				4500	4000	3500	100	
				最高机械输入转速 ⁽⁴⁾	Max. mechanical input speed ⁽⁴⁾	n _{1Limit}	min ⁻¹	

⁽¹⁾ 传动比 (i=n₁/n₂)

⁽²⁾ 减速机级数

⁽³⁾ 允许 1000 次

⁽⁴⁾ 利用 NCP 针对应用设计转速 - www.neugart.com

⁽⁵⁾ 定义请参见第 128 页

⁽⁶⁾ 在 50% T_{2N} 输出和 S1 模式下的平均热传动转速

⁽¹⁾ Ratios (i=n₁/n₂)

⁽²⁾ Number of stages

⁽³⁾ Permitted 1000 times

⁽⁴⁾ Application-specific speed configurations with NCP - www.neugart.com

⁽⁵⁾ See page 129 for the definition

⁽⁶⁾ Average thermal input speed at 50% T_{2N} and S1

WPLFE064
WPLFE090

WPLFE110

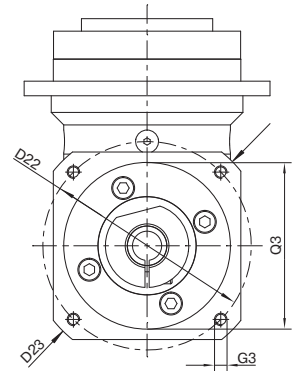
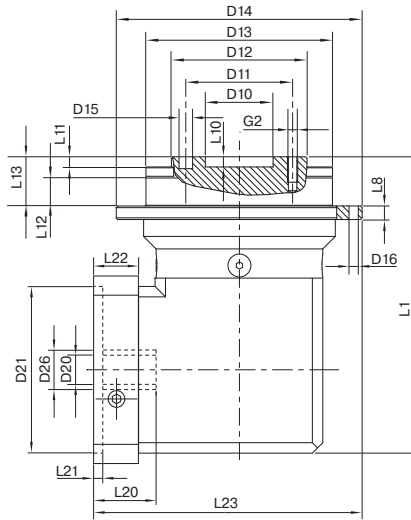
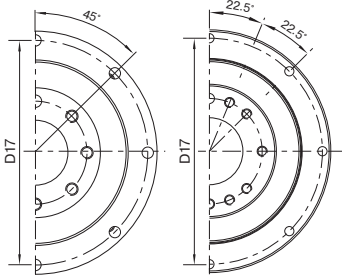

图示为带平键的 WPLFE090 / 1 级 / 带有配合销孔的法兰输出轴 / 19 mm 锁紧系统 / 适配电机法兰 - 2 件式 - 正方形通用法兰 / B5 电机法兰类型

Drawing corresponds to a WPLFE090 / 1-stage / flange output shaft with dowel hole / 19 mm clamping system / motor adaptation - 2-part - square universal flange / B5 flange type motor
所有其它变量可在 www.neugart.com 下 Tec Data Finder 中检索 - All other variants can be retrieved in the Tec Data Finder at www.neugart.com

几何尺寸 ⁽¹⁾	Geometry ⁽¹⁾			WPLFE064	WPLFE090	WPLFE110	z ⁽²⁾	Code
输出端定位凹槽直径	Centering diameter output shaft	D10	H7	20	31,5	40		
输出端安装孔节圆直径	Pitch circle Ø output shaft	D11		31,5	50	63		
输出轴定位凸台直径	Centering diameter output shaft	D12	h7	40	63	80		
输出法兰定位凸台直径	Centering Ø output flange	D13		64	90	110		
输出法兰直径	Flange diameter output	D14		86	118	145		
输出端安装孔直径	Mounting bore output	D16		4,5 8x45°	5,5 8x45°	5,5 8x45°		
输出法兰安装孔节圆直径	Pitch circle Ø output flange	D17		79	109	135		
总长	Total length	L1		110	149	198,5	1	
				122,5	165,5	225,5	2	
输出端法兰厚度	Flange thickness output	L8		4	7	8		
输出轴定位凸台深度	Centering depth output shaft	L10		4	6	6		
		L11		3	6	6		
输出法兰定位凸台深度	Centering depth output flange	L12		7,5	10,5	10,5		
输出法兰长度	Output flange length	L13		19,5	30,0	29,0		
最小总高度	Min. overall height	L23		99	129	161		
输入端锁紧系统直径	Clamping system diameter input	D26		更多信息见第 117 页 More information on page 117				
电机轴直径 j6/k6	Motor shaft diameter j6/k6	D20		具体尺寸视电机/减速机法兰而定。 可以在 www.neugart.com 下 Tec Data Finder. 中针对每个电机适配电机特有的输入法兰几何尺寸 The dimensions vary with the motor/gearbox flange. The input flange geometries can be retrieved for each specific motor in Tec Data Finder at www.neugart.com				
最大允许的电机轴长	Max. permis. motor shaft length	L20						
最小允许的电机轴长	Min. permis. motor shaft length							
输入端定位凹槽直径	Centering diameter input	D21						
输入端定位凹槽深度	Centering depth input	L21						
输入端安装孔节圆直径	Pitch circle diameter input	D22						
输入法兰长度	Motor flange length	L22						
输入法兰对角线尺寸	Diagonal dimension input	D23						
安装螺纹 x 深度	Mounting thread x depth	G3	4x					
输入端法兰外方	Flange cross section input	Q3	■					
带有配合销孔的法兰输出轴 (EN ISO 9409-1)	Flange output shaft with dowel hole (EN ISO 9409-1)							
配合销孔 x 深度	Dowel hole x depth	D15	H7	5x6	6x7	6x7		E
数量 x 螺纹 x 深度	Number x thread x depth	G2		7 x M5x7	7 x M6x10	11 x M6x12		

⁽¹⁾ 所有的尺寸单位为mm
⁽²⁾ 减速级数

⁽¹⁾ Dimensions in mm
⁽²⁾ Number of stages

新
NEW

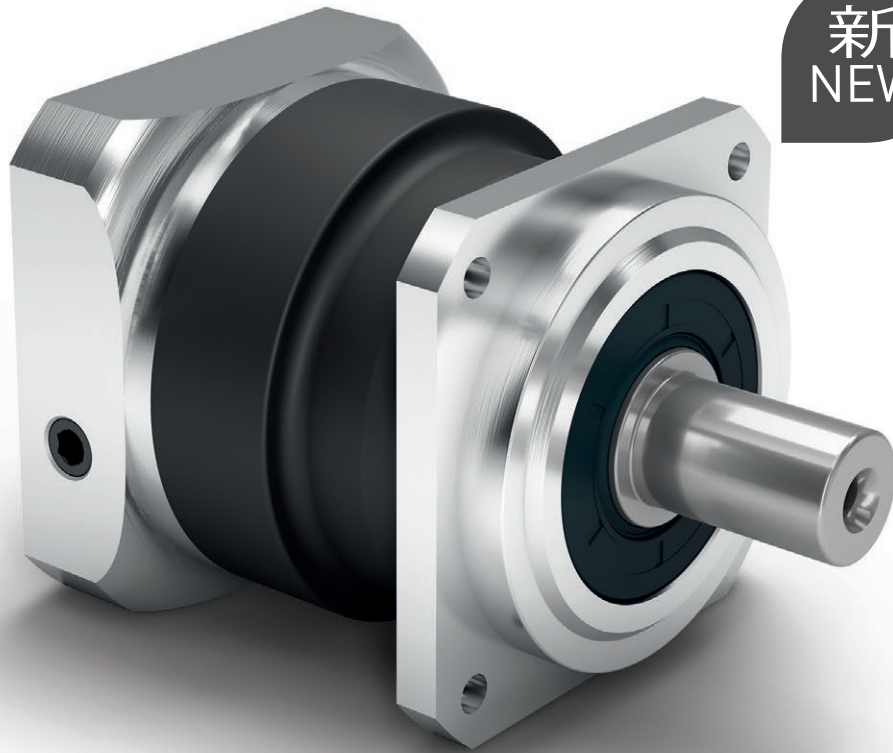

PSBN

高性能精密减速机 配有高精度斜齿 驱动运行时安静无噪音

PSBN 是高精度行星减速机和高效轴承科技的完美结合。专为需要在保证高转速的同时达到最优性能的应用情况而设计。借助高精度的斜齿，其运行十分稳定均匀，且比一般的减速机都要安静。

The high-performance precision planetary gearbox with helical teeth for a particularly quiet drive

Our **PSBN** is the ideal combination of precision planetary gearbox and efficient bearing technology. It has been developed specifically for delivering the maximum performance at high speeds. Its helical teeth provide homogeneous synchronism and quiet running noise.

- ⊕ 回程间隙极小，精度极高 (< 1 弧分)
- ⊕ 可安装在任意位置
- ⊕ 输入法兰可适配特殊的电机
- ⊕ 终生润滑，因此免维护
- ⊕ 旋转方向同向
- ⊕ 输出轴样式多样
- ⊕ 优化转动惯量的锁紧系统

- ⊕ Minimized backlash for maximized precision (< 1 arcmin)
- ⊕ For any mounting position
- ⊕ Individual adaptation of the input flange to the motor
- ⊕ Lifetime lubrication for maintenance-free operation
- ⊕ Equidirectional rotation
- ⊕ Wide range of output shaft designs
- ⊕ Clamping systems with optimized mass moment of inertia

① 斜齿带来质量的提升

这款行星减速机的进步之处在于：**PSBN** 的新型斜齿能够实现最优化的均匀同步运行。振动降至最低，使应用设备上的工件表面和印刷图像的质量得以提高。

② 在高转速的同时实现最优性能

凭借其低摩擦损耗轴承的设计和经过优化的润滑功能，**PSBN** 的运行十分可靠且发热量极低，即使在高要求的生产循环中也是如此。

③ 运行十分安静

我们研发的斜齿能够帮助您节约成本。使用 **PSBN**，便无需在机器上采取各种昂贵的降噪措施。从而提升了整个系统的价值。

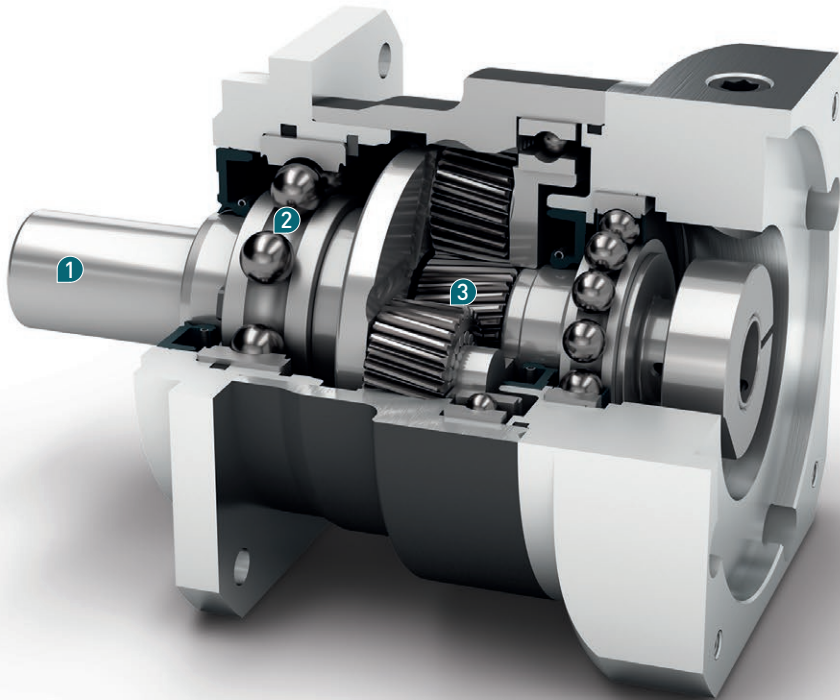

① Helical teeth for enhanced quality

This is progress: The innovative helical teeth of the **PSBN** safeguard the optimal, homogeneous synchronism. Vibrations are minimized for greater workpiece surface and printed quality.

② The highest speed for the best performance

Thanks to its low-friction bearing design and optimized lubrication, the **PSBN** operates with particular reliability and low heat generation – even in complex production cycles.

③ Particularly quiet drive

Our Neugart-developed helical teeth save you money. The **PSBN** does not need expensive sound absorption measures on your machine. The value of the whole system increases as a result.

Code	减速机参数	Gearbox characteristics			PSBN070	PSBN090	PSBN115	z ⁽¹⁾
	使用寿命	Service life	t _L	h	20.000			
	T _{2N} × 0.88 时的使用寿命	Service life at T _{2N} × 0.88			30.000			
	满载时效率 ⁽²⁾	Efficiency at full load ⁽²⁾	η	%	98			
					96			
	最低工作温度	Min. operating temperature	T _{min}	°C	-25			
	最高工作温度	Max. operating temperature	T _{max}		90			
	防护等级	Protection class			IP 65			
S	标准润滑	Standard lubrication			润滑油 / Oil			
F	食品级润滑	Food grade lubrication			润滑油 / Oil			
L	低温润滑 ⁽³⁾	Low temperature lubrication ⁽³⁾			润滑油 / Oil			
	安装位置	Installation position			任意 / Any			
S	标准回程间隙	Standard backlash	j _t	arcmin	< 3			1
					< 5			2
R	降低回程间隙	Reduced backlash			< 2	< 1	< 1	
	抗扭刚度 ⁽²⁾	Torsional stiffness ⁽²⁾	c _g	Nm / arcmin	3,7 - 5,0	7,8 - 10,5	21,5 - 29,0	1
					3,8 - 5,0	7,7 - 10,1	21,0 - 28,0	2
	减速机重量	Gearbox weight	m _G	kg	1,4	2,7	5,6	1
					2,2	3,7	7,1	2
S	标准的箱体表面	Standard surface			箱体: 钢 - 氮碳共渗和后氧化处理 (黑色) Housing: Steel - nitrocarburized and post-oxidized (black)			
	运行噪音 ⁽⁴⁾	Running noise ⁽⁴⁾	Q _g	dB(A)	57	58	63	
	基于减速机输入法兰的最大弯矩 ⁽⁵⁾	Max. bending moment based on the gearbox input flange ⁽⁵⁾	M _b	Nm	18	38	80	1
					18	18	38	2
	电机法兰精度	Motor flange precision			DIN 42955-R			

输出轴载荷	Output shaft loads			PSBN070	PSBN090	PSBN115	z ⁽¹⁾
20,000 h 的径向力 ⁽⁶⁾⁽⁷⁾	Radial force for 20,000 h ⁽⁶⁾⁽⁷⁾	F _{r20.000h}	N	1000	1900	2300	
20,000 h 的轴向力 ⁽⁶⁾⁽⁷⁾	Axial force for 20,000 h ⁽⁶⁾⁽⁷⁾	F _{a20.000h}		1500	3000	4400	
30,000 h 的径向力 ⁽⁶⁾⁽⁷⁾	Radial force for 30,000 h ⁽⁶⁾⁽⁷⁾	F _{r30.000h}		850	1700	2000	
30,000 h 的轴向力 ⁽⁶⁾⁽⁷⁾	Axial force for 30,000 h ⁽⁶⁾⁽⁷⁾	F _{a30.000h}		1300	2500	3700	
静态径向力 ⁽⁷⁾⁽⁸⁾	Static radial force ⁽⁷⁾⁽⁸⁾	F _{rStat}		1600	3100	4500	
静态轴向力 ⁽⁷⁾⁽⁸⁾	Static axial force ⁽⁷⁾⁽⁸⁾	F _{aStat}		1500	2800	4500	
20,000 h 倾斜力矩 ⁽⁶⁾⁽⁸⁾	Tilting moment for 20,000 h ⁽⁶⁾⁽⁸⁾	M _{K20.000h}	Nm	68	154	226	
30,000 h 倾斜力矩 ⁽⁶⁾⁽⁸⁾	Tilting moment for 30,000 h ⁽⁶⁾⁽⁸⁾	M _{K30.000h}		58	138	197	

转动惯量	Moment of inertia			PSBN070	PSBN090	PSBN115	z ⁽¹⁾
转动惯量 ⁽²⁾	Mass moment of inertia ⁽²⁾	J	kgcm ²	0,126 - 0,250	0,324 - 0,760	0,862 - 2,520	1
				0,123 - 0,175	0,124 - 0,200	0,321 - 0,600	2

(1) 减速机级数
 (2) 传动比相关的数值可在 Tec Data Finder 中检索 - www.neugart.com
 (3) T_{min} = -40°C. 理想运行温度最高为 50°C
 (4) 距离减速机 1 m 时; 在输入转速为 n₁=3000 min⁻¹ 且无负荷时测得; i=5
 (5) 最大发动机重量* (单位: kg) = 0.2 × M_b / 发动机长度 (单位: m)
 * 发动机重量对称分布
 * 水平和固定的安装位置
 (6) 数据以 n₂=100 min⁻¹ 的输出轴转速为准。
 (7) 以输出轴中心为准
 (8) 更改 T_{2N}, F_r, F_a 以及周期和轴承使用寿命时, 数值存在偏差 (部分较高)。利用 NCP 针对应用进行专门设计 - www.neugart.com

(1) Number of stages
 (2) The ratio-dependent values can be retrieved in Tec Data Finder - www.neugart.com
 (3) T_{min} = -40°C. Optimal operating temperature max. 50°C
 (4) Sound pressure level from 1 m, measured on input running at n₁=3000 rpm no load; i=5
 (5) Max. motor weight* in kg = 0.2 × M_b / motor length in m
 * with symmetrically distributed motor weight
 * with horizontal and stationary mounting
 (6) These values are based on an output shaft speed of n₂=100 rpm
 (7) Based on center of output shaft
 (8) Other (sometimes higher) values following changes to T_{2N}, F_r, F_a, cycle, and service life of bearing. Application specific configuration with NCP - www.neugart.com

输出扭矩	Output torques			PSBN070	PSBN090	PSBN115	i ⁽¹⁾	z ⁽²⁾
额定输出扭矩 ⁽³⁾⁽⁴⁾	Nominal output torque ⁽³⁾⁽⁴⁾	T _{2N}	Nm	29	54	135	3	1
				39	80	180	4	
				40	80	175	5	
				37	78	175	7	
				39	75	155	8	
				28	59	140	10	
				29	54	135	12	2
				29	54	135	15	
				39	80	180	16	
				39	80	180	20	
				40	80	175	25	
				40	80	175	35	
				39	80	180	40	
				40	80	175	50	
				37	78	175	70	
				28	59	140	100	
最大输出扭矩 ⁽⁴⁾⁽⁵⁾	Max. output torque ⁽⁴⁾⁽⁵⁾	T _{2max}	Nm	46	86	216	3	1
				62	128	288	4	
				64	128	280	5	
				59	125	280	7	
				62	120	248	8	
				45	94	224	10	
				46	86	216	12	2
				46	86	216	15	
				62	128	288	16	
				62	128	288	20	
				64	128	280	25	
				64	128	280	35	
				62	128	288	40	
				64	128	280	50	
				59	125	280	70	
				45	94	224	100	

⁽¹⁾ 传动比 (i=n₁/n₂)

⁽²⁾ 减速机级数

⁽³⁾ 利用 NCP 针对应用进行专门设计 – www.neugart.com

⁽⁴⁾ 平键 (代码 „A”)时的数值: 针对交变载荷

⁽⁵⁾ 允许输出轴转动30,000转; 参见第 128 页

⁽¹⁾ Ratios (i=n₁/n₂)

⁽²⁾ Number of stages

⁽³⁾ Application specific configuration with NCP – www.neugart.com

⁽⁴⁾ Values for feather key (code “A”): for repeated load

⁽⁵⁾ 30,000 rotations of the output shaft permitted; see page 129

输出扭矩	Output torques			PSBN070	PSBN090	PSBN115	i ⁽¹⁾	z ⁽²⁾
急停扭矩 ⁽³⁾	Emergency stop torque ⁽³⁾	T _{2Stop}	Nm	90	210	490	3	1
				120	280	650	4	
				130	280	650	5	
				80	175	340	7	
				90	200	380	8	
				90	200	480	10	
				135	220	500	12	2
				135	220	500	15	
				150	300	650	16	
				150	300	650	20	
				150	300	650	25	
				150	300	650	35	
				150	300	650	40	
				150	300	650	50	
				80	175	340	70	
				80	200	480	100	

输入转速	Input speeds			PSBN070	PSBN090	PSBN115	i ⁽¹⁾	z ⁽²⁾					
T _{2N} 和 S1 时的平均热输入转速 ⁽⁴⁾⁽⁵⁾	Average thermal input speed at T _{2N} and S1 ⁽⁴⁾⁽⁵⁾	n _{1N}	min ⁻¹	3800 ⁽⁶⁾	3400 ⁽⁶⁾	2900 ⁽⁶⁾	3	1					
				4400 ⁽⁶⁾	3700 ⁽⁶⁾	3000 ⁽⁶⁾	4						
				4600 ⁽⁶⁾	3900 ⁽⁶⁾	3500 ⁽⁶⁾	5						
				5000	4500	4000 ⁽⁶⁾	7						
				5000	4500	4000	8						
				5000	4500	4000	10						
				5000	5000	4500	12	2					
				5000	5000	4500	15						
				5000	5000	4500	16						
				5000	5000	4500	20						
				5000	5000	4500	25						
				5000	5000	4500	35						
				5000	5000	4500	40						
				5000	5000	4500	50						
				5000	5000	4500	70						
				5000	5000	4500	100						
				最高机械输入转速 ⁽⁴⁾	Max. mechanical input speed ⁽⁴⁾	n _{1Limit}	min ⁻¹		14000	10000	8500		1
									14000	14000	10000		2

⁽¹⁾ 传动比 (i=n₁/n₂)

⁽²⁾ 减速机级数

⁽³⁾ 允许 1000 次

⁽⁴⁾ 利用 NCP 针对应用设计转速 - www.neugart.com

⁽⁵⁾ 定义请参见第 128 页

⁽⁶⁾ 在 50% T_{2N} 输出和 S1 模式下的平均热传动转速

⁽¹⁾ Ratios (i=n₁/n₂)

⁽²⁾ Number of stages

⁽³⁾ Permitted 1000 times

⁽⁴⁾ Application-specific speed configurations with NCP - www.neugart.com

⁽⁵⁾ See page 129 for the definition

⁽⁶⁾ Average thermal input speed at 50% T_{2N} and S1

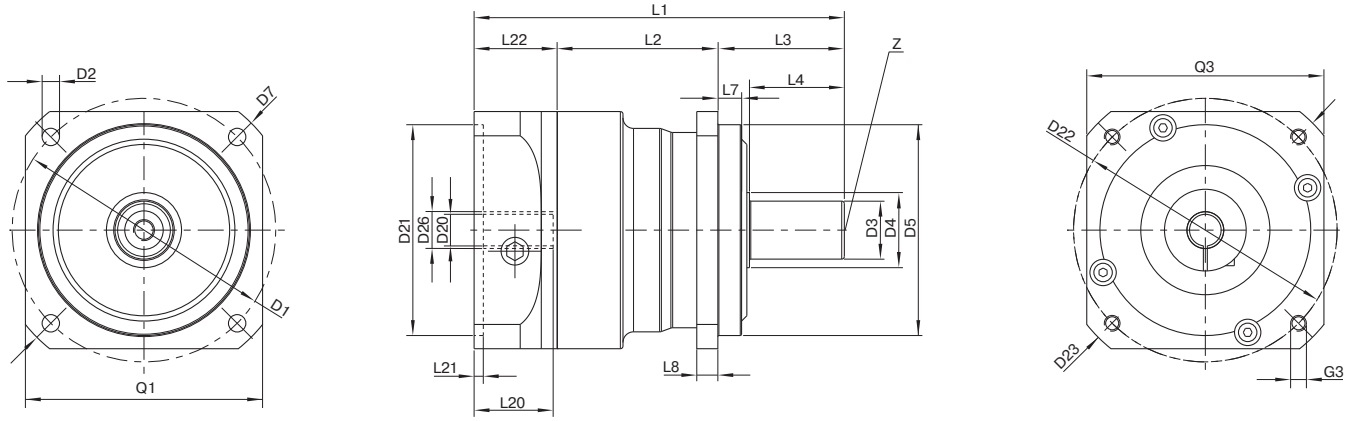

图示为带平键的 PSBN090 / 1 级 / 光滑输出轴 / 14 mm 锁紧系统 / 适配电机法兰 - 2 件式 - 圆形通用法兰 / B5 电机法兰类型
 Drawing corresponds to a PSBN090 / 1-stage / smooth output shaft / 14 mm clamping system / motor adaptation - 2-part - round universal flange / B5 flange type motor
 所有其它变量可在 www.neugart.com 下 Tec Data Finder 中检索 - All other variants can be retrieved in the Tec Data Finder at www.neugart.com

几何尺寸 ⁽¹⁾	Geometry ⁽¹⁾			PSBN070	PSBN090	PSBN115	z ⁽²⁾	Code			
输出端安装孔节圆直径	Pitch circle diameter output	D1		70	100	130					
输出端安装孔直径	Mounting bore output	D2	4x	5,5	6,6	9,0					
输出轴直径	Shaft diameter output	D3	j6	16	22	32					
输出轴轴肩直径	Shaft collar output	D4		23,5	28,5	38,5					
输出端定位凸台直径	Centering diameter output	D5	g6	50	80	110					
输出法兰对角线尺寸	Diagonal dimension output	D7		80	115	148					
输出端法兰外方	Flange cross section output	Q1	■	60	90	115					
最小总长	Min. total length	L1		116,5	140,5	182,5	1				
				145	162,5	204,5	2				
箱体长度	Housing length	L2		54	61	74	1				
				82,5	89	107,5	2				
输出轴轴长	Shaft length output	L3		37	48	65					
输出端定位凸台深度	Centering depth output	L7		6	9	4					
输出端法兰厚度	Flange thickness output	L8		6	8	10					
输入端锁紧系统直径	Clamping system diameter input	D26		更多信息见第 117 页 More information on page 117 具体尺寸视电机/减速机法兰而定。 可以在 www.neugart.com 下 Tec Data Finder. 中针对每个电机适配电机特有的输入法兰几何尺寸 The dimensions vary with the motor/gearbox flange. The input flange geometries can be retrieved for each specific motor in Tec Data Finder at www.neugart.com							
电机轴直径 j6/k6	Motor shaft diameter j6/k6	D20									
最大允许的电机轴长	Max. permis. motor shaft length	L20									
最小允许的电机轴长	Min. permis. motor shaft length										
输入端定位凹槽直径	Centering diameter input	D21									
输入端定位凹槽深度	Centering depth input	L21									
输入端安装孔节圆直径	Pitch circle diameter input	D22									
输入法兰长度	Motor flange length	L22									
输入法兰对角线尺寸	Diagonal dimension input	D23									
安装螺纹 x 深度	Mounting thread x depth	G3	4x								
输入端法兰外方	Flange cross section input	Q3	■								
附带平键的输出轴 (DIN 6885-1)	Output shaft with feather key (DIN 6885-1)						A 5x5x25	A 6x6x28	A 10x8x50		
平键宽度 (DIN 6885-1)	Feather key width (DIN 6885-1)	B1					5	6	10		
含平键在内的轴高 (DIN 6885-1)	Shaft height including feather key (DIN 6885-1)	H1					18	24,5	35		A
到轴肩的距离	Shaft length from shoulder	L4					28	36	58		
平键长度	Feather key length	L5		25	28	50					
到轴端的距离	Distance from shaft end	L6		2	4	4					
中心孔 (DIN 332, DR 形)	Center hole (DIN 332, type DR)	Z		M5x12,5	M8x19	M12x28					
光滑输出轴	Smooth output shaft										
到轴肩的距离	Shaft length from shoulder	L4		28	36	58		B			
中心孔 (DIN 332, DR 形)	Center hole (DIN 332, type DR)	Z		M5x12,5	M8x19	M12x28					

⁽¹⁾ 所有的尺寸单位为mm
⁽²⁾ 减速机级数

⁽¹⁾ Dimensions in mm
⁽²⁾ Number of stages

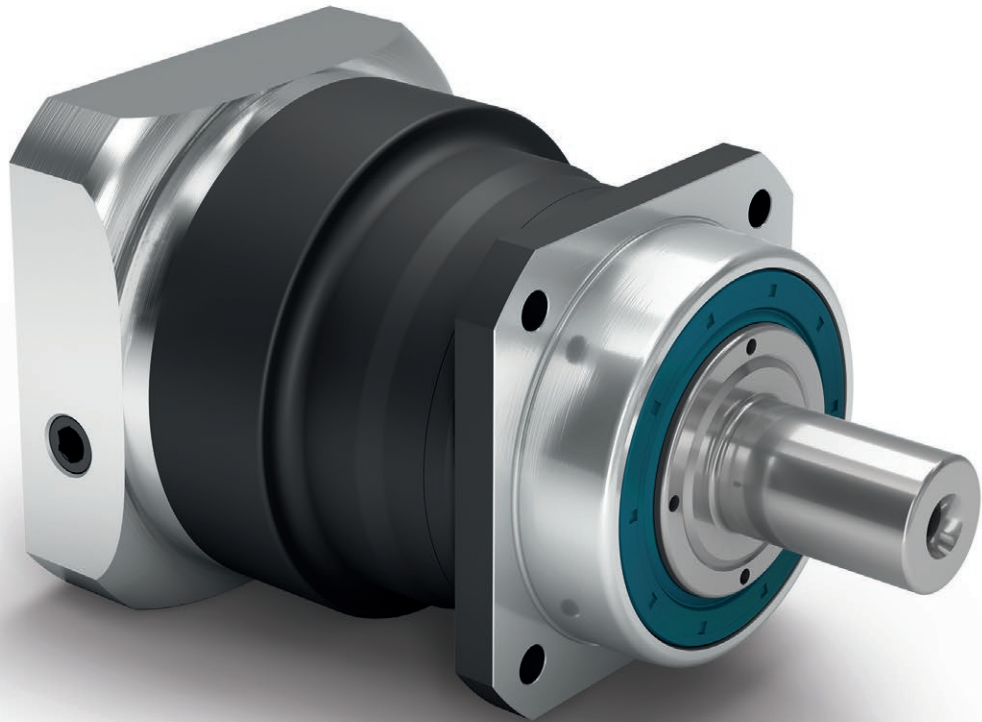

PSN

斜齿高精度减速机能够实现噪音极低的同步运行，轴承负载能力强

PSN 的进步之处在于：其新型斜齿齿轮能够实现噪音极低的同步运行。使用这款高精度行星减速机时，振动将降至最低——可以在轴承负载极高时提高工件表面的质量。

The helical-toothed precision planetary gearbox for low-noise operation and high bearing loads

Our PSN embodies pure progress: Its innovative helical teeth safeguard low-noise operations. This precision planetary gearbox minimizes vibrations, and therefore increases the quality of your workpiece surfaces even under the highest bearing loads.

- ⊕ 回程间隙极小，精度极高 (< 1 弧分)
- ⊕ 可安装在任意位置
- ⊕ 输入法兰可适配特殊的电机
- ⊕ 终生润滑，因此免维护
- ⊕ 旋转方向同向
- ⊕ 输出轴样式多样
- ⊕ 优化转动惯量的锁紧系统

- ⊕ Minimized backlash for maximized precision (< 1 arcmin)
- ⊕ For any mounting position
- ⊕ Individual adaptation of the input flange to the motor
- ⊕ Lifetime lubrication for maintenance-free operation
- ⊕ Equidirectional rotation
- ⊕ Wide range of output shaft designs
- ⊕ Clamping systems with optimized mass moment of inertia

1 斜齿可提高质量

这款行星减速机的进步之处在于：**PSN** 的新型斜齿轮能够实现最优化的均匀同步运行。振动降至最低，使应用设备上的工件表面和印刷图像的质量得以提高。

2 最高负载时仍能保持绝佳刚性

PSN 配有预紧的圆锥滚子轴承适用于极端条件下。即使运行方向频繁切换，此款减速机也绝不会丧失必要的刚性，因此也适用于负载极高的情况。

3 运行十分安静

下列优势提升了整个系统的价值：使用斜齿轮式 **PSN** 时，机器无需采取其他降噪措施。

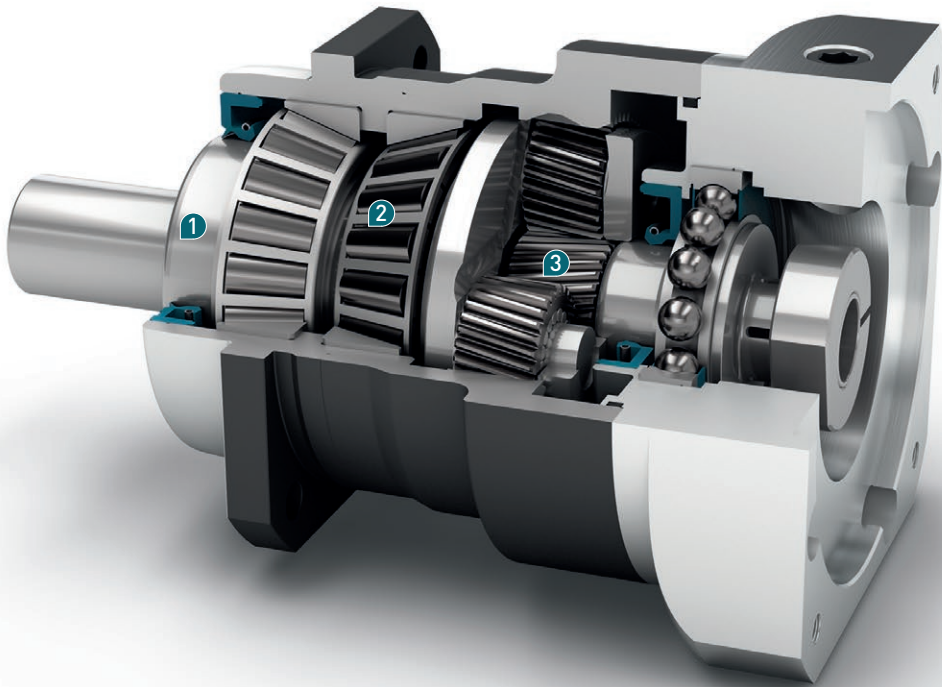

1 Helical teeth for better quality

This is progress: The innovative helical teeth of the **PSN** safeguard the optimal, homogeneous synchronism. Vibrations are minimized for greater workpiece surface and printed quality.

2 Perfect stiffness even under the highest loads

The prestressed tapered roller bearings in the **PSN** can withstand extremely high loads. Even under changing equidirectional rotations, this gearbox never loses the required stiffness. It is therefore the ideal solution for the highest loads.

3 Particularly quiet drive

The value of your system increases as a result. Thanks to the helical teeth in the **PSN**, your machine does not need any additional sound absorbent measures.

Code	减速机参数	Gearbox characteristics			PSN070	PSN090	PSN115	PSN142	PSN190	z ⁽¹⁾	
	使用寿命	Service life	t _L	h	20.000						
	T _{2N} × 0.88 时的使用寿命	Service life at T _{2N} × 0.88			30.000						
	满载时效率 ⁽²⁾	Efficiency at full load ⁽²⁾	η	%	98					1	
	最低工作温度	Min. operating temperature	T _{min}	°C	-25						
	最高工作温度	Max. operating temperature	T _{max}		90						
	防护等级	Protection class	IP 65								
S	标准润滑	Standard lubrication	润滑油 / Oil								
F	食品级润滑	Food grade lubrication	润滑油 / Oil								
L	低温润滑 ⁽³⁾	Low temperature lubrication ⁽³⁾	润滑油 / Oil								
	安装位置	Installation position	任意 / Any								
S	标准回程间隙	Standard backlash	j _t	arcmin	< 3					1	
R	降低回程间隙	Reduced backlash			< 5					2	
	抗扭刚度 ⁽²⁾	Torsional stiffness ⁽²⁾	c _g	Nm / arcmin	3,5 - 5,0	7,3 - 10,5	20,0 - 29,0	35,0 - 51,0	122,0 - 175,0	1	
	减速机重量	Gearbox weight			m _G	kg	3,6 - 5,0	7,2 - 10,1	19,5 - 28,0	34,0 - 49,0	120,0 - 168,0
					1,9	3,3	6,9	15,7	36	1	
					2,7	4,3	8,4	17	39,7	2	
S	标准的箱体表面	Standard surface	箱体: 钢 - 氮碳共渗和后氧化处理 (黑色) Housing: Steel - nitrocarburized and post-oxidized (black)								
	运行噪音 ⁽⁴⁾	Running noise ⁽⁴⁾	Q _g	dB(A)	57	58	63	66	68		
	基于减速机输入法兰的最大弯矩 ⁽⁵⁾	Max. bending moment based on the gearbox input flange ⁽⁵⁾	M _b	Nm	18	38	80	180	300	1	
	电机法兰精度	Motor flange precision			DIN 42955-R					180	2

输出轴载荷	Output shaft loads			PSN070	PSN090	PSN115	PSN142	PSN190	z ⁽¹⁾
20,000 h 的径向力 ⁽⁶⁾⁽⁷⁾	Radial force for 20,000 h ⁽⁶⁾⁽⁷⁾	F _{r20.000h}	N	3200	5500	6000	13000	20000	
20,000 h 的轴向力 ⁽⁶⁾⁽⁷⁾	Axial force for 20,000 h ⁽⁶⁾⁽⁷⁾	F _{a20.000h}		4400	6400	8000	15000	19000	
30,000 h 的径向力 ⁽⁶⁾⁽⁷⁾	Radial force for 30,000 h ⁽⁶⁾⁽⁷⁾	F _{r30.000h}		3200	4800	5400	11500	17500	
30,000 h 的轴向力 ⁽⁶⁾⁽⁷⁾	Axial force for 30,000 h ⁽⁶⁾⁽⁷⁾	F _{a30.000h}		3900	5700	7000	13500	18500	
静态径向力 ⁽⁷⁾⁽⁸⁾	Static radial force ⁽⁷⁾⁽⁸⁾	F _{r Stat}		3200	5500	6000	13000	20000	
静态轴向力 ⁽⁷⁾⁽⁸⁾	Static axial force ⁽⁷⁾⁽⁸⁾	F _{a Stat}		4400	6400	8000	15000	19000	
20,000 h 倾斜力矩 ⁽⁶⁾⁽⁸⁾	Tilting moment for 20,000 h ⁽⁶⁾⁽⁸⁾	M _{K20.000h}	Nm	203	419	562	1566	2887	
30,000 h 倾斜力矩 ⁽⁶⁾⁽⁸⁾	Tilting moment for 30,000 h ⁽⁶⁾⁽⁸⁾	M _{K30.000h}		203	366	506	1385	2526	

转动惯量	Moment of inertia			PSN070	PSN090	PSN115	PSN142	PSN190	z ⁽¹⁾
转动惯量 ⁽²⁾	Mass moment of inertia ⁽²⁾	J	kgcm ²	0,128	0,330	0,857	6,475	21,695	1
				-	-	-	-	-	
				0,272	0,811	2,484	13,112	53,182	2
				0,123	0,124	0,321	0,840	6,360	
				0,177	0,227	0,600	1,962	10,654	

(1) 减速机级数
 (2) 传动比相关的数值可在 Tec Data Finder 中检索 - www.neugart.com
 (3) T_{min} = -40°C. 理想运行温度最高为 50°C
 (4) 距离减速机 1 m 时; 在输入转速为 n₁=3000 min⁻¹ 且无负荷时测得; i=5
 (5) 最大发动机重量* (单位: kg) = 0.2 × M_b / 发动机长度 (单位: m)
 * 发动机重量对称分布
 * 水平和固定的安装位置
 (6) 数据以 n₂=100 min⁻¹ 的输出轴转速为准。
 (7) 以输出轴中心为准
 (8) 更改 T_{2N}, F_r, F_a 以及周期和轴承使用寿命时, 数值存在偏差 (部分较高)。利用 NCP 针对应用进行专门设计 - www.neugart.com

(1) Number of stages
 (2) The ratio-dependent values can be retrieved in Tec Data Finder - www.neugart.com
 (3) T_{min} = -40°C. Optimal operating temperature max. 50°C
 (4) Sound pressure level from 1 m, measured on input running at n₁=3000 rpm no load; i=5
 (5) Max. motor weight* in kg = 0.2 × M_b / motor length in m
 * with symmetrically distributed motor weight
 * with horizontal and stationary mounting
 (6) These values are based on an output shaft speed of n₂=100 rpm
 (7) Based on center of output shaft
 (8) Other (sometimes higher) values following changes to T_{2N}, F_r, F_a, cycle, and service life of bearing. Application specific configuration with NCP - www.neugart.com

输出扭矩	Output torques			PSN070	PSN090	PSN115	PSN142	PSN190	i ⁽¹⁾	z ⁽²⁾
额定输出扭矩 ⁽³⁾⁽⁴⁾	Nominal output torque ⁽³⁾⁽⁴⁾	T _{2N}	Nm	29	54	135	380	845	3	1
				39	80	180	470	950	4	
				40	80	175	405	950	5	
				37	78	175	355	900	7	
				28	59	140	305	750	10	2
				29	54	135	380	845	12	
				29	54	135	380	845	15	
				39	80	180	450	950	16	
				39	80	180	450	950	20	
				40	80	175	405	950	25	
				40	80	175	405	950	35	
				39	80	180	470	950	40	
				40	80	175	405	950	50	
				37	78	175	355	900	70	
28	59	140	305	750	100					
最大输出扭矩 ⁽⁴⁾⁽⁵⁾	Max. output torque ⁽⁴⁾⁽⁵⁾	T _{2max}	Nm	46	86	216	608	1352	3	1
				62	128	288	752	1520	4	
				64	128	280	648	1520	5	
				59	125	280	568	1440	7	
				45	94	224	488	1200	10	2
				46	86	216	608	1352	12	
				46	86	216	608	1352	15	
				62	128	288	720	1520	16	
				62	128	288	720	1520	20	
				64	128	280	648	1520	25	
				64	128	280	648	1520	35	
				62	128	288	752	1520	40	
				64	128	280	648	1520	50	
				59	125	280	568	1440	70	
45	94	224	488	1200	100					

⁽¹⁾ 传动比 (i=n₁/n₂)

⁽²⁾ 减速机级数

⁽³⁾ 利用 NCP 针对应用进行专门设计 – www.neugart.com

⁽⁴⁾ 平键 (代码 „A”)时的数值: 针对交变载荷

⁽⁵⁾ 允许输出轴转动30,000转; 参见第 128 页

⁽¹⁾ Ratios (i=n₁/n₂)

⁽²⁾ Number of stages

⁽³⁾ Application specific configuration with NCP – www.neugart.com

⁽⁴⁾ Values for feather key (code "A"): for repeated load

⁽⁵⁾ 30,000 rotations of the output shaft permitted; see page 129

输出扭矩	Output torques			PSN070	PSN090	PSN115	PSN142	PSN190	i ⁽¹⁾	z ⁽²⁾
急停扭矩 ⁽³⁾	Emergency stop torque ⁽³⁾	T _{2Stop}	Nm	90	210	490	1250	2400	3	1
				120	280	650	1650	3200	4	
				130	280	650	1650	3200	5	
				80	175	340	1300	3200	7	
				90	200	480	600	1700	10	
				135	220	500	1250	2400	12	2
				135	220	500	1250	2400	15	
				150	300	650	1650	3200	16	
				150	300	650	1650	3200	20	
				150	300	650	1650	3200	25	
				150	300	650	1650	3200	35	
				150	300	650	1650	3200	40	
				150	300	650	1650	3200	50	
				80	175	340	1300	3200	70	
				80	200	480	600	1700	100	

输入转速	Input speeds			PSN070	PSN090	PSN115	PSN142	PSN190	i ⁽¹⁾	z ⁽²⁾
T _{2N} 和 S1 时的平均热输入转速 ⁽⁴⁾⁽⁵⁾	Average thermal input speed at T _{2N} and S1 ⁽⁴⁾⁽⁵⁾	n _{1N}	min ⁻¹	3000 ⁽⁶⁾	2700 ⁽⁶⁾	2000 ⁽⁶⁾	1000 ⁽⁶⁾	750 ⁽⁶⁾	3	1
				3700 ⁽⁶⁾	3050 ⁽⁶⁾	2250 ⁽⁶⁾	1250 ⁽⁶⁾	900 ⁽⁶⁾	4	
				4400 ⁽⁶⁾	3700 ⁽⁶⁾	2750 ⁽⁶⁾	1550 ⁽⁶⁾	1100 ⁽⁶⁾	5	
				4500	4000	3500 ⁽⁶⁾	2000 ⁽⁶⁾	1450 ⁽⁶⁾	7	
				4500	4000	3500	2500 ⁽⁶⁾	1900 ⁽⁶⁾	10	
				4500	4500	4000 ⁽⁶⁾	2400 ⁽⁶⁾	1550 ⁽⁶⁾	12	2
				4500	4500	4000	3000 ⁽⁶⁾	1900 ⁽⁶⁾	15	
				4500	4500	4000 ⁽⁶⁾	2600 ⁽⁶⁾	1650 ⁽⁶⁾	16	
				4500	4500	4000	3250 ⁽⁶⁾	2050 ⁽⁶⁾	20	
				4500	4500	4000	3500 ⁽⁶⁾	2200 ⁽⁶⁾	25	
				4500	4500	4000	3500	2800 ⁽⁶⁾	35	
				4500	4500	4000	3500	3000 ⁽⁶⁾	40	
				4500	4500	4000	3500	3000	50	
				4500	4500	4000	3500	3000	70	
				4500	4500	4000	3500	3000	100	
				最高机械输入转速 ⁽⁴⁾	Max. mechanical input speed ⁽⁴⁾	n _{1Limit}	min ⁻¹	14000	10000	
14000	14000	10000	8500					6500		2

⁽¹⁾ 传动比 (i=n₁/n₂)

⁽²⁾ 减速机级数

⁽³⁾ 允许 1000 次

⁽⁴⁾ 利用 NCP 针对应用设计转速- www.neugart.com

⁽⁵⁾ 定义请参见第 128 页

⁽⁶⁾ 在 50% T_{2N} 输出和 S1 模式下的平均热传动转速

⁽¹⁾ Ratios (i=n₁/n₂)

⁽²⁾ Number of stages

⁽³⁾ Permitted 1000 times

⁽⁴⁾ Application-specific speed configurations with NCP – www.neugart.com

⁽⁵⁾ See page 129 for the definition

⁽⁶⁾ Average thermal input speed at 50% T_{2N} and S1

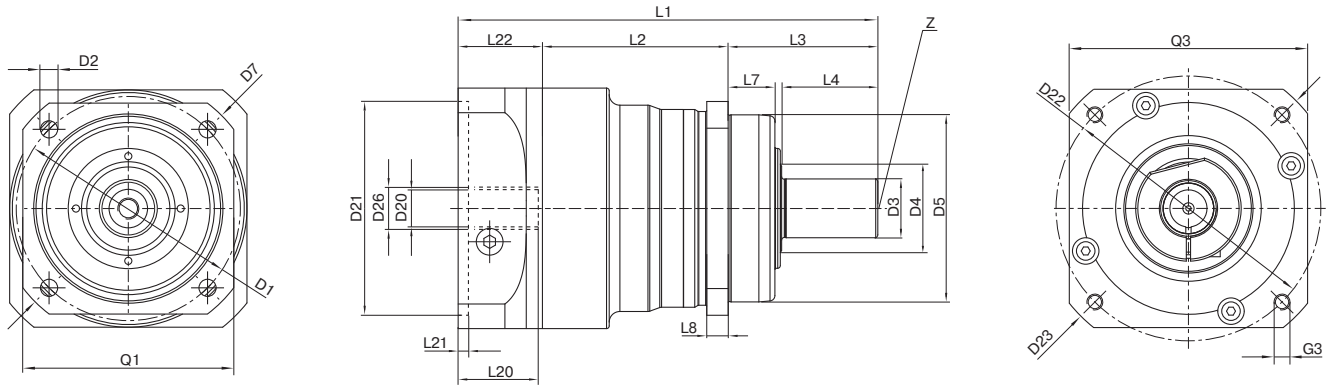

图示为带平键的 PSN090 / 1 级 / 光滑输出轴 / 14 mm 锁紧系统 / 适配电机法兰 - 2 件式 - 圆形通用法兰 / B5 电机法兰类型
 Drawing corresponds to a PSN090 / 1-stage / smooth output shaft / 14 mm clamping system / motor adaptation - 2-part - round universal flange / B5 flange type motor
 所有其它变量可在 www.neugart.com 下 Tec Data Finder 中检索 - All other variants can be retrieved in the Tec Data Finder at www.neugart.com

几何尺寸 ⁽¹⁾	Geometry ⁽¹⁾			PSN070	PSN090	PSN115	PSN142	PSN190	z ⁽²⁾	Code
输出端安装孔节圆直径	Pitch circle diameter output	D1		68 - 75	85	120	165	215		
输出端安装孔直径	Mounting bore output	D2	4x	5,5	6,5	9,0	11,0	13,5		
输出轴直径	Shaft diameter output	D3	k6	16	22	32	40	55		
输出轴轴肩直径	Shaft collar output	D4		21,5	31,5	41,5	57,5	76,5		
输出端定位凸台直径	Centering diameter output	D5	g7	60	70	90	130	160		
输出法兰对角线尺寸	Diagonal dimension output	D7		92	100	140	185	240		
输出端法兰外方	Flange cross section output	Q1	■	70	80	110	142	190		
最小总长	Min. total length	L1		134	157	202,5	261,5	310,5	1	
				162,5	179	224,5	292,5	355,5	2	
箱体长度	Housing length	L2		60,5	69,5	71	101	130,5	1	
				89	97,5	105	138,5	193,5	2	
输出端定位凸台深度	Centering depth output	L7		19	17,5	28	28	28		
输出端法兰厚度	Flange thickness output	L8		7	8	10	12	15		
中心孔 (DIN 332, DR 形)	Center hole (DIN 332, type DR)	Z		M5x12,5	M8x19	M12x28	M16x36	M20x42		
输入端锁紧系统直径	Clamping system diameter input	D26		更多信息见第 117 页 More information on page 117						
电机轴直径 j6/k6	Motor shaft diameter j6/k6	D20		具体尺寸视电机/减速机法兰而定。 可以在 www.neugart.com 下 Tec Data Finder. 中针对每个电机适配电机特有的输入法兰几何尺寸 The dimensions vary with the motor/gearbox flange. The input flange geometries can be retrieved for each specific motor in Tec Data Finder at www.neugart.com						
最大允许的电机轴长	Max. permis. motor shaft length									
最小允许的电机轴长	Min. permis. motor shaft length	L20								
输入端定位凹槽直径	Centering diameter input	D21								
输入端定位凹槽深度	Centering depth input	L21								
输入端安装孔节圆直径	Pitch circle diameter input	D22								
输入法兰长度	Motor flange length	L22								
输入法兰对角线尺寸	Diagonal dimension input	D23								
安装螺纹 x 深度	Mounting thread x depth	G3	4x							
输入端法兰外方	Flange cross section input	Q3	■							
附带平键的输出轴 (DIN 6885-1)	Output shaft with feather key (DIN 6885-1)			A 5x5x25	A 6x6x28	A 10x8x50	A 12x8x65	A 16x10x70		
平键宽度 (DIN 6885-1)	Feather key width (DIN 6885-1)	B1		5	6	10	12	16		
含平键在内的轴高 (DIN 6885-1)	Shaft height including feather key (DIN 6885-1)	H1		18	24,5	35	43	59		A
输出轴轴长	Shaft length output	L3		48	56	88	110	112		
到轴肩的距离	Shaft length from shoulder	L4		28	36	58	80	82		
平键长度	Feather key length	L5		25	28	50	65	70		
到轴端的距离	Distance from shaft end	L6		2	4	4	8	6		
光滑输出轴	Smooth output shaft									
输出轴轴长	Shaft length output	L3		48	56	88	110	112		B
到轴肩的距离	Shaft length from shoulder	L4		28	36	58	80	82		
花键输出轴 (DIN 5480)	Toothed output shaft (DIN 5480)			W16x0,8 x18x6m	W22x1,25 x16x6m	W32x1,25x 24x6m	W40x2,0x 18x6m	W55x2,0x 26x6m		
花键或键槽的长度	Width of gearing	L _v		15	15	15	20	22		C
输出轴轴长	Shaft length output	L3		46	46	56	70	72		
到轴肩的距离	Shaft length from shoulder	L4		26	26	26	40	41,5		

⁽¹⁾ 所有的尺寸单位为mm
⁽²⁾ 减速机级数

⁽¹⁾ Dimensions in mm
⁽²⁾ Number of stages

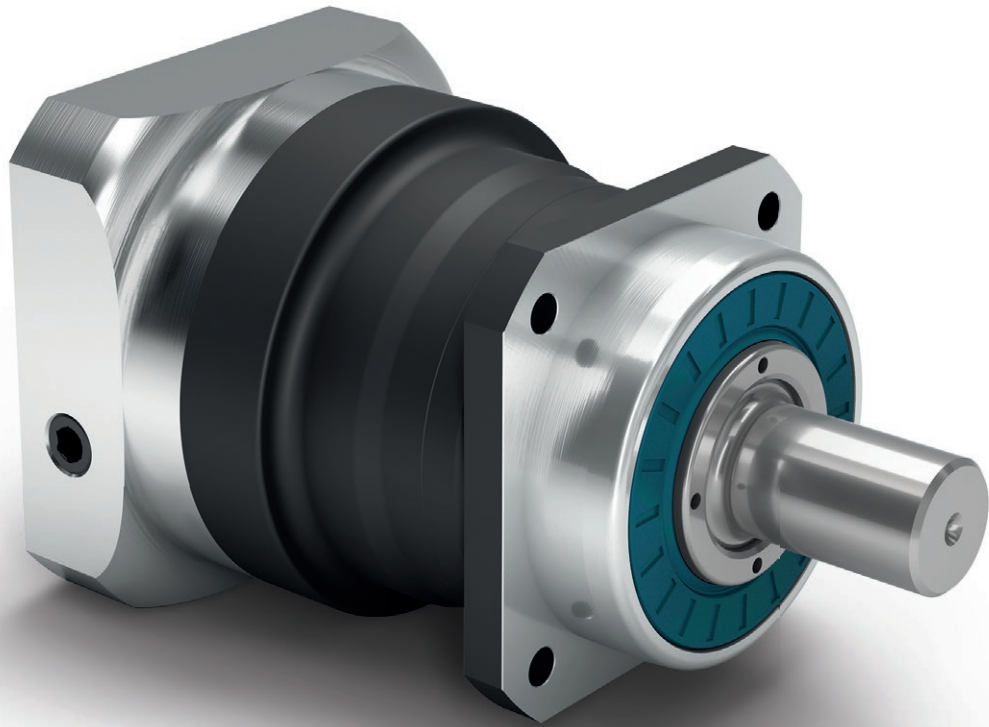

PLN

这款完全密封的直齿行星减速机能够提供极高的效能，且不会损失必要的刚性

这款直齿高精度行星减速机适用于需实现最高效能和扭矩的应用情况。**PLN** 配有预紧的圆锥滚子轴承和我们自主研发的密封件保证了在有灰尘和喷溅水的环境下机器仍能提供最佳性能。

- + 回程间隙极小，精度极高 (< 1 弧分)
- + 可安装在任意位置
- + 输入法兰可适配特殊的电机
- + 终生润滑，因此免维护
- + 旋转方向同向
- + 输出轴样式多样
- + 优化转动惯量的锁紧系统

The perfectly sealed straight-toothed planetary gearbox delivers the maximum performance without ever losing the required stiffness

Our straight-toothed precision planetary gearbox has been designed for the highest performance and torque. The prestressed tapered roller bearings in the **PLN** and the seal we have developed safeguard the optimal performance even against dust and water jets.

- + Minimized backlash for maximized precision (< 1 arcmin)
- + For any mounting position
- + Individual adaptation of the input flange to the motor
- + Lifetime lubrication for maintenance-free operation
- + Equidirectional rotation
- + Wide range of output shaft designs
- + Clamping systems with optimized mass moment of inertia

1 完全密封

灰尘或喷溅水完全不会影响到此款减速机。由于其配有径向轴密封件，**PLN** 在极为严苛的环境条件下也能发挥出最佳水平。其防护等级为 IP65，借助智能型结构设计，**PLN** 能够得到绝佳保护。

2 最高负载时仍能保持绝佳刚性

凭借其预紧的圆锥滚子轴承，**PLN** 能够始终保持绝佳的刚性，这是一种值得您永久信任的解决方案。

3 直齿可实现极高的扭矩

PLN 配有直齿轮，适用于高性能应用。由于其智能化设计，该款产品的功率密度比传统行星减速机更高。

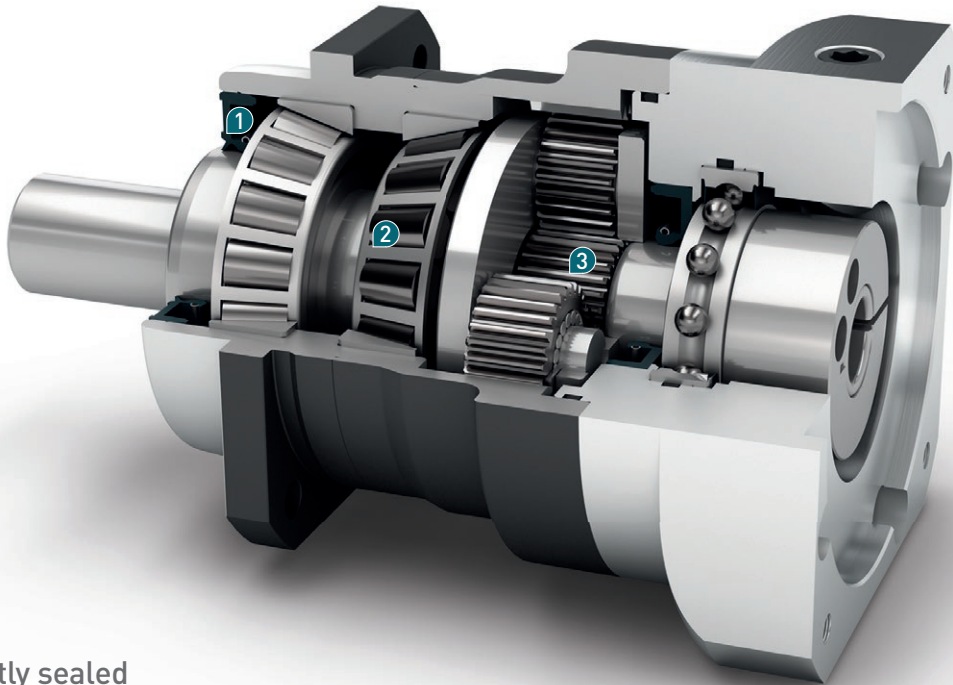

1 Perfectly sealed

This gearbox resists dust and water jets. Thanks to its radial shaft seal, the **PLN** is also ideal in the most grueling conditions. Perfect IP 65 protection class, by means of its smart design.

2 Perfect stiffness even under the highest loads

Thanks to its prestressed tapered roller bearings, the **PLN** always maintains the optimal stiffness and is therefore a solution that never lets you down.

3 Straight teeth for the highest torques

Due to its straight teeth, the **PLN** is ideal for the highest performance. Its intelligent design delivers greater power than conventional planetary gearboxes.

Code	减速机参数	Gearbox characteristics			PLN070	PLN090	PLN115	PLN142	PLN190	z ⁽¹⁾	
	使用寿命	Service life	t _L	h	20.000						
	T _{2N} × 0.88 时的使用寿命	Service life at T _{2N} × 0.88			30.000						
	满载时效率 ⁽²⁾	Efficiency at full load ⁽²⁾	η	%	98					1	
	最低工作温度	Min. operating temperature	T _{min}	°C	-25						
	最高工作温度	Max. operating temperature	T _{max}		90						
	防护等级	Protection class	IP 65								
S	标准润滑	Standard lubrication	润滑油 / Oil								
F	食品级润滑	Food grade lubrication	润滑油 / Oil								
L	低温润滑 ⁽³⁾	Low temperature lubrication ⁽³⁾	润滑油 / Oil								
	安装位置	Installation position	任意 / Any								
S	标准回程间隙	Standard backlash	j _t	arcmin	< 3					1	
R	降低回程间隙	Reduced backlash			< 5					2	
	抗扭刚度 ⁽²⁾	Torsional stiffness ⁽²⁾	c _g	Nm / arcmin	4,2 - 6,0	8,0 - 11,5	18,0 - 26,5	42,0 - 61,0	115,0 - 165,0	1	
					4,3 - 6,0	8,1 - 11,5	18,5 - 26,5	43,0 - 61,0	117,0 - 165,0	2	
	减速机重量	Gearbox weight	m _G	kg	1,9	3,3	6,9	16	30,5	1	
					2,4	4,2	9,5	20,5	45	2	
S	标准的箱体表面	Standard surface	箱体: 钢 - 氮碳共渗和后氧化处理 (黑色) Housing: Steel - nitrocarburized and post-oxidized (black)								
	运行噪音 ⁽⁴⁾	Running noise ⁽⁴⁾	Q _g	dB(A)	60	62	65	70	74		
	基于减速机输入法兰的最大弯矩 ⁽⁵⁾	Max. bending moment based on the gearbox input flange ⁽⁵⁾	M _b	Nm	18	38	80	180	300		
	电机法兰精度	Motor flange precision	DIN 42955-R								

输出轴载荷	Output shaft loads			PLN070	PLN090	PLN115	PLN142	PLN190	z ⁽¹⁾
20,000 h 的径向力 ⁽⁶⁾⁽⁷⁾	Radial force for 20,000 h ⁽⁶⁾⁽⁷⁾	F _{r20.000h}	N	3200	5500	6000	12500	21000	
20,000 h 的轴向力 ⁽⁶⁾⁽⁷⁾	Axial force for 20,000 h ⁽⁶⁾⁽⁷⁾	F _{a20.000h}		4400	6400	8000	15000	21000	
30,000 h 的径向力 ⁽⁶⁾⁽⁷⁾	Radial force for 30,000 h ⁽⁶⁾⁽⁷⁾	F _{r30.000h}		3200	4800	5400	11400	18000	
30,000 h 的轴向力 ⁽⁶⁾⁽⁷⁾	Axial force for 30,000 h ⁽⁶⁾⁽⁷⁾	F _{a30.000h}		3900	5700	7000	13200	18500	
静态径向力 ⁽⁷⁾⁽⁸⁾	Static radial force ⁽⁷⁾⁽⁸⁾	F _{r Stat}		3200	5500	6000	12500	21000	
静态轴向力 ⁽⁷⁾⁽⁸⁾	Static axial force ⁽⁷⁾⁽⁸⁾	F _{a Stat}		4400	6400	8000	15000	21000	
20,000 h 倾斜力矩 ⁽⁶⁾⁽⁸⁾	Tilting moment for 20,000 h ⁽⁶⁾⁽⁸⁾	M _{K20.000h}	Nm	191	383	488	1420	2535	
30,000 h 倾斜力矩 ⁽⁶⁾⁽⁸⁾	Tilting moment for 30,000 h ⁽⁶⁾⁽⁸⁾	M _{K30.000h}		191	335	439	1295	2173	

转动惯量	Moment of inertia			PLN070	PLN090	PLN115	PLN142	PLN190	z ⁽¹⁾
转动惯量 ⁽²⁾	Mass moment of inertia ⁽²⁾	J	kgcm ²	0,216	0,560	1,942	7,008	22,882	1
				-	-	-	-	-	
				0,365	1,028	3,256	15,270	63,821	2
				0,209	0,544	1,933	6,811	22,430	
				0,249	0,699	2,373	9,813	36,003	

(1) 减速机级数
 (2) 传动比相关的数值可在 Tec Data Finder 中检索 - www.neugart.com
 (3) T_{min} = -40°C. 理想运行温度最高为 50°C
 (4) 距离减速机 1 m 时; 在输入转速为 n₁=3000 min⁻¹ 且无负荷时测得; i=5
 (5) 最大发动机重量* (单位: kg) = 0.2 × M_b / 发动机长度 (单位: m)
 * 发动机重量对称分布
 * 水平和固定的安装位置
 (6) 数据以 n₂=100 min⁻¹ 的输出轴转速为准。
 (7) 以输出轴中心为准
 (8) 更改 T_{2N}, F_r, F_a 以及周期和轴承使用寿命时, 数值存在偏差 (部分较高)。利用 NCP 针对应用进行专门设计 - www.neugart.com

(1) Number of stages
 (2) The ratio-dependent values can be retrieved in Tec Data Finder - www.neugart.com
 (3) T_{min} = -40°C. Optimal operating temperature max. 50°C
 (4) Sound pressure level from 1 m, measured on input running at n₁=3000 rpm no load; i=5
 (5) Max. motor weight* in kg = 0.2 × M_b / motor length in m
 * with symmetrically distributed motor weight
 * with horizontal and stationary mounting
 (6) These values are based on an output shaft speed of n₂=100 rpm
 (7) Based on center of output shaft
 (8) Other (sometimes higher) values following changes to T_{2N}, F_r, F_a, cycle, and service life of bearing. Application specific configuration with NCP - www.neugart.com

输出扭矩	Output torques			PLN070	PLN090	PLN115	PLN142	PLN190	i ⁽¹⁾	z ⁽²⁾
额定输出扭矩 ⁽³⁾⁽⁴⁾	Nominal output torque ⁽³⁾⁽⁴⁾	T _{2N}	Nm	45	100	230	450	1000	3	1
				60	140	300	600	1300	4	
				65	140	260	750	1600	5	
				45	90	180	530	1300	7	
				40	80	150	450	1000	8	
				27	60	125	305	630	10	
				68	110	250	780	1500	12	
				68	110	250	780	1500	15	
				77	150	300	1000	1800	16	
				77	150	300	1000	1800	20	
				65	140	260	900	1800	25	
				77	150	300	1000	1800	32	
				65	140	260	900	1800	40	
				40	80	150	450	1000	64	
				27	60	125	305	630	100	
				最大输出扭矩 ⁽⁴⁾⁽⁵⁾	Max. output torque ⁽⁴⁾⁽⁵⁾	T _{2max}	Nm	72	160	368
96	224	480	960					2080	4	
104	224	416	1200					2560	5	
72	144	288	848					2080	7	
64	128	240	720					1600	8	
43	96	200	488					1008	10	
109	176	400	1248					2400	12	
109	176	400	1248					2400	15	
123	240	480	1600					2880	16	
123	240	480	1600					2880	20	
104	224	416	1440					2880	25	
123	240	480	1600					2880	32	
104	224	416	1440					2880	40	
64	128	240	720					1600	64	
43	96	200	488					1008	100	

⁽¹⁾ 传动比 (i=n₁/n₂)

⁽²⁾ 减速机级数

⁽³⁾ 利用 NCP 针对应用进行专门设计 – www.neugart.com

⁽⁴⁾ 平键 (代码 „A”)时的数值: 针对交变载荷

⁽⁵⁾ 允许输出轴转动30,000转; 参见第 128 页

⁽¹⁾ Ratios (i=n₁/n₂)

⁽²⁾ Number of stages

⁽³⁾ Application specific configuration with NCP – www.neugart.com

⁽⁴⁾ Values for feather key (code "A"): for repeated load

⁽⁵⁾ 30,000 rotations of the output shaft permitted; see page 129

输出扭矩	Output torques			PLN070	PLN090	PLN115	PLN142	PLN190	i ⁽¹⁾	z ⁽²⁾
急停扭矩 ⁽³⁾	Emergency stop torque ⁽³⁾	T _{2Stop}	Nm	90	210	490	975	2000	3	1
				120	280	650	1300	2700	4	
				130	280	650	1500	3200	5	
				80	175	340	1300	2600	7	
				90	200	380	1000	2600	8	
				90	200	480	750	1350	10	
				135	220	500	1500	3000	12	
				135	220	500	1500	3000	15	
		150	300	650	2000	3600	16	2		
		150	300	650	2000	3600	20			
		150	300	650	1800	3600	25			
		150	300	650	2000	3600	32			
		150	300	650	1800	3600	40			
		80	200	380	1000	2600	64			
		80	200	480	750	1350	100			

输入转速	Input speeds			PLN070	PLN090	PLN115	PLN142	PLN190	i ⁽¹⁾	z ⁽²⁾
T _{2N} 和 S1 时的平均热输入转速 ⁽⁴⁾⁽⁵⁾	Average thermal input speed at T _{2N} and S1 ⁽⁴⁾⁽⁵⁾	n _{1N}	min ⁻¹	2050 ⁽⁶⁾	1950 ⁽⁶⁾	1500 ⁽⁶⁾	850 ⁽⁶⁾	700 ⁽⁶⁾	3	1
				2300 ⁽⁶⁾	2100 ⁽⁶⁾	1600 ⁽⁶⁾	950 ⁽⁶⁾	750 ⁽⁶⁾	4	
				2650 ⁽⁶⁾	2500 ⁽⁶⁾	2000 ⁽⁶⁾	1050 ⁽⁶⁾	850 ⁽⁶⁾	5	
				3450 ⁽⁶⁾	3550 ⁽⁶⁾	2800 ⁽⁶⁾	1550 ⁽⁶⁾	1200 ⁽⁶⁾	7	
				3800 ⁽⁶⁾	3950 ⁽⁶⁾	3200 ⁽⁶⁾	1800 ⁽⁶⁾	1450 ⁽⁶⁾	8	
				4400 ⁽⁶⁾	4000	3500 ⁽⁶⁾	2250 ⁽⁶⁾	1900 ⁽⁶⁾	10	
				3550 ⁽⁶⁾	3400 ⁽⁶⁾	2450 ⁽⁶⁾	1300 ⁽⁶⁾	1000 ⁽⁶⁾	12	
				4000 ⁽⁶⁾	4000 ⁽⁶⁾	3000 ⁽⁶⁾	1600 ⁽⁶⁾	1250 ⁽⁶⁾	15	
		3800 ⁽⁶⁾	3550 ⁽⁶⁾	2550 ⁽⁶⁾	1350 ⁽⁶⁾	1050 ⁽⁶⁾	16			
		4300 ⁽⁶⁾	4000 ⁽⁶⁾	3050 ⁽⁶⁾	1600 ⁽⁶⁾	1300 ⁽⁶⁾	20			
		4500 ⁽⁶⁾	4000 ⁽⁶⁾	3400 ⁽⁶⁾	1850 ⁽⁶⁾	1400 ⁽⁶⁾	25			
		4500	4000	3500 ⁽⁶⁾	2300 ⁽⁶⁾	1900 ⁽⁶⁾	32			
		4500	4000	3500	2550 ⁽⁶⁾	2100 ⁽⁶⁾	40			
		4500	4000	3500	3000 ⁽⁶⁾	2500 ⁽⁶⁾	64			
		4500	4000	3500	3000	2500	100			
		最高机械输入转速 ⁽⁴⁾	Max. mechanical input speed ⁽⁴⁾	n _{1Limit}	min ⁻¹	14000	10000	8500	6500	6000

⁽¹⁾ 传动比 (i=n₁/n₂)

⁽²⁾ 减速机级数

⁽³⁾ 允许 1000 次

⁽⁴⁾ 利用 NCP 针对应用设计转速- www.neugart.com

⁽⁵⁾ 定义请参见第 128 页

⁽⁶⁾ 在 50% T_{2N} 输出和 S1 模式下的平均热传动转速

⁽¹⁾ Ratios (i=n₁/n₂)

⁽²⁾ Number of stages

⁽³⁾ Permitted 1000 times

⁽⁴⁾ Application-specific speed configurations with NCP – www.neugart.com

⁽⁵⁾ See page 129 for the definition

⁽⁶⁾ Average thermal input speed at 50% T_{2N} and S1

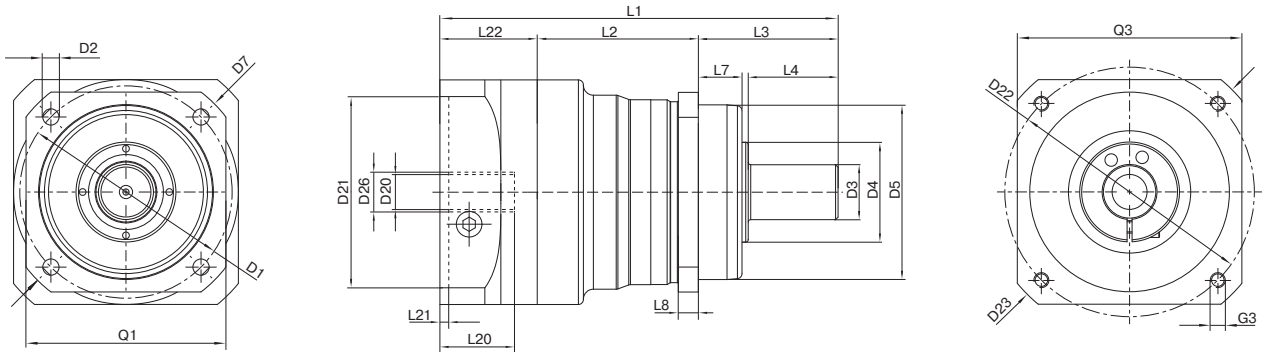

图示为带平键的 PLN090 / 1 级 / 光滑输出轴 / 19 mm 锁紧系统 / 适配电机法兰 – 2 件式 – 圆形通用法兰 / B5 电机法兰类型
 Drawing corresponds to a PLN090 / 1-stage / smooth output shaft / 19 mm clamping system / motor adaptation – 2-part – round universal flange / B5 flange type motor
 所有其它变量可在 www.neugart.com 下 Tec Data Finder 中检索 – All other variants can be retrieved in the Tec Data Finder at www.neugart.com

几何尺寸 ⁽¹⁾	Geometry ⁽¹⁾			PLN070	PLN090	PLN115	PLN142	PLN190	z ⁽²⁾	Code					
输出端安装孔节圆直径	Pitch circle diameter output	D1		68 - 75	85	120	165	215							
输出端安装孔直径	Mounting bore output	D2	4x	5,5	6,5	9,0	11,0	13,5							
输出轴直径	Shaft diameter output	D3	k6	16	22	32	40	55							
输出轴轴肩直径	Shaft collar output	D4		35	40	45	70	80							
输出端定位凸台直径	Centering diameter output	D5	g7	60	70	90	130	160							
输出法兰对角线尺寸	Diagonal dimension output	D7		92	100	140	185	240							
输出端法兰外方	Flange cross section output	Q1	■	70	80	110	142	190							
最小总长	Min. total length	L1		137,5	159,5	201	276	310,5	1						
				166,5	191,5	241	335	382,5	2						
箱体长度	Housing length	L2		59	64,5	61,5	91,5	116	1						
				88	96,5	101,5	150,5	188	2						
输出端定位凸台深度	Centering depth output	L7		19	17,5	28	28	28							
输出端法兰厚度	Flange thickness output	L8		7	8	10	12	15							
输入端锁紧系统直径	Clamping system diameter input	D26		更多信息见第 117 页 More information on page 117											
电机轴直径 j6/k6	Motor shaft diameter j6/k6	D20		具体尺寸视电机/减速机法兰而定。 可以在 www.neugart.com 下 Tec Data Finder. 中针对每个电机适配电机特有的输入法兰几何尺寸 The dimensions vary with the motor/gearbox flange. The input flange geometries can be retrieved for each specific motor in Tec Data Finder at www.neugart.com											
最大允许的电机轴长	Max. permis. motor shaft length	L20													
最小允许的电机轴长	Min. permis. motor shaft length														
输入端定位凹槽直径	Centering diameter input	D21													
输入端定位凹槽深度	Centering depth input	L21													
输入端安装孔节圆直径	Pitch circle diameter input	D22													
输入法兰长度	Motor flange length	L22													
输入法兰对角线尺寸	Diagonal dimension input	D23													
安装螺纹 x 深度	Mounting thread x depth	G3	4x												
输入端法兰外方	Flange cross section input	Q3	■												
附带平键的输出轴 (DIN 6885-1)	Output shaft with feather key (DIN 6885-1)								A 5x5x25	A 6x6x28	A 10x8x50	A 12x8x65	A 16x10x70		
平键宽度 (DIN 6885-1)	Feather key width (DIN 6885-1)	B1							5	6	10	12	16		
含平键在内的轴高 (DIN 6885-1)	Shaft height including feather key (DIN 6885-1)	H1		18	24,5	35	43	59							
输出轴轴长	Shaft length output	L3		48	56	88	110	112		A					
到轴肩的距离	Shaft length from shoulder	L4		28	36	58	80	82							
平键长度	Feather key length	L5		25	28	50	65	70							
到轴端的距离	Distance from shaft end	L6		2	4	4	8	6							
中心孔 (DIN 332, DR 形)	Center hole (DIN 332, type DR)	Z		M5x12,5	M8x19	M12x28	M16x36	M20x42							
光滑输出轴	Smooth output shaft														
输出轴轴长	Shaft length output	L3		48	56	88	110	112		B					
到轴肩的距离	Shaft length from shoulder	L4		28	36	58	80	82							
花键输出轴 (DIN 5480)	Toothed output shaft (DIN 5480)			W16x0,8x18x6m	W22x1,25x16x6m	W32x1,25x24x6m	W40x2,0x18x6m	W55x2,0x26x6m							
花键或键槽的长度	Width of gearing	L _v		15	15	15	20	22							
输出轴轴长	Shaft length output	L3		46	46	56	70	72		C					
到轴肩的距离	Shaft length from shoulder	L4		26	26	26	40	41,5							
中心孔 (DIN 332, DR 形)	Center hole (DIN 332, type DR)	Z		M5x12,5	M8x19	M12x28	M16x36	M20x42							

⁽¹⁾ 所有的尺寸单位为mm
⁽²⁾ 减速机级数

⁽¹⁾ Dimensions in mm
⁽²⁾ Number of stages

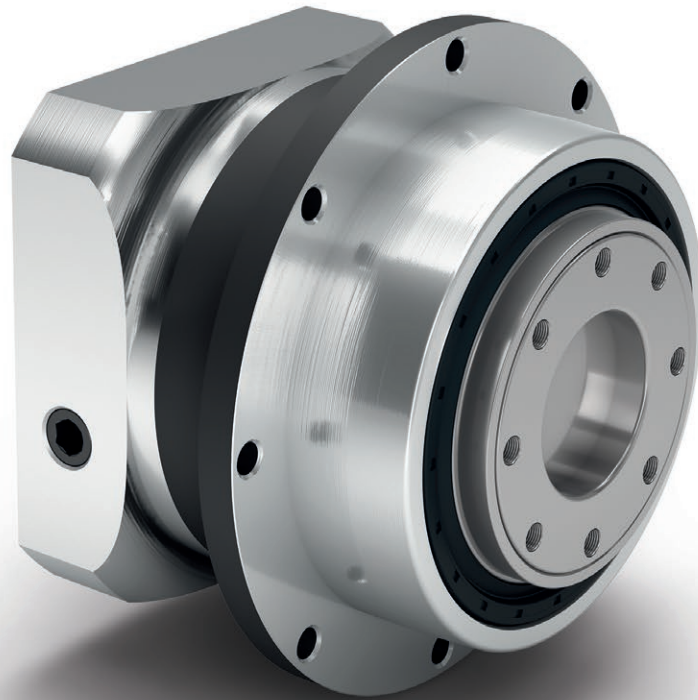

PSFN

负载量最高的精密减速机 运行时十分安静 采用法兰输出轴

由于采用了标准化的法兰界面，**PSFN** 的安装非常便捷安全。我们研发的高精度斜齿轮让其他降噪措施毫无用武之地。由于其抗倾斜力矩很高，这款高精度行星减速机可以完成许多高难度任务。

The precision planetary gearbox for maximum loads with particularly quiet drive and flange output shaft

Thanks to its standardized flange interface, our **PSFN** can be installed easily and reliably. Our Neugart-designed helical teeth makes additional noise absorption measures absolute. Thanks to its high tilting moment, you may demand the utmost from this precision planetary gearbox.

- ⊕ 回程间隙极小，精度极高 (< 1 弧分)
- ⊕ 可安装在任意位置
- ⊕ 输入法兰可适配特殊的电机
- ⊕ 终生润滑，因此免维护
- ⊕ 旋转方向同向
- ⊕ 优化转动惯量的锁紧系统

- ⊕ Minimized backlash for maximized precision (< 1 arcmin)
- ⊕ For any mounting position
- ⊕ Individual adaptation of the input flange to the motor
- ⊕ Lifetime lubrication for maintenance-free operation
- ⊕ Equidirectional rotation
- ⊕ Clamping systems with optimized mass moment of inertia

① 便捷、安全、迅速

由于采用了符合 EN ISO 9409-1 要求的标准化法兰界面，**PSFN** 驱动组件（如法兰齿轮、皮带盘或转盘给料机）的安装十分迅速便捷。选配的定位销孔还为固定时的安全性提供了额外的保障。

② 运行十分安静

PSFN 在运行时十分安静。由于采用了我们研发的高精度斜齿设计，便无需在机器上采取各种隔音措施。这样就能降低成本。

③ 负载能力极高

由于其抗倾斜力矩很高，**PSFN** 能够承受极高的轴向力和径向力。这在为转台或齿轮-齿条应用进行结构设计时能够发挥极大的作用。当然，其性能不会受到任何影响。

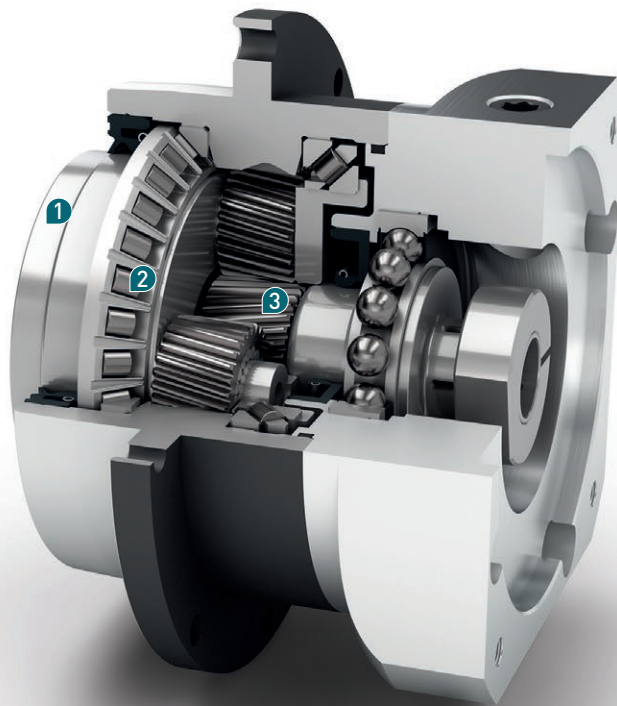

① Easy, reliable, fast

Fitted with an EN ISO 9409-1 flange interface, the **PSFN** lets you install drive components quickly and easily like flange pinion, pulley, or turntable. The optional dowel hole provides additional secureness during fitting.

② Particularly quiet drive

The **PSFN** runs particularly quiet. Thanks to the helical teeth we have developed, you need not think about noise absorption measures for your machine. This saves you money.

③ Maximized loads

Thanks to its high tilting moment, you can subject the **PSFN** to the highest radial and axial forces. This has genuine benefits for the design of turntables or rack and pinion assemblies – and all this, of course, with the best performance.

Code	减速机参数	Gearbox characteristics			PSFN064	PSFN090	PSFN110	PSFN140	PSFN200	z ⁽¹⁾	
	使用寿命	Service life	t _L	h	20.000						
	T _{2N} × 0.88 时的使用寿命	Service life at T _{2N} × 0.88			30.000						
	满载时效率 ⁽²⁾	Efficiency at full load ⁽²⁾	η	%	97						1
					96						2
	最低工作温度	Min. operating temperature	T _{min}	°C	-25						
	最高工作温度	Max. operating temperature	T _{max}		90						
防护等级	Protection class			IP 65							
S	标准润滑	Standard lubrication			润滑油 / Oil						
F	食品级润滑	Food grade lubrication			润滑油 / Oil						
L	低温润滑 ⁽³⁾	Low temperature lubrication ⁽³⁾			润滑油 / Oil						
	安装位置	Installation position			任意 / Any						
S	标准回程间隙	Standard backlash	j _t	arcmin	< 3					1	
					< 5					2	
R	降低回程间隙	Reduced backlash	c _g	Nm / arcmin	< 2	< 1	< 1	< 1	< 1		
					8,9	24,5	61,0	142,0	455,0	1	
					12,0	33,0	82,0	190,0	610,0		
					9,1	24,0	60,0	139,0	445,0	2	
					12,0	31,5	79,0	182,0	585,0		
	减速机重量	Gearbox weight	m _G	kg	1,5	3	6,5	12	28,3	1	
					2,2	4	8	13,5	32	2	
S	标准的箱体表面	Standard surface			箱体: 钢 - 氮碳共渗和后氧化处理 (黑色) Housing: Steel - nitrocarburized and post-oxidized (black)						
	运行噪音 ⁽⁴⁾	Running noise ⁽⁴⁾	Q _g	dB(A)	57	58	63	66	68		
	基于减速机输入法兰的最大弯矩 ⁽⁵⁾	Max. bending moment based on the gearbox input flange ⁽⁵⁾	M _b	Nm	18	38	80	180	300	1	
					18	18	38	80	180	2	
	电机法兰精度	Motor flange precision			DIN 42955-R						

输出轴载荷	Output shaft loads			PSFN064	PSFN090	PSFN110	PSFN140	PSFN200	z ⁽¹⁾
20,000 h 的径向力 ⁽⁶⁾⁽⁷⁾	Radial force for 20,000 h ⁽⁶⁾⁽⁷⁾	F _{r20.000h}	N	2400	4400	5500	12000	23000	
20,000 h 的轴向力 ⁽⁶⁾⁽⁷⁾	Axial force for 20,000 h ⁽⁶⁾⁽⁷⁾	F _{a20.000h}		4300	8200	9500	8500	16000	
30,000 h 的径向力 ⁽⁶⁾⁽⁷⁾	Radial force for 30,000 h ⁽⁶⁾⁽⁷⁾	F _{r30.000h}		2100	3900	4800	11000	21000	
30,000 h 的轴向力 ⁽⁶⁾⁽⁷⁾	Axial force for 30,000 h ⁽⁶⁾⁽⁷⁾	F _{a30.000h}		3800	7200	8400	7500	14000	
静态径向力 ⁽⁷⁾⁽⁸⁾	Static radial force ⁽⁷⁾⁽⁸⁾	F _{rStat}		2400	4400	5500	12000	23000	
静态轴向力 ⁽⁷⁾⁽⁸⁾	Static axial force ⁽⁷⁾⁽⁸⁾	F _{aStat}		4300	8200	9500	8500	16000	
20,000 h 倾斜力矩 ⁽⁶⁾⁽⁸⁾	Tilting moment for 20,000 h ⁽⁶⁾⁽⁸⁾	M _{K20.000h}	Nm	147	361	534	1030	2445	
30,000 h 倾斜力矩 ⁽⁶⁾⁽⁸⁾	Tilting moment for 30,000 h ⁽⁶⁾⁽⁸⁾	M _{K30.000h}		129	320	466	944	2232	

转动惯量	Moment of inertia			PSFN064	PSFN090	PSFN110	PSFN140	PSFN200	z ⁽¹⁾
转动惯量 ⁽²⁾	Mass moment of inertia ⁽²⁾	J	kgcm ²	0,128	0,342	0,892	6,526	22,520	1
				0,188	0,611	1,741	9,670	40,642	
				0,124	0,125	0,325	0,853	6,434	2
				0,180	0,197	0,587	1,836	10,410	

(1) 减速机级数
 (2) 传动比相关的数值可在 Tec Data Finder 中检索 - www.neugart.com
 (3) T_{min} = -40°C. 理想运行温度最高为 50°C
 (4) 距离减速机 1 m 时; 在输入转速为 n₁=3000 min⁻¹ 且无负荷时测得; i=5
 (5) 最大发动机重量* (单位: kg) = 0.2 × M_b / 发动机长度 (单位: m)
 * 发动机重量对称分布
 * 水平和固定的安装位置
 (6) 数据以 n₂=100 min⁻¹ 的输出轴转速为准。
 (7) 基于输出轴末端
 (8) 更改 T_{2N}, F_r, F_a 以及周期和轴承使用寿命时, 数值存在偏差 (部分较高)。利用 NCP 针对应用进行专门设计 - www.neugart.com

(1) Number of stages
 (2) The ratio-dependent values can be retrieved in Tec Data Finder - www.neugart.com
 (3) T_{min} = -40°C. Optimal operating temperature max. 50°C
 (4) Sound pressure level from 1 m, measured on input running at n₁=3000 rpm no load; i=5
 (5) Max. motor weight* in kg = 0.2 × M_b / motor length in m
 * with symmetrically distributed motor weight
 * with horizontal and stationary mounting
 (6) These values are based on an output shaft speed of n₂=100 rpm
 (7) Based on the end of the output shaft
 (8) Other (sometimes higher) values following changes to T_{2N}, F_r, F_a, cycle, and service life of bearing. Application specific configuration with NCP - www.neugart.com

输出扭矩	Output torques			PSFN064	PSFN090	PSFN110	PSFN140	PSFN200	$i^{(1)}$	$z^{(2)}$					
额定输出扭矩 ⁽³⁾	Nominal output torque ⁽³⁾	T_{2N}	Nm	39	80	180	470	950	4	1					
				40	80	175	405	950	5						
				37	78	175	355	900	7						
				28	59	140	305	750	10						
				39	80	180	450	950	16	2					
				39	80	180	450	950	20						
				40	80	175	405	950	25						
				40	80	175	405	950	35						
				39	80	180	470	950	40						
				40	80	175	405	950	50						
				37	78	175	355	900	70						
				28	59	140	305	750	100						
				最大输出扭矩 ⁽⁴⁾	Max. output torque ⁽⁴⁾	T_{2max}	Nm	62	128		288	752	1520	4	1
								64	128		280	648	1520	5	
59	125	280	568					1440	7						
45	94	224	488					1200	10						
62	128	288	720					1520	16	2					
62	128	288	720					1520	20						
64	128	280	648					1520	25						
64	128	280	648					1520	35						
62	128	288	752					1520	40						
64	128	280	648					1520	50						
59	125	280	568					1440	70						
45	94	224	488					1200	100						

⁽¹⁾ 传动比 ($i=n_1/n_2$)⁽²⁾ 减速机级数⁽³⁾ 利用 NCP 针对应用进行专门设计 – www.neugart.com⁽⁴⁾ 允许输出轴转动30,000转; 参见第 128 页⁽¹⁾ Ratios ($i=n_1/n_2$)⁽²⁾ Number of stages⁽³⁾ Application specific configuration with NCP – www.neugart.com⁽⁴⁾ 30,000 rotations of the output shaft permitted; see page 129

输出扭矩	Output torques			PSFN064	PSFN090	PSFN110	PSFN140	PSFN200	i ⁽¹⁾	z ⁽²⁾		
急停扭矩 ⁽³⁾	Emergency stop torque ⁽³⁾	T _{2Stop}	Nm	120	280	650	1650	3200	4	1		
				130	280	650	1650	3200	5			
				80	175	340	1300	3200	7			
				90	200	480	600	1700	10			
				150	300	650	1650	3200	16			
				150	300	650	1650	3200	20			
						150	300	650	1650	3200	25	2
						150	300	650	1650	3200	35	
						150	300	650	1650	3200	40	
						150	300	650	1650	3200	50	
						80	175	340	1300	3200	70	
						90	200	480	600	1700	100	

输入转速	Input speeds			PSFN064	PSFN090	PSFN110	PSFN140	PSFN200	i ⁽¹⁾	z ⁽²⁾		
T _{2N} 和 S1 时的平均热输入转速 ⁽⁴⁾⁽⁵⁾	Average thermal input speed at T _{2N} and S1 ⁽⁴⁾⁽⁵⁾	n _{1N}	min ⁻¹	3200 ⁽⁶⁾	2400 ⁽⁶⁾	1800 ⁽⁶⁾	1100 ⁽⁶⁾	750 ⁽⁶⁾	4	1		
				3800 ⁽⁶⁾	2950 ⁽⁶⁾	2250 ⁽⁶⁾	1350 ⁽⁶⁾	950 ⁽⁶⁾	5			
				4500	3800 ⁽⁶⁾	2950 ⁽⁶⁾	1800 ⁽⁶⁾	1250 ⁽⁶⁾	7			
				4500	4000	3500	2300 ⁽⁶⁾	1700 ⁽⁶⁾	10			
				4500	4500	3800 ⁽⁶⁾	2450 ⁽⁶⁾	1550 ⁽⁶⁾	16			
				4500	4500	4000	3050 ⁽⁶⁾	1900 ⁽⁶⁾	20			
						4500	4500	4000	3350 ⁽⁶⁾	2050 ⁽⁶⁾	25	2
						4500	4500	4000	3500	2650 ⁽⁶⁾	35	
						4500	4500	4000	3500	3000 ⁽⁶⁾	40	
						4500	4500	4000	3500	3000	50	
						4500	4500	4000	3500	3000	70	
						4500	4500	4000	3500	3000	100	
						最高机械输入转速 ⁽⁴⁾	Max. mechanical input speed ⁽⁴⁾	n _{1Limit}	min ⁻¹	14000	10000	
14000	14000	10000	8500	6500						2		

⁽¹⁾ 传动比 (i=n₁/n₂)

⁽²⁾ 减速机级数

⁽³⁾ 允许 1000 次

⁽⁴⁾ 利用 NCP 针对应用设计转速- www.neugart.com

⁽⁵⁾ 定义请参见第 128 页

⁽⁶⁾ 在 50% T_{2N} 输出和 S1 模式下的平均热传动转速

⁽¹⁾ Ratios (i=n₁/n₂)

⁽²⁾ Number of stages

⁽³⁾ Permitted 1000 times

⁽⁴⁾ Application-specific speed configurations with NCP – www.neugart.com

⁽⁵⁾ See page 129 for the definition

⁽⁶⁾ Average thermal input speed at 50% T_{2N} and S1

PSFN064
PSFN090

PSFN110

PSFN140
PSFN200

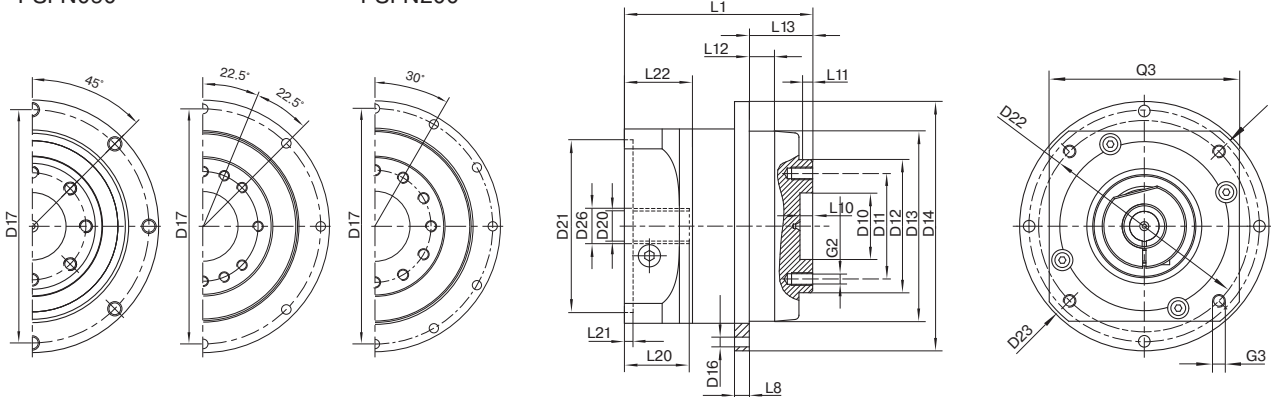

图示为带平键的 PSFN090 / 1 级 / 法兰输出轴 / 14 mm 锁紧系统 / 适配电机法兰 - 2 件式 - 形通用法兰 / B5 电机法兰类型
 Drawing corresponds to a PSFN090 / 1-stage / flange output shaft / 14 mm clamping system / motor adaptation - 2-part - round universal flange / B5 flange type motor
 所有其它变量可在 www.neugart.com 下 Tec Data Finder 中检索 - All other variants can be retrieved in the Tec Data Finder at www.neugart.com

几何尺寸 ⁽¹⁾	Geometry ⁽¹⁾			PSFN064	PSFN090	PSFN110	PSFN140	PSFN200	z ⁽²⁾	Code
输出端定位凹槽直径	Centering diameter output shaft	D10	H7	20	31,5	40	50	80		
输出端安装孔节圆直径	Pitch circle Ø output shaft	D11		31,5	50	63	80	125		
输出轴定位凸台直径	Centering diameter output shaft	D12	h7	40	63	80	100	160		
输出法兰定位凸台直径	Centering Ø output flange	D13		64	90	110	140	200		
输出法兰直径	Flange diameter output	D14		86	118	145	179	247		
输出端安装孔直径	Mounting bore output	D16		4,5 8x45°	5,5 8x45°	5,5 8x45°	6,6 12x30°	9 12x30°		
输出法兰安装孔节圆直径	Pitch circle Ø output flange	D17		79	109	135	168	233		
最小总长	Min. total length	L1		71	89,5	108	142	172	1	
				99,5	111,5	130	173	217	2	
输出端法兰厚度	Flange thickness output	L8		4	7	8	10	12		
输出轴定位凸台深度	Centering depth output shaft	L10		4,5	6,5	6,5	6,5	10		
	Centering depth output shaft	L11		3	6	6	6	7		
输出法兰定位凸台深度	Centering depth output flange	L12		10	12	12	14	17,5		
输出法兰长度	Output flange length	L13		19,5	30,0	29,0	38,0	50,0		
输入端锁紧系统直径	Clamping system diameter input	D26		更多信息见第 117 页 More information on page 117						
电机轴直径 j6/k6	Motor shaft diameter j6/k6	D20		具体尺寸视电机/减速机法兰而定。 可以在 www.neugart.com 下 Tec Data Finder. 中针对每个电机适配电机特有的输入法兰几何尺寸 The dimensions vary with the motor/gearbox flange. The input flange geometries can be retrieved for each specific motor in Tec Data Finder at www.neugart.com						
最大允许的电机轴长	Max. permis. motor shaft length	L20								
最小允许的电机轴长	Min. permis. motor shaft length									
输入端定位凹槽直径	Centering diameter input	D21								
输入端定位凹槽深度	Centering depth input	L21								
输入端安装孔节圆直径	Pitch circle diameter input	D22								
输入法兰长度	Motor flange length	L22								
输入法兰对角线尺寸	Diagonal dimension input	D23								
安装螺纹 x 深度	Mounting thread x depth	G3	4x							
输入端法兰外方	Flange cross section input	Q3	■							
法兰输出轴 (相似的 EN ISO 9409-1)	Flange output shaft (similar EN ISO 9409-1)									D
数量 x 螺纹 x 深度	Number x thread x depth	G2		8 x M5x7	8 x M6x10	12 x M6x12	12 x M8x15	12 x M10x20		
带有配合销孔的法兰输出轴 (EN ISO 9409-1)	Flange output shaft with dowel hole (EN ISO 9409-1)									E
配合销孔 x 深度	Dowel hole x depth	D15	H7	5x5	6x6	6x6	8x8	10x10		
数量 x 螺纹 x 深度	Number x thread x depth	G2		7 x M5x7	7 x M6x10	11 x M6x12	11 x M8x15	11 x M10x20		

⁽¹⁾ 所有的尺寸单位为mm
⁽²⁾ 减速机级数

⁽¹⁾ Dimensions in mm
⁽²⁾ Number of stages

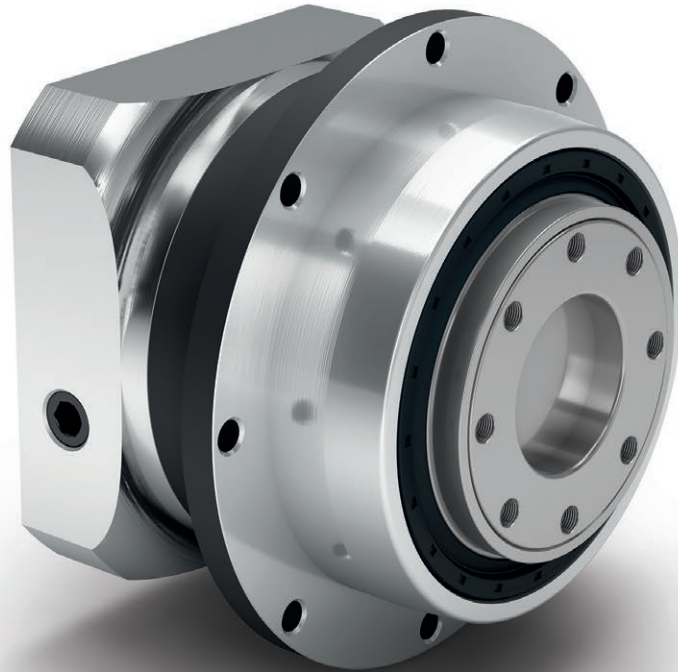

PLFN

负载极大的精密减速机 且性能极高 安装便捷

PLFN 配有标准化的法兰接口，因此安装简便。这款直齿高精度行星减速机适用于需实现最高效能和扭矩的应用情况。其倾斜力矩很高，即使轴向和径向力极高，也能有出色表现。

The precision planetary gearbox for maximum loads and the highest performance – fast and easy to install

Our **PLFN** features a standardized flange interface for ease of installation. The straight-teeth precision planetary gearbox has been designed for the highest performance and torque. Its high tilting moment delivers the best performance even under the highest radial and axial forces.

- ⊕ 回程间隙极小，精度极高 (< 1 弧分)
- ⊕ 可安装在任意位置
- ⊕ 输入法兰可适配特殊的电机
- ⊕ 经过终生润滑，因此免维护
- ⊕ 旋转方向同向
- ⊕ 优化转动惯量的锁紧系统

- ⊕ Minimized backlash for maximized precision (< 1 arcmin)
- ⊕ For any mounting position
- ⊕ Individual adaptation of the input flange to the motor
- ⊕ Lifetime lubrication for maintenance-free operation
- ⊕ Equidirectional rotation
- ⊕ Clamping systems with optimized mass moment of inertia

1 标准化法兰接口

PLFN 高精度减速机配有符合 EN ISO 9409-1 标准的标准化接口，因此驱动组件（如法兰齿轮、皮带盘或转盘给料机）的安装十分简便安全。选配的定位销孔还为固定时的安全性提供了额外的保障。

2 负载能力极高

由于其抗倾斜力矩很高，因此 **PLFN** 十分坚固，能承受住极高的轴向和径向力。这是针对高标准应用（如转向台或齿轮-齿条应用）的高科技技术。

3 扭矩极高

PLFN 配有直齿轮，适用于高效能应用。由于其智能化设计，该款产品扭矩比传统行星减速机更高。

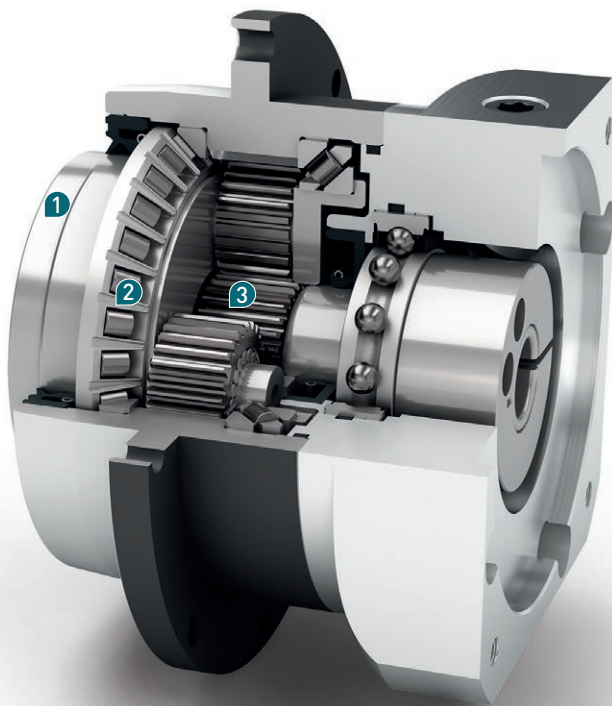

1 Standardized flange interface

Fitted with an EN ISO 9409-1 interface, the **PLFN** precision planetary gearbox promises you fast and easy installation of the drive components like flange pinion, pulley, or turntable. The optional dowel hole provides additional secureness during fitting.

2 Maximized loads

Thanks to its high tilting moment, the **PLFN** is particularly robust and withstands even the highest axial and radial forces. This advanced technology is intended for your complex applications, e.g. turntable or rack and pinion.

3 Maximized torque

Thanks to its straight teeth, the **PLFN** is ideal for the highest performance. Its intelligent design delivers greater power than conventional planetary gearboxes.

Code	减速机参数	Gearbox characteristics			PLFN064	PLFN090	PLFN110	PLFN140	PLFN200	z ⁽¹⁾		
	使用寿命	Service life	t _L	h	20.000							
	T _{2N} × 0.88 时的使用寿命	Service life at T _{2N} × 0.88			30.000							
	满载时效率 ⁽²⁾	Efficiency at full load ⁽²⁾	η	%	97							
					96							
	最低工作温度	Min. operating temperature	T _{min}	°C	-25							
	最高工作温度	Max. operating temperature	T _{max}		90							
	防护等级	Protection class	IP 65									
S	标准润滑	Standard lubrication	润滑油 / Oil									
F	食品级润滑	Food grade lubrication	润滑油 / Oil									
L	低温润滑 ⁽³⁾	Low temperature lubrication ⁽³⁾	润滑油 / Oil									
	安装位置	Installation position	任意 / Any									
S	标准回程间隙	Standard backlash	j _t	arcmin	< 3							
					< 5							
R	降低回程间隙	Reduced backlash	<table border="1"> <tr> <td>< 2</td> <td>< 1</td> <td>< 1</td> <td>< 1</td> <td>< 1</td> </tr> </table>					< 2	< 1	< 1	< 1	< 1
< 2	< 1	< 1	< 1	< 1								
	抗扭刚度 ⁽²⁾	Torsional stiffness ⁽²⁾	C _g	Nm / arcmin	10,8	25,5	64,0	145,0	470,0	1		
					14,5	34,0	86,0	195,0	630,0			
					11,0	25,0	63,0	142,0	460,0			
					14,5	32,5	83,0	187,0	605,0			
	减速机重量	Gearbox weight	m _G	kg	1,5	3	6,5	13,8	35,5	1		
					2,2	4	8	16	42,5	2		
S	标准的箱体表面	Standard surface	Gehäuse: Stahl – nitrocarburisiert und nachoxidiert (schwarz) Housing: Steel – nitrocarburized and post-oxidized (black)									
	运行噪音 ⁽⁴⁾	Running noise ⁽⁴⁾	Q _g	dB(A)	60	62	65	70	74			
	基于减速机输入法兰的最大弯矩 ⁽⁵⁾	Max. bending moment based on the gearbox input flange ⁽⁵⁾	M _b	Nm	18	38	80	180	300			
					18	18	38	80	180			
	电机法兰精度	Motor flange precision	DIN 42955-R									

输出轴载荷	Output shaft loads			PLFN064	PLFN090	PLFN110	PLFN140	PLFN200	z ⁽¹⁾
20,000 h 的径向力 ⁽⁶⁾⁽⁷⁾	Radial force for 20,000 h ⁽⁶⁾⁽⁷⁾	F _{r20.000h}	N	2400	4400	5500	12000	33000	
20,000 h 的轴向力 ⁽⁶⁾⁽⁷⁾	Axial force for 20,000 h ⁽⁶⁾⁽⁷⁾	F _{a20.000h}		4300	8200	9500	8500	15000 ⁽⁸⁾	
30,000 h 的径向力 ⁽⁶⁾⁽⁷⁾	Radial force for 30,000 h ⁽⁶⁾⁽⁷⁾	F _{r30.000h}		2100	3900	4800	11000	29500	
30,000 h 的轴向力 ⁽⁶⁾⁽⁷⁾	Axial force for 30,000 h ⁽⁶⁾⁽⁷⁾	F _{a30.000h}		3800	7200	8400	7500	13500 ⁽⁸⁾	
静态径向力 ⁽⁷⁾⁽⁸⁾	Static radial force ⁽⁷⁾⁽⁸⁾	F _{rStat}		2400	4400	5500	12000	33000	
静态轴向力 ⁽⁷⁾⁽⁸⁾	Static axial force ⁽⁷⁾⁽⁸⁾	F _{aStat}		4300	8200	9500	8500	15000 ⁽⁸⁾	
20,000 h 倾斜力矩 ⁽⁶⁾⁽⁸⁾	Tilting moment for 20,000 h ⁽⁶⁾⁽⁸⁾	M _{K20.000h}	Nm	148	363	534	1219	4957	
30,000 h 倾斜力矩 ⁽⁶⁾⁽⁸⁾	Tilting moment for 30,000 h ⁽⁶⁾⁽⁸⁾	M _{K30.000h}		129	322	466	1117	4431	

转动惯量	Moment of inertia			PLFN064	PLFN090	PLFN110	PLFN140	PLFN200	z ⁽¹⁾
转动惯量 ⁽²⁾	Mass moment of inertia ⁽²⁾	J	kgcm ²	0,217	0,580	2,036	7,313	26,880	1
				0,288	0,920	2,942	12,365	61,170	
				0,209	0,211	0,546	1,947	6,896	
				0,243	0,269	0,737	2,760	11,720	

(1) 减速机级数
 (2) 传动比相关的数值可在 Tec Data Finder 中检索 – www.neugart.com
 (3) T_{min} = -40°C. 理想运行温度最高为 50°C
 (4) 距离减速机 1 m 时; 在输入转速为 n₁=3000 min⁻¹ 且无负荷时测得; i=5
 (5) 最大发动机重量* (单位: kg) = 0.2 × M_b / 发动机长度 (单位: m)
 * 发动机重量对称分布
 * 水平和固定的安装位置
 (6) 数据以 n₂=100 min⁻¹ 的输出轴转速为准。
 (7) 基于输出轴末端
 (8) 更改 T_{2N}, F_r, F_a 以及周期和轴承使用寿命时, 数值存在偏差 (部分较高)。利用 NCP 针对应用进行专门设计 – www.neugart.com

(1) Number of stages
 (2) The ratio-dependent values can be retrieved in Tec Data Finder – www.neugart.com
 (3) T_{min} = -40°C. Optimal operating temperature max. 50°C
 (4) Sound pressure level from 1 m, measured on input running at n₁=3000 rpm no load; i=5
 (5) Max. motor weight* in kg = 0.2 × M_b / motor length in m
 * with symmetrically distributed motor weight
 * with horizontal and stationary mounting
 (6) These values are based on an output shaft speed of n₂=100 rpm
 (7) Based on the end of the output shaft
 (8) Other (sometimes higher) values following changes to T_{2N}, F_r, F_a, cycle, and service life of bearing. Application specific configuration with NCP – www.neugart.com

输出扭矩	Output torques			PLFN064	PLFN090	PLFN110	PLFN140	PLFN200	i ⁽¹⁾	z ⁽²⁾
额定输出扭矩 ⁽³⁾	Nominal output torque ⁽³⁾	T _{2N}	Nm	60	140	300	600	1300	4	1
				65	140	260	750	1600	5	
				45	90	180	530	1300	7	
				40	80	150	450	1000	8	
				27	60	125	305	630	10	
				77	150	300	1000	1800	16	
				77	150	300	1000	1800	20	2
				65	140	260	900	1800	25	
				77	150	300	600	1800	32	
				65	140	260	750	1800	40	
				65	130	260	620	1525	50	
				40	80	150	450	1000	64	
				27	60	125	305	630	100	
				96	224	480	960	2080	4	
104	224	416	1200	2560	5					
72	144	288	848	2080	7					
64	128	240	720	1600	8					
43	96	200	488	1008	10					
123	240	480	1600	2880	16	2				
123	240	480	1600	2880	20					
104	224	416	1440	2880	25					
123	240	480	960	2880	32					
104	224	416	1200	2880	40					
104	208	416	992	2440	50					
64	128	240	720	1600	64					
43	96	200	488	1008	100					

⁽¹⁾ 传动比 (i=n₁/n₂)

⁽²⁾ 减速机级数

⁽³⁾ 利用 NCP 针对应用进行专门设计 – www.neugart.com

⁽⁴⁾ 允许输出轴转动30,000转; 参见第 128 页

⁽¹⁾ Ratios (i=n₁/n₂)

⁽²⁾ Number of stages

⁽³⁾ Application specific configuration with NCP – www.neugart.com

⁽⁴⁾ 30,000 rotations of the output shaft permitted; see page 129

输出扭矩	Output torques			PLFN064	PLFN090	PLFN110	PLFN140	PLFN200	i ⁽¹⁾	z ⁽²⁾
急停扭矩 ⁽³⁾	Emergency stop torque ⁽³⁾	T _{2Stop}	Nm	120	280	650	1300	2700	4	1
				130	280	650	1500	3200	5	
				90	175	340	1300	2600	7	
				90	200	380	1000	2600	8	
				90	200	480	750	1350	10	
				150	300	650	2000	3600	16	2
				150	300	650	2000	3600	20	
				150	300	650	1800	3600	25	
				150	300	650	1500	3600	32	
				150	300	650	1500	3600	40	
				150	300	650	1500	3600	50	
				80	200	380	1000	2600	64	
				80	200	480	750	1350	100	

输入转速	Input speeds			PLFN064	PLFN090	PLFN110	PLFN140	PLFN200	i ⁽¹⁾	z ⁽²⁾
T _{2N} 和 S1 时的平均热输入转速 ⁽⁴⁾⁽⁵⁾	Average thermal input speed at T _{2N} and S1 ⁽⁴⁾⁽⁵⁾	n _{1N}	min ⁻¹	2100 ⁽⁶⁾	1750 ⁽⁶⁾	1300 ⁽⁶⁾	850 ⁽⁶⁾	500 ⁽⁶⁾	4	1
				2450 ⁽⁶⁾	2100 ⁽⁶⁾	1650 ⁽⁶⁾	950 ⁽⁶⁾	600 ⁽⁶⁾	5	
				3200 ⁽⁶⁾	3000 ⁽⁶⁾	2350 ⁽⁶⁾	1400 ⁽⁶⁾	850 ⁽⁶⁾	7	
				3550 ⁽⁶⁾	3350 ⁽⁶⁾	2650 ⁽⁶⁾	1650 ⁽⁶⁾	1000 ⁽⁶⁾	8	
				4100 ⁽⁶⁾	4000 ⁽⁶⁾	3150 ⁽⁶⁾	2050 ⁽⁶⁾	1300 ⁽⁶⁾	10	
				3700 ⁽⁶⁾	3850 ⁽⁶⁾	3150 ⁽⁶⁾	1700 ⁽⁶⁾	1100 ⁽⁶⁾	16	2
				4200 ⁽⁶⁾	4450 ⁽⁶⁾	3750 ⁽⁶⁾	2100 ⁽⁶⁾	1350 ⁽⁶⁾	20	
				4500 ⁽⁶⁾	4500 ⁽⁶⁾	4000 ⁽⁶⁾	2500 ⁽⁶⁾	1550 ⁽⁶⁾	25	
				4500 ⁽⁶⁾	4500	4000	3500 ⁽⁶⁾	2000 ⁽⁶⁾	32	
				4500	4500	4000	3500 ⁽⁶⁾	2250 ⁽⁶⁾	40	
				4500	4500	4000	3500	2750 ⁽⁶⁾	50	
				4500	4500	4000	3500	3000 ⁽⁶⁾	64	
				4500	4500	4000	3500	3000	100	
				最高机械输入转速 ⁽⁴⁾	Max. mechanical input speed ⁽⁴⁾	n _{1Limit}	min ⁻¹	14000	10000	
14000	14000	10000	8500					6500		2

⁽¹⁾ 传动比 (i=n₁/n₂)

⁽²⁾ 减速机级数

⁽³⁾ 允许 1000 次

⁽⁴⁾ 利用 NCP 针对应用设计转速 - www.neugart.com

⁽⁵⁾ 定义请参见第 128 页

⁽⁶⁾ 在 50% T_{2N} 输出和 S1 模式下的平均热传动转速

⁽¹⁾ Ratios (i=n₁/n₂)

⁽²⁾ Number of stages

⁽³⁾ Permitted 1000 times

⁽⁴⁾ Application-specific speed configurations with NCP - www.neugart.com

⁽⁵⁾ See page 129 for the definition

⁽⁶⁾ Average thermal input speed at 50% T_{2N} and S1

PLFN064
PLFN090

PLFN110

PLFN140
PLFN200

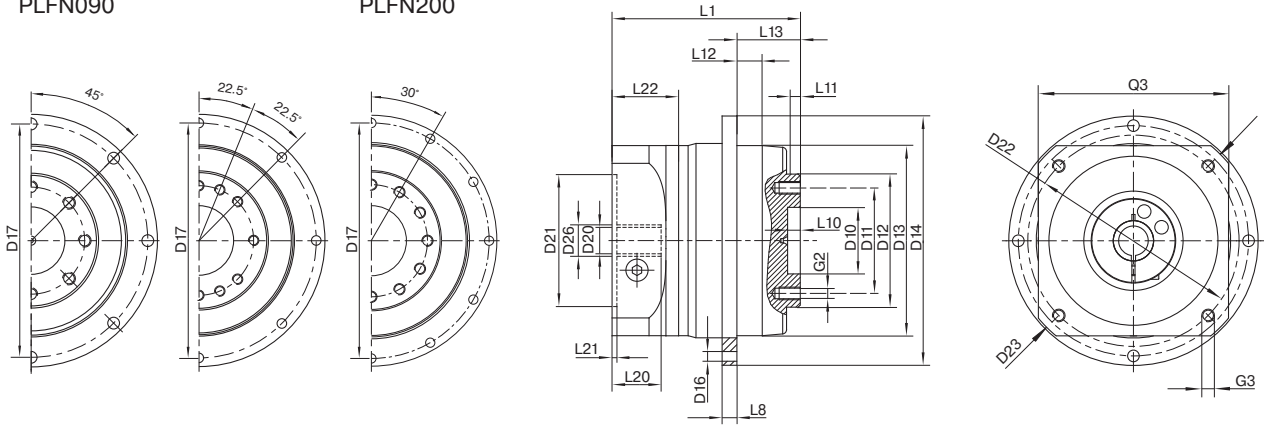

图示为带平键的 PLFN090 / 1 级 / 法兰输出轴 / 19 mm 锁紧系统 / 适配电机法兰 - 2 件式 - 圆形通用法兰 / B5 电机法兰类型
 Drawing corresponds to a PLFN090 / 1-stage / flange output shaft / 19 mm clamping system / motor adaptation - 2-part - round universal flange / B5 flange type motor
 所有其它变量可在 www.neugart.com 下 Tec Data Finder 中检索 - All other variants can be retrieved in the Tec Data Finder at www.neugart.com

几何尺寸 ⁽¹⁾	Geometry ⁽¹⁾			PLFN064	PLFN090	PLFN110	PLFN140	PLFN200	z ⁽²⁾	Code
输出端定位凹槽直径	Centering Ø output shaft	D10	H7	20	31,5	40	50	80		
输出端安装孔节圆直径	Pitch circle Ø output shaft	D11		31,5	50	63	80	125		
输出轴定位凸台直径	Centering Ø output shaft	D12	h7	40	63	80	100	160		
输出法兰定位凸台直径	Centering Ø output flange	D13		64	90	110	140	200		
输出法兰直径	Flange diameter output	D14		86	118	145	179	247		
输出端安装孔直径	Mounting bore output	D16		4,5 8x45°	5,5 8x45°	5,5 8x45°	6,6 12x30°	9 12x30°		
输出法兰安装孔节圆直径	Pitch circle Ø output flange	D17		79	109	135	168	233		
最小总长	Min. total length	L1		71	89	108	157	212,5	1	
				99,5	111	130	187,5	264	2	
输出端法兰厚度	Flange thickness output	L8		4	7	8	10	12		
输出轴定位凸台深度	Centering depth output shaft	L10		4,5	6,5	6,5	6,5	10		
	Centering depth output shaft	L11		3	6	6	6	8		
输出法兰定位凸台深度	Centering depth output flange	L12		10	12	12	14	17,5		
输出法兰长度	Output flange length	L13		19,5	30,0	29,0	38,0	50,0		
输入端锁紧系统直径	Clamping system diameter input	D26		更多信息见第 117 页 More information on page 117						
电机轴直径 j6/k6	Motor shaft diameter j6/k6	D20		具体尺寸视电机/减速机法兰而定。 可以在 www.neugart.com 下 Tec Data Finder. 中针对每个电机适配电机特有的输入法兰几何尺寸 The dimensions vary with the motor/gearbox flange. The input flange geometries can be retrieved for each specific motor in Tec Data Finder at www.neugart.com						
最大允许的电机轴长	Max. permis. motor shaft length	L20								
最小允许的电机轴长	Min. permis. motor shaft length									
输入端定位凹槽直径	Centering diameter input	D21								
输入端定位凹槽深度	Centering depth input	L21								
输入端安装孔节圆直径	Pitch circle diameter input	D22								
输入法兰长度	Motor flange length	L22								
输入法兰对角线尺寸	Diagonal dimension input	D23								
安装螺纹 x 深度	Mounting thread x depth	G3	4x							
输入端法兰外方	Flange cross section input	Q3	■							
法兰输出轴 (相似的 EN ISO 9409-1)	Flange output shaft (similar EN ISO 9409-1)									D
数量 x 螺纹 x 深度	Number x thread x depth	G2		8xM5x7	8xM6x10	12xM6x12	12xM8x15	12xM10x20		
带有配合销孔的法兰输出轴 (EN ISO 9409-1)	Flange output shaft with dowel hole (EN ISO 9409-1)									E
配合销孔 x 深度	Dowel hole x depth	D15	H7	5x5	6x6	6x6	8x8	10x10		
数量 x 螺纹 x 深度	Number x thread x depth	G2		7xM5x7	7xM6x10	11xM6x12	11xM8x15	11xM10x20		

⁽¹⁾ 所有的尺寸单位为mm
⁽²⁾ 减速机级数

⁽¹⁾ Dimensions in mm
⁽²⁾ Number of stages



WPLN

直角减速机 配有准双曲面齿轮，因此运行时十分安静

借助其准双曲面齿轮，WPLN 的同步运行性能得到了优化，应用设备工件加工表面质量也可达到最高水平。由于振动幅度降至最低，WPLN 运行时十分稳定且安静。这款高精度直角减速机终生润滑免维护，且可进行多面安装。

The versatile right angle gearbox with spiral teeth for a quiet drive

Thanks to its spiral teeth, our WPLN achieves the optimal synchronism for the best surface qualities. By minimizing vibrations, it runs uniformly and quietly. The precision right angle planetary gearbox features lifetime lubrication and can be mounted virtually anywhere.

- ⊕ 输入法兰可适配特殊的电机
- ⊕ 终生润滑，因此免维护
- ⊕ 反向旋转方向
- ⊕ 输出轴样式多样
- ⊕ 优化转动惯量的锁紧系统

- ⊕ Individual adaptation of the input flange to the motor
- ⊕ Lifetime lubrication for maintenance-free operation
- ⊕ Counterdirectional rotation
- ⊕ Wide range of output shaft designs
- ⊕ Clamping systems with optimized mass moment of inertia

② 运行十分安静

高品质准双曲面齿轮使得 **WPLN** 运行时的噪音极低。无需在机器上采取其他降噪措施。从而提升了整个系统的价值。

① 安装时灵活度极高

这款经过终生润滑的准双曲面齿轮行星减速机能够在运行空间极小的情况下发挥出最优效果。**WPLN** 可任意安装在任何位置，因此能创造出更多可用空间。

③ 最佳表面质量

由于配有准双曲面齿轮，**WPLN** 运行时十分稳定且振动幅度极小。这样一来，应用设备的工件加工就能实现最佳的表面和印刷图像质量。

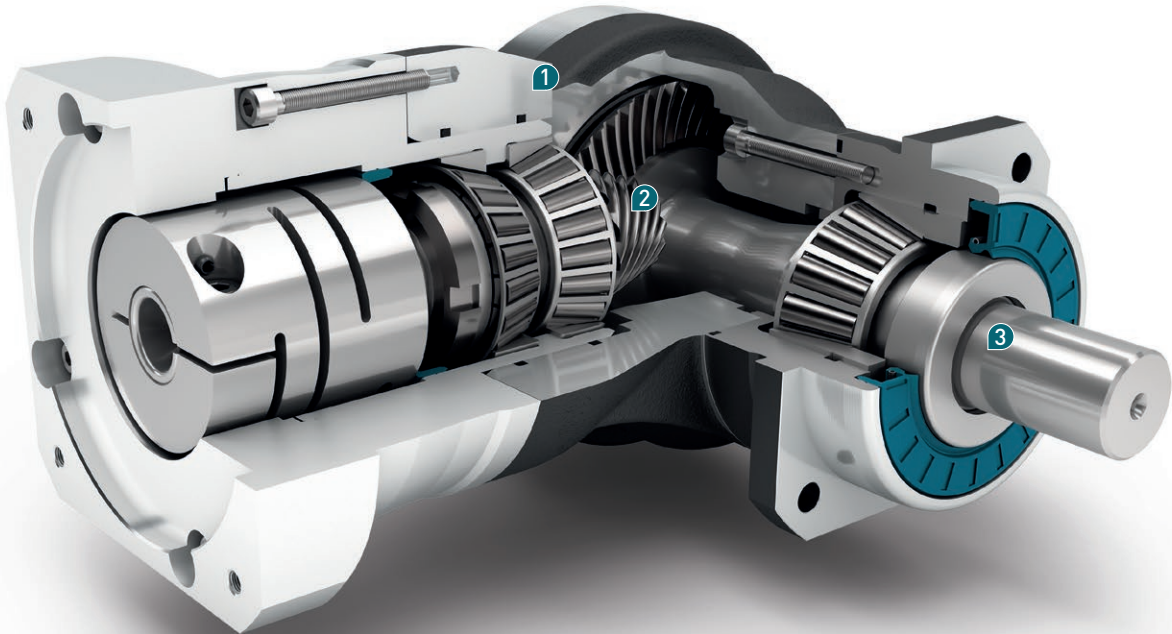

① Highest installation flexibility

Our lifetime lubricated right angle planetary gearbox extracts the most out of little space. The **WPLN** can be installed virtually anywhere, giving you greater freedom.

② Particularly quiet drive

The high-quality spiral teeth makes the **WPLN** a particularly low-noise solution. Additional sound absorption measures are not needed on your machine. The value of the whole system increases as a result.

③ Best surface quality

Thanks to its spiral teeth, the **WPLN** delivers a particularly uniform and low-vibration performance. Your machine therefore produces the highest surface quality and the best prints.

Code	减速机参数	Gearbox characteristics			WPLN070	WPLN090	WPLN115	WPLN142	z ⁽¹⁾
	使用寿命	Service life	t _L	h	20.000				
	T _{2N} × 0.88 时的使用寿命	Service life at T _{2N} × 0.88			30.000				
	满载时效率 ⁽²⁾	Efficiency at full load ⁽²⁾	η	%	95				
					94				
	最低工作温度	Min. operating temperature	T _{min}	°C	-25				
	最高工作温度	Max. operating temperature	T _{max}		90				
	防护等级	Protection class			IP 65				
S	标准润滑	Standard lubrication			润滑油 / Oil				
F	食品级润滑	Food grade lubrication			润滑油 / Oil				
	安装位置	Installation position			任意 / Any				
S	标准回程间隙	Standard backlash	j _t	arcmin	< 5				
	抗扭刚度 ⁽²⁾	Torsional stiffness ⁽²⁾	c _G	Nm / arcmin	1,8 - 2,4	4,6 - 6,2	10,1 - 13,5	25,5 - 34,0	1
					2,3 - 3,0	5,9 - 7,8	12,8 - 16,9	32,5 - 42,5	2
	减速机重量	Gearbox weight	m _G	kg	3	5	10,5	25	1
					3,9	5,3	9,2	21,5	2
S	标准的箱体表面	Standard surface			直角箱体: 铝 - 阳极氧化处理 (黑色) Right angle housing: Aluminum - anodized (black)				
	运行噪音 ⁽³⁾	Running noise ⁽³⁾	Q _g	dB(A)	66	67	68	70	
	基于减速机输入法兰的最大弯矩 ⁽⁴⁾	Max. bending moment based on the gearbox input flange ⁽⁴⁾	M _b	Nm	12	25,5	53	120	1
					12	12	25,5	53	2
	电机法兰精度	Motor flange precision			DIN 42955-R				

输出轴载荷	Output shaft loads				WPLN070	WPLN090	WPLN115	WPLN142	z ⁽¹⁾
20,000 h 的径向力 ⁽⁵⁾⁽⁶⁾	Radial force for 20,000 h ⁽⁵⁾⁽⁶⁾	F _{r20,000 h}		N	3200	5200	6000	12500	1
					3200	5500	6000	12500	2
20,000 h 的轴向力 ⁽⁵⁾⁽⁶⁾	Axial force for 20,000 h ⁽⁵⁾⁽⁶⁾	F _{a20,000 h}		N	4300	5900	7000	14500	1
					4400	6400	8000	15000	2
30,000 h 的径向力 ⁽⁵⁾⁽⁶⁾	Radial force for 30,000 h ⁽⁵⁾⁽⁶⁾	F _{r30,000 h}		N	3200	5200	6000	10900	1
					3200	4800	5400	11400	2
30,000 h 的轴向力 ⁽⁵⁾⁽⁶⁾	Axial force for 30,000 h ⁽⁵⁾⁽⁶⁾	F _{a30,000 h}		N	3700	5200	6100	12000	1
					3900	5700	7000	13200	2
静态径向力 ⁽⁶⁾⁽⁷⁾	Static radial force ⁽⁶⁾⁽⁷⁾	F _{r Stat}		N	3200	5200	6000	12500	1
					3200	5500	6000	12500	2
静态轴向力 ⁽⁶⁾⁽⁷⁾	Static axial force ⁽⁶⁾⁽⁷⁾	F _{a Stat}		N	4300	5900	7000	14500	1
					4400	6400	8000	15000	2
20,000 h 倾斜力矩 ⁽⁵⁾⁽⁷⁾	Tilting moment for 20,000 h ⁽⁵⁾⁽⁷⁾	M _{K20,000 h}		Nm	322	624	1010	2225	1
					322	660	1010	2225	2
30,000 h 倾斜力矩 ⁽⁵⁾⁽⁷⁾	Tilting moment for 30,000 h ⁽⁵⁾⁽⁷⁾	M _{K30,000 h}		Nm	322	624	1010	1940	1
					322	576	909	2029	2

转动惯量	Moment of inertia				WPLN070	WPLN090	WPLN115	WPLN142	z ⁽¹⁾
转动惯量 ⁽²⁾	Mass moment of inertia ⁽²⁾	J	kgcm ²		0,500 - 0,822	1,013 - 1,387	4,767 - 5,875	12,900 - 16,116	1
					0,498 - 0,811	0,780 - 1,114	3,493 - 4,484	11,546 - 14,397	2

(1) 减速机级数
 (2) 传动比相关的数值可在 Tec Data Finder 中检索 - www.neugart.com
 (3) 距离减速机 1 m 时; 在输入转速为 n₁=3000 min⁻¹ 且无负荷时测得; i=5
 (4) 最大发动机重量* (单位: kg) = 0.2 × M_b / 发动机长度 (单位: m)
 * 发动机重量对称分布
 * 水平和固定的安装位置
 (5) 数据以 n₂=100 min⁻¹ 的输出轴转速为准。
 (6) 以输出轴中心为准
 (7) 更改 T_{2N}, F_r, F_a 以及周期和轴承使用寿命时, 数值存在偏差 (部分较高)。利用 NCP 针对应用进行专门设计 - www.neugart.com

(1) Number of stages
 (2) The ratio-dependent values can be retrieved in Tec Data Finder - www.neugart.com
 (3) Sound pressure level from 1 m, measured on input running at n₁=3000 rpm no load; i=5
 (4) Max. motor weight* in kg = 0.2 × M_b / motor length in m
 * with symmetrically distributed motor weight
 * with horizontal and stationary mounting
 (5) These values are based on an output shaft speed of n₂=100 rpm
 (6) Based on center of output shaft
 (7) Other (sometimes higher) values following changes to T_{2N}, F_r, F_a, cycle, and service life of bearing. Application specific configuration with NCP - www.neugart.com

输出扭矩	Output torques			WPLN070	WPLN090	WPLN115	WPLN142	$i^{(1)}$	$z^{(2)}$				
额定输出扭矩 ⁽³⁾⁽⁴⁾	Nominal output torque ⁽³⁾⁽⁴⁾	T_{2N}	Nm	45	90	160	320	4	1				
				42	75	140	280	5					
				27	50	90	180	8					
				22	40	75	160	10					
				77	150	300	640	16	2				
				77	150	300	800	20					
				65	140	260	700	25					
				77	108	200	360	32					
				65	135	250	450	40					
				65	110	200	375	50					
				40	80	150	450	64					
				27	60	125	305	100					
				最大输出扭矩 ⁽⁴⁾⁽⁵⁾	Max. output torque ⁽⁴⁾⁽⁵⁾	T_{2max}	Nm	72	144	256	512	4	1
								67	120	224	448	5	
43	80	144	288					8					
35	64	120	256					10					
123	240	480	1024					16	2				
123	240	480	1280					20					
104	224	416	1120					25					
123	172	320	576					32					
104	216	400	720					40					
104	176	320	600					50					
64	128	240	720					64					
43	96	200	488					100					

(1) 传动比 ($i=n_1/n_2$)

(2) 减速机级数

(3) 利用 NCP 针对应用进行专门设计 – www.neugart.com

(4) 平键 (代码 „A”)时的数值: 针对交变载荷

(5) 允许输出轴转动30,000转; 参见第 128 页

(1) Ratios ($i=n_1/n_2$)

(2) Number of stages

(3) Application specific configuration with NCP – www.neugart.com

(4) Values for feather key (code "A"): for repeated load

(5) 30,000 rotations of the output shaft permitted; see page 129

输出扭矩	Output torques			WPLN070	WPLN090	WPLN115	WPLN142	$i^{(1)}$	$z^{(2)}$
急停扭矩 ⁽³⁾	Emergency stop torque ⁽³⁾	T_{2Stop}	Nm	100	200	400	800	4	1
				100	200	400	800	5	
				75	150	300	700	8	
				75	150	300	700	10	
				150	300	650	1600	16	2
				150	300	650	1600	20	
				150	300	650	1600	25	
				150	300	600	1200	32	
				150	300	650	1500	40	
				150	300	600	1200	50	
				80	200	380	1000	64	
				80	200	480	750	100	

输入转速	Input speeds			WPLN070	WPLN090	WPLN115	WPLN142	$i^{(1)}$	$z^{(2)}$
T_{2N} 和 S1 时的平均热输入转速 ⁽⁴⁾⁽⁵⁾	Average thermal input speed at T_{2N} and S1 ⁽⁴⁾⁽⁵⁾	n_{1N}	min^{-1}	1800 ⁽⁶⁾	1650 ⁽⁶⁾	1150 ⁽⁶⁾	950 ⁽⁶⁾	4	1
				2000 ⁽⁶⁾	1900 ⁽⁶⁾	1250 ⁽⁶⁾	1000 ⁽⁶⁾	5	
				2350 ⁽⁶⁾	2250 ⁽⁶⁾	1450 ⁽⁶⁾	1100 ⁽⁶⁾	8	
				2500 ⁽⁶⁾	2400 ⁽⁶⁾	1500 ⁽⁶⁾	1100 ⁽⁶⁾	10	
				1850 ⁽⁶⁾	1800 ⁽⁶⁾	1650 ⁽⁶⁾	1000 ⁽⁶⁾	16	2
				2000 ⁽⁶⁾	2100 ⁽⁶⁾	1950 ⁽⁶⁾	1050 ⁽⁶⁾	20	
				2150 ⁽⁶⁾	2250 ⁽⁶⁾	2150 ⁽⁶⁾	1150 ⁽⁶⁾	25	
				2300 ⁽⁶⁾	2300 ⁽⁶⁾	2200 ⁽⁶⁾	1400 ⁽⁶⁾	32	
				2400 ⁽⁶⁾	2300 ⁽⁶⁾	2250 ⁽⁶⁾	1450 ⁽⁶⁾	40	
				2500 ⁽⁶⁾	2450 ⁽⁶⁾	2400 ⁽⁶⁾	1550 ⁽⁶⁾	50	
				2600 ⁽⁶⁾	2950 ⁽⁶⁾	2850 ⁽⁶⁾	1750 ⁽⁶⁾	64	
				2700 ⁽⁶⁾	3100 ⁽⁶⁾	3050 ⁽⁶⁾	1900 ⁽⁶⁾	100	
				最高机械输入转速 ⁽⁴⁾	Max. mechanical input speed ⁽⁴⁾	n_{1Limit}	min^{-1}	16000	
16000	16000	14000	9500						2

⁽¹⁾ 传动比 ($i=n_1/n_2$)

⁽²⁾ 减速机级数

⁽³⁾ 允许 1000 次

⁽⁴⁾ 利用 NCP 针对应用设计转速 – www.neugart.com

⁽⁵⁾ 定义请参见第 128 页

⁽⁶⁾ 在 50% T_{2N} 输出和 S1 模式下的平均热传动转速

⁽¹⁾ Ratios ($i=n_1/n_2$)

⁽²⁾ Number of stages

⁽³⁾ Permitted 1000 times

⁽⁴⁾ Application-specific speed configurations with NCP – www.neugart.com

⁽⁵⁾ See page 129 for the definition

⁽⁶⁾ Average thermal input speed at 50% T_{2N} and S1

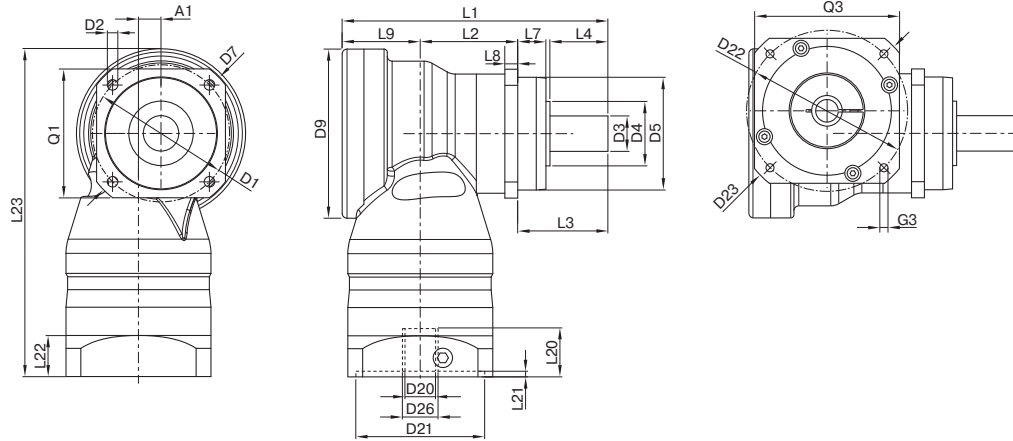

图示为带平键的 WPLN090 / 1 级 / 光滑输出轴 / 19 mm 锁紧系统 / 适配电机法兰 - 2 件式 - 圆形通用法兰 / B5 电机法兰类型
 Drawing corresponds to a WPLN090 / 1-stage / smooth output shaft / 19 mm clamping system / motor adaptation - 2-part - round universal flange / B5 flange type motor
 所有其它变量可在 www.neugart.com 下 Tec Data Finder 中检索 - All other variants can be retrieved in the Tec Data Finder at www.neugart.com

几何尺寸 ⁽¹⁾	Geometry ⁽¹⁾			WPLN070	WPLN090	WPLN115	WPLN142	z ⁽²⁾	Code	
轴向偏差	Axis offset	A1		10	14	20	26	1		
				10	10	14	20	2		
输出端安装孔节圆直径	Pitch circle diameter output	D1		68 - 75	85	120	165			
输出端安装孔直径	Mounting bore output	D2	4x	5,5	6,5	9,0	11,0			
输出轴直径	Shaft diameter output	D3	k6	16	22	32	40			
输出轴轴肩直径	Shaft collar output	D4		30	40	45	70	1		
				35	40	45	70	2		
输出端定位凸台直径	Centering diameter output	D5	g7	60	70	90	130			
输出法兰对角线尺寸	Diagonal dimension output	D7		92	100	140	185			
最大直径	Max. diameter	D9		86	105	120	170	1		
				86	86	105	120	2		
输出端法兰外方	Flange cross section output	Q1	■	70	80	110	142			
总长	Total length	L1		137,5	165	218	273	1		
				185	207	248,5	342,5	2		
箱体长度	Housing length	L2		46,5	60,5	73,5	76	1		
				94	108	112	176	2		
输出轴轴长	Shaft length output	L3		48	56	88	110			
输出端定位凸台深度	Centering depth output	L7		18	17,5	28	28			
输出端法兰厚度	Flange thickness output	L8		7	8	10	12			
偏差距离	Offset length	L9		43	48,5	56,5	87	1		
				43	43	48,5	56,5	2		
最小总高度	Min. overall height	L23		179,0	203,5	247,5	318,0	1		
				179,0	182,5	210,0	258,5	2		
输入端锁紧系统直径	Clamping system diameter input	D26		更多信息见第 117 页 More information on page 117					具体尺寸视电机/减速机法兰而定。 可以在 www.neugart.com 下 Tec Data Finder. 中针对每个电机适配电机特有的输入法兰几何尺寸 The dimensions vary with the motor/gearbox flange. The input flange geometries can be retrieved for each specific motor in Tec Data Finder at www.neugart.com	
电机轴直径 j6/k6	Motor shaft diameter j6/k6	D20								
最大允许的电机轴长	Max. permis. motor shaft length	L20								
最小允许的电机轴长	Min. permis. motor shaft length									
输入端定位凹槽直径	Centering diameter input	D21								
输入端定位凹槽深度	Centering depth input	L21								
输入端安装孔节圆直径	Pitch circle diameter input	D22								
输入法兰长度	Motor flange length	L22								
输入法兰对角线尺寸	Diagonal dimension input	D23								
安装螺纹 x 深度	Mounting thread x depth	G3	4x							
输入端法兰外方	Flange cross section input	Q3	■							
附带平键的输出轴 (DIN 6885-1)	Output shaft with feather key (DIN 6885-1)			A 5x5x25	A 6x6x28	A 10x8x50	A 12x8x65			A
平键宽度 (DIN 6885-1)	Feather key width (DIN 6885-1)	B1		5	6	10	12			
含平键在内的轴高 (DIN 6885-1)	Shaft height including feather key (DIN 6885-1)	H1		18	24,5	35	43			
到轴肩的距离	Shaft length from shoulder	L4		28	36	58	80			
平键长度	Feather key length	L5		25	28	50	65			
到轴端的距离	Distance from shaft end	L6		2	4	4	8			
中心孔 (DIN 332, DR 形)	Center hole (DIN 332, type DR)	Z		M5x12,5	M8x19	M12x28	M16x36			
光滑输出轴	Smooth output shaft								B	
到轴肩的距离	Shaft length from shoulder	L4		28	36	58	80			

⁽¹⁾ 所有的尺寸单位为mm
⁽²⁾ 减速机级数

⁽¹⁾ Dimensions in mm
⁽²⁾ Number of stages



WGN

空心轴式输出的准双曲面齿轮减速机——噪音低，以涨紧力传递的方式进行安装

WGN 是一款运行极安静的空心轴输出准双曲面齿轮减速机。同时，准双曲面齿轮可提高应用设备的工件表面的质量。使用一个涨紧套，便可直接将其连接至应用上——简单、安全，提供了新的结构设计型式。

The spiral-toothed right angle gearbox with hollow shaft – low noise levels and force-fit installation

Our WGN is a hollow-shaft right angle gearbox that operates with particularly low noise levels. At the same time, the spiral teeth increase the quality of your workpiece surfaces. It can be connected directly to the application via a shrink disc, a simple and reliable solution that offers you new design possibilities.

- + 输入法兰可适配特殊的电机
- + 终生润滑，因此免维护
- + 反向旋转方向
- + 输出轴样式多样
- + 优化转动惯量的锁紧系统
- + 可通过空心轴敷设线缆

- + Individual adaptation of the input flange to the motor
- + Lifetime lubrication for maintenance-free operation
- + Counterdirectional rotation
- + Wide range of output shaft designs
- + Clamping systems with optimized mass moment of inertia
- + Line routing possible through hollow shaft

② 采用智能型齿轮，提升质量

借助其准双曲面齿轮，**WGN** 的同步运行性能也得到了优化。这样一来，使使用设备的工件表面的质量以及印刷图像的质量都能达到最高水准。

① 运行十分安静

由于采用了我们研发的准双曲面齿轮，**WGN** 运行时十分安静且振动幅度很小。机器上无需任何其他隔音措施。

③ 便捷、安全、力传递

您可使用一个涨紧套将准双曲面减速机 **WGN** 的空心轴连接至机器轴上。这一过程安全、简便，还能节省空间。

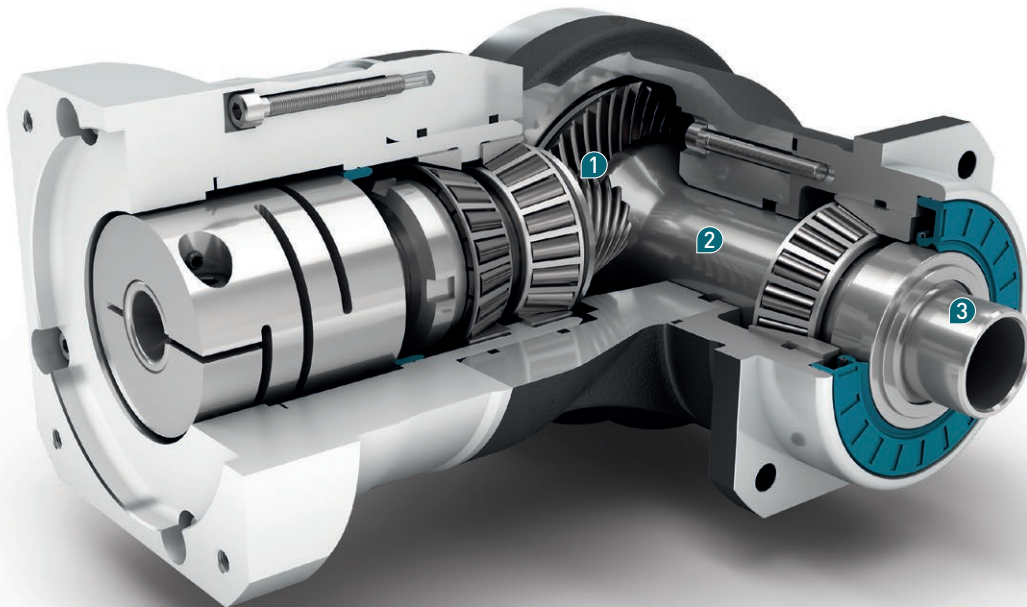

① Particularly quiet drive

Thanks to the Neugart-developed spiral teeth, the **WGN** delivers particularly quiet and low-vibration performance. The machine does not need any additional noise absorption measures.

③ Easy, reliable, force-fit

The hollow shaft in the **WGN** right angle gearbox can be force-fit to your machine shaft via shrink disc. This is reliable, simple, and saves space.

② Best surface quality

Thanks to its spiral teeth, the **WGN** achieves the optimal synchronism. You therefore benefit from the highest quality for your workpiece surfaces and prints.

Code	减速机参数	Gearbox characteristics			WGN070	WGN090	WGN115	WGN142	z ⁽¹⁾
	使用寿命	Service life	t _L	h	20.000				1
	T _{2N} × 0.88 时的使用寿命	Service life at T _{2N} × 0.88			30.000				
	满载时效率 ⁽²⁾	Efficiency at full load ⁽²⁾	η	%	95				
	最低工作温度	Min. operating temperature	T _{min}	°C	-25				
	最高工作温度	Max. operating temperature	T _{max}		90				
	防护等级	Protection class	IP 65						
S	标准润滑	Standard lubrication	润滑油 / Oil						
F	食品级润滑	Food grade lubrication	润滑油 / Oil						
	安装位置	Installation position	任意 / Any						
S	标准回程间隙	Standard backlash	j _i	arcmin	< 5				
	抗扭刚度 ⁽²⁾	Torsional stiffness ⁽²⁾	c _g	Nm / arcmin	1,6 - 2,2	4,2 - 5,7	9,2 - 12,4	23,5 - 31,5	
	减速机重量	Gearbox weight	m _G	kg	3	5	9,2	25	
S	标准的箱体表面	Standard surface	直角箱体: 铝 - 阳极氧化处理 (黑色) Right angle housing: Aluminum - anodized (black)						
	运行噪音 ⁽³⁾	Running noise ⁽³⁾	Q _g	dB(A)	66	67	68	70	
	基于减速机输入法兰的最大弯矩 ⁽⁴⁾	Max. bending moment based on the gearbox input flange ⁽⁴⁾	M _b	Nm	12	25,5	53	120	
	电机法兰精度	Motor flange precision	DIN 42955-R						

输出轴载荷	Output shaft loads				WGN070	WGN090	WGN115	WGN142	z ⁽¹⁾		
20,000 h 的径向力 ⁽⁵⁾⁽⁶⁾	Radial force for 20,000 h ⁽⁵⁾⁽⁶⁾	F _{r20.000h}	N		2700	4000	6500	10000	1		
20,000 h 的轴向力 ⁽⁵⁾⁽⁶⁾	Axial force for 20,000 h ⁽⁵⁾⁽⁶⁾	F _{a20.000h}			4300	5900	7000	14500			
30,000 h 的径向力 ⁽⁵⁾⁽⁶⁾	Radial force for 30,000 h ⁽⁵⁾⁽⁶⁾	F _{r30.000h}			2700	4000	6500	10000			
30,000 h 的轴向力 ⁽⁵⁾⁽⁶⁾	Axial force for 30,000 h ⁽⁵⁾⁽⁶⁾	F _{a30.000h}			3700	5200	6100	12000			
静态径向力 ⁽⁶⁾⁽⁷⁾	Static radial force ⁽⁶⁾⁽⁷⁾	F _{r Stat}			2700	4000	6500	10000			
静态轴向力 ⁽⁶⁾⁽⁷⁾	Static axial force ⁽⁶⁾⁽⁷⁾	F _{a Stat}			4300	5900	7000	14500			
20,000 h 倾斜力矩 ⁽⁵⁾⁽⁷⁾	Tilting moment for 20,000 h ⁽⁵⁾⁽⁷⁾	M _{K20.000h}			Nm		252	442		970	1505
30,000 h 倾斜力矩 ⁽⁵⁾⁽⁷⁾	Tilting moment for 30,000 h ⁽⁵⁾⁽⁷⁾	M _{K30.000h}					252	442		970	1505

转动惯量	Moment of inertia				WGN070	WGN090	WGN115	WGN142	z ⁽¹⁾
转动惯量 ⁽²⁾	Mass moment of inertia ⁽²⁾	J	kgcm ²		0,502 - 0,834	0,908 - 1,417	4,805 - 6,111	12,885 - 16,204	1

(1) 减速机级数
 (2) 传动比相关的数值可在 Tec Data Finder 中检索 - www.neugart.com
 (3) 距离减速机 1 m 时; 在输入转速为 n₁=3000 min⁻¹ 且无负荷时测得; i=5
 (4) 最大发动机重量* (单位: kg) = 0.2 × M_b / 发动机长度 (单位: m)
 * 发动机重量对称分布
 * 水平和固定的安装位置
 (5) 数据以 n₂=100 min⁻¹ 的输出轴转速为准。
 (6) 以输出轴中心为准
 (7) 更改 T_{2N}, F_r, F_a 以及周期和轴承使用寿命时, 数值存在偏差 (部分较高)。利用 NCP 针对应用进行专门设计 - www.neugart.com

(1) Number of stages
 (2) The ratio-dependent values can be retrieved in Tec Data Finder - www.neugart.com
 (3) Sound pressure level from 1 m, measured on input running at n₁=3000 rpm no load; i=5
 (4) Max. motor weight* in kg = 0.2 × M_b / motor length in m
 * with symmetrically distributed motor weight
 * with horizontal and stationary mounting
 (5) These values are based on an output shaft speed of n₂=100 rpm
 (6) Based on center of output shaft
 (7) Other (sometimes higher) values following changes to T_{2N}, F_r, F_a, cycle, and service life of bearing. Application specific configuration with NCP - www.neugart.com

输出扭矩	Output torques			WGN070	WGN090	WGN115	WGN142	$i^{(1)}$	$z^{(2)}$
额定输出扭矩 ⁽³⁾	Nominal output torque ⁽³⁾	T_{2N}	Nm	45	70	140	320	4	1
				42	70	140	280	5	
				27	50	90	180	8	
				22	40	75	160	10	
最大输出扭矩 ⁽⁴⁾	Max. output torque ⁽⁴⁾	T_{2max}	Nm	72	112	224	512	4	
				67	112	224	448	5	
				43	80	144	288	8	
				35	64	120	256	10	
急停扭矩 ⁽⁵⁾	Emergency stop torque ⁽⁵⁾	T_{2stop}	Nm	100	200	400	800	4	
				100	200	400	800	5	
				75	150	300	700	8	
				75	150	300	700	10	

输入转速	Input speeds			WGN070	WGN090	WGN115	WGN142	$i^{(1)}$	$z^{(2)}$
T_{2N} 和 S1 时的平均热输入转速 ⁽⁶⁾⁽⁷⁾	Average thermal input speed at T_{2N} and S1 ⁽⁶⁾⁽⁷⁾	n_{1N}	min^{-1}	1750 ⁽⁸⁾	1700 ⁽⁸⁾	1150 ⁽⁸⁾	950 ⁽⁸⁾	4	1
				1900 ⁽⁸⁾	1850 ⁽⁸⁾	1200 ⁽⁸⁾	950 ⁽⁸⁾	5	
				2300 ⁽⁸⁾	2200 ⁽⁸⁾	1400 ⁽⁸⁾	1050 ⁽⁸⁾	8	
				2400 ⁽⁸⁾	2350 ⁽⁸⁾	1500 ⁽⁸⁾	1050 ⁽⁸⁾	10	
最高机械输入转速 ⁽⁶⁾	Max. mechanical input speed ⁽⁶⁾	n_{1Limit}	min^{-1}	16000	14000	9500	8000		

(1) 传动比 ($i=n_1/n_2$)

(2) 减速机级数

(3) 利用 NCP 针对应用进行专门设计 – www.neugart.com

(4) 允许输出轴转动30,000转; 参见第 128 页

(5) 允许 1000 次

(6) 利用 NCP 针对应用进行专门设计 – www.neugart.com

(7) 定义请参见第 128 页

(8) 在 50% T_{2N} 输出和 S1 模式下的平均热传动转速(1) Ratios ($i=n_1/n_2$)

(2) Number of stages

(3) Application specific configuration with NCP – www.neugart.com

(4) 30,000 rotations of the output shaft permitted; see page 129

(5) Permitted 1000 times

(6) Application-specific speed configurations with NCP – www.neugart.com

(7) See page 129 for the definition

(8) Average thermal input speed at 50% T_{2N} and S1

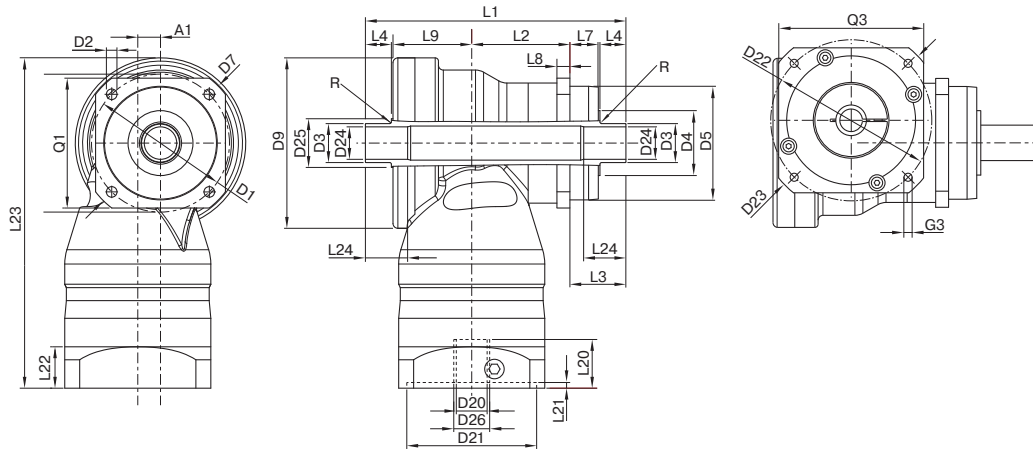

图示为带平键的 WGN090 / 1 级 / 双侧空心输出轴 / 19 mm 锁紧系统 / 适配电机法兰 - 2 件式 - 圆形通用法兰 / B5 电机法兰类型
 Drawing corresponds to a WGN090 / 1-stage / hollow output shaft on both sides / 19 mm clamping system / motor adaptation - 2-part - round universal flange / B5 flange type motor
 所有其它变量可在 www.neugart.com 下 Tec Data Finder 中检索 - All other variants can be retrieved in the Tec Data Finder at www.neugart.com

几何尺寸 ⁽¹⁾	Geometry ⁽¹⁾			WGN070	WGN090	WGN115	WGN142	z ⁽²⁾	Code
轴向偏差	Axis offset	A1		10	14	20	26	1	
输出端安装孔节圆直径	Pitch circle diameter output	D1		68 - 75	85	120	165		
输出端安装孔直径	Mounting bore output	D2	4x	5,5	6,5	9,0	11,0		
输出轴直径	Shaft diameter output	D3	h8	18	24	36	50		
输出轴轴肩直径	Shaft collar output	D4		24	34	45	70		
输出端定位凸台直径	Centering diameter output	D5	g7	60	70	90	130		
输出法兰对角线尺寸	Diagonal dimension output	D7		92	100	140	185		
最大直径	Max. diameter	D9		86	105	120	170		
输出端法兰外方	Flange cross section output	Q1	■	70	80	110	142		
箱体长度	Housing length	L2		46,5	60,5	73,5	76		
输出轴轴长	Shaft length output	L3		33	34,5	48	54		
输出端定位凸台深度	Centering depth output	L7		18	17,5	27	28		
输出端法兰厚度	Flange thickness output	L8		7	8	10	12		
偏差距离	Offset length	L9		43	48,5	56,5	87		
最小总高度	Min. overall height	L23		179	204	248	318		
最大半径	Max. radius	R		1,5	1,5	1,5	1,5		
输入端锁紧系统直径	Clamping system diameter input	D26		更多信息见第 117 页 More information on page 117					
电机轴直径 j6/k6	Motor shaft diameter j6/k6	D20		具体尺寸视电机/减速机法兰而定。 可以在 www.neugart.com 下 Tec Data Finder. 中针对每个电机适配电机特有的输入法兰几何尺寸 The dimensions vary with the motor/gearbox flange. The input flange geometries can be retrieved for each specific motor in Tec Data Finder at www.neugart.com					
最大允许的电机轴长	Max. permis. motor shaft length	L20							
最小允许的电机轴长	Min. permis. motor shaft length								
输入端定位凹槽直径	Centering diameter input	D21							
输入端定位凹槽深度	Centering depth input	L21							
输入端安装孔节圆直径	Pitch circle diameter input	D22							
输入法兰长度	Motor flange length	L22							
输入法兰对角线尺寸	Diagonal dimension input	D23							
安装螺纹 x 深度	Mounting thread x depth	G3	4x						
输入端法兰外方	Flange cross section input	Q3	■						
单侧空心输出轴	Hollow output shaft on one side							F	
空心轴直径	Hollow shaft diameter	D24	H6	15	20	30	40		
总长	Total length	L1		122,5	143,5	179	217		
到轴肩的距离	Shaft length from shoulder	L4		14	16	20	25		
最小配合长度	Min. fit length	L24		20	25	30	35	G	
双侧空心输出轴	Hollow output shaft on both sides								
空心轴直径	Hollow shaft diameter	D24	H6	15	20	30	40		
轴肩	Shaft collar	D25		25	30	42	58		
总长	Total length	L1		137,5	160,5	200	243		
到轴肩的距离	Shaft length from shoulder	L4		14	16	20	25		
最小配合长度	Min. fit length	L24		20	25	30	35		

⁽¹⁾ 所有的尺寸单位为mm
⁽²⁾ 减速机级数

⁽¹⁾ Dimensions in mm
⁽²⁾ Number of stages

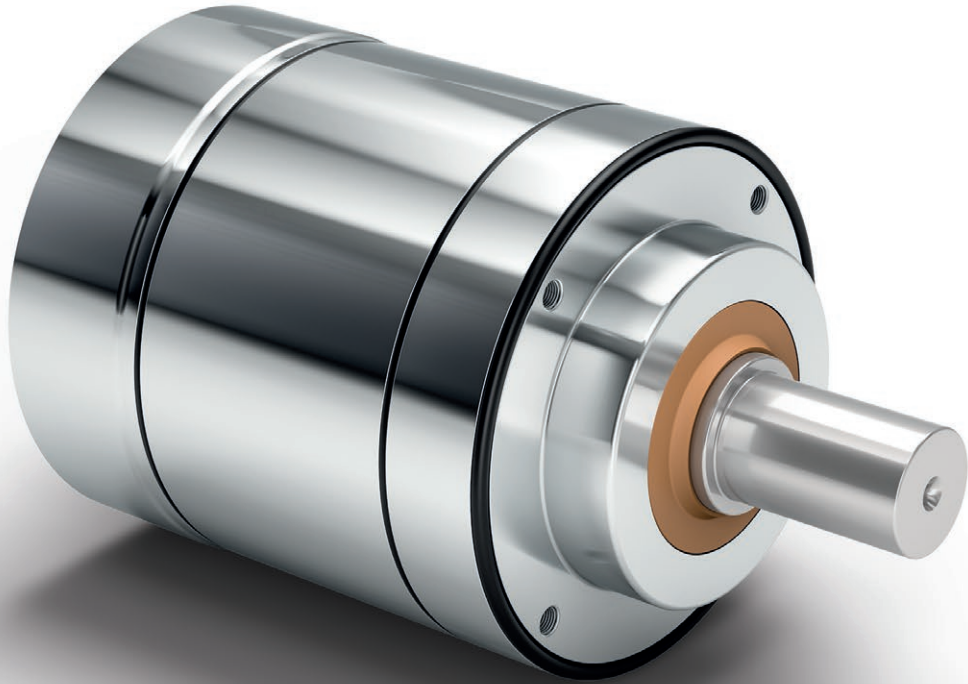

HLAE

独一无二的行星轮减速机 采用经过认证的卫生设计 – 安全 清洁流程的理想之选

HLAE 具有独一无二的优势：它是世界首款采用经过认证的卫生设计的行星减速机——减速机外表无螺栓，因此灵活多变；性能出众；便于清洁。专为敏感领域，如医药、化妆品和食品行业应用而研发。

- ⊕ 可安装在任意位置
- ⊕ 输入法兰可适配特殊的电机
- ⊕ 终生润滑，因此免维护
- ⊕ 旋转方向同向
- ⊕ 输出轴样式多样
- ⊕ 精确啮合
- ⊕ 可选择耐化学品和耐热性能更强的 FFKM 密封件

The unique planetary gearbox with certified hygienic design – ideal for reliable cleaning processes

Our **HLAE** is unique: It is the world's first planetary gearbox with certified hygienic design – flexible without a radial screw, powerful, and yet ideal for fast and easy cleaning. It has been developed specifically for challenging applications such as in the pharmaceutical, cosmetics, and food industries.

- ⊕ For any mounting position
- ⊕ Individual adaptation of the input flange to the motor
- ⊕ Lifetime lubrication for maintenance-free operation
- ⊕ Equidirectional rotation
- ⊕ Wide range of output shaft designs
- ⊕ Precise gearing
- ⊕ Optional FFKM seals for greater chemical and heat resistance

② 经过认证的安全性

HLAE 在全球市场上都是独一无二的这是第一款经过 3-A RPSCQC 认证的行星减速机。因此是食品、医药或化妆品行业的理想之选。

③ 清洁便捷安全

电解抛光的表面是 **HLAE** 行星减速机的主要特色。凭借这一特点，它超出了常规卫生标准的要求，也实现了迅速的无菌清洁（甚至在高压下）。

① 安装时十分灵活

HLAE 配有可自由安放的密封套件，因此能够实现最大程度的卫生保护，并适用于不同的壁厚。在连接至机器时，其灵活性也是无与伦比的。

④ 独特的圆形设计

HLAE 外表无连接螺丝。将卫生设计式行星减速机连接至电机时，其灵活性也是无与伦比的。这样就能确保完整的无死角表面，没有任何界限。

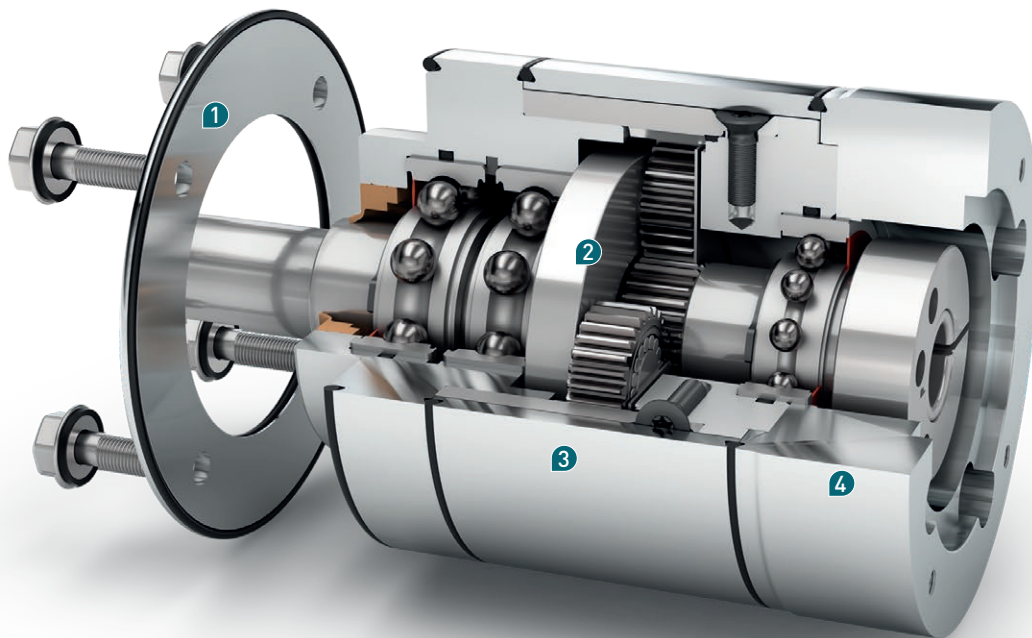

① For particularly flexible installations

Designed for free positioning, the **HLAE** sealing kit provides the highest level of hygienic protection and is therefore the ideal universal solution for a wide range of machine wall thicknesses. It can therefore be connected to the machine with the maximum flexibility.

④ Unique and all-inclusive

The **HLAE** does not need a radial screw. The hygienic design planetary gearbox can consequently be connected to your motor with maximum flexibility. The result is a surface completely and uncompromisingly free of dead space.

② Certified protection

Our **HLAE** is unique in the world. It is the first planetary gearbox to be awarded a 3-A RPSCQC certificate. It is thus ideal for the industrial production of food, pharmaceuticals, and cosmetics.

③ Fast and easy to clean

The electropolished surface is one of the main features of our **HLAE** planetary gearbox. It exceeds the usual hygiene standards and allows for fast aseptic cleaning, even under high pressure.

Code	减速机参数	Gearbox characteristics			HLAE070	HLAE090	HLAE110	z ⁽¹⁾
	使用寿命	Service life	t _L	h	30.000			
	满载时效率 ⁽²⁾	Efficiency at full load ⁽²⁾	η	%	98			1
					97			2
	最低工作温度	Min. operating temperature	T _{min}	°C	-25			
	最高工作温度	Max. operating temperature	T _{max}		90			
防护等级	Protection class		IP69K					
F	食品级润滑	Food grade lubrication		润滑脂 / Grease				
	安装位置	Installation position		任意 / Any				
S	标准回程间隙	Standard backlash	j _t	arcmin	< 10	< 7	< 7	1
					< 12	< 9	< 9	2
	抗扭刚度 ⁽²⁾	Torsional stiffness ⁽²⁾	c _G	Nm / arcmin	1,5 - 2,1	3,9 - 5,2	9,7 - 13,1	1
					1,5 - 2,1	4,0 - 5,2	9,9 - 13,1	2
	减速机重量	Gearbox weight	m _G	kg	2,1	3	8,7	1
S	标准的箱体表面	Standard surface				箱体: 不锈钢 1.4404 – 电解抛光 (R _a < 0,8 μm) Housing: Stainless steel 1.4404 – electropolished (R _a < 0,8 μm)		
			运行噪音 ⁽³⁾	Running noise ⁽³⁾	Q _G	dB(A)	58	60
	基于减速机输入法兰的最大弯矩 ⁽⁴⁾	Max. bending moment based on the gearbox input flange ⁽⁴⁾	M _b	Nm	8	16	40	
	电机法兰精度	Motor flange precision				DIN 42922-N		

输出轴载荷	Output shaft loads			HLAE070	HLAE090	HLAE110	z ⁽¹⁾
20,000 h 的径向力 ⁽⁵⁾⁽⁶⁾	Radial force for 20,000 h ⁽⁵⁾⁽⁶⁾	F _{r 20.000 h}	N	450	900	1450	
20,000 h 的轴向力 ⁽⁵⁾⁽⁶⁾	Axial force for 20,000 h ⁽⁵⁾⁽⁶⁾	F _{a 20.000 h}		550	1500	2500	
30,000 h 的径向力 ⁽⁵⁾⁽⁶⁾	Radial force for 30,000 h ⁽⁵⁾⁽⁶⁾	F _{r 30.000 h}		400	600	1250	
30,000 h 的轴向力 ⁽⁵⁾⁽⁶⁾	Axial force for 30,000 h ⁽⁵⁾⁽⁶⁾	F _{a 30.000 h}		500	1000	2000	
静态径向力 ⁽⁶⁾⁽⁷⁾	Static radial force ⁽⁶⁾⁽⁷⁾	F _{r Stat}		1000	1250	5000	
静态轴向力 ⁽⁶⁾⁽⁷⁾	Static axial force ⁽⁶⁾⁽⁷⁾	F _{a Stat}		1200	1600	3800	
20,000 h 倾斜力矩 ⁽⁵⁾⁽⁷⁾	Tilting moment for 20,000 h ⁽⁵⁾⁽⁷⁾	M _{K 20.000 h}	Nm	22	49	109	
30,000 h 倾斜力矩 ⁽⁵⁾⁽⁷⁾	Tilting moment for 30,000 h ⁽⁵⁾⁽⁷⁾	M _{K 30.000 h}		19	33	94	

转动惯量	Moment of inertia			HLAE070	HLAE090	HLAE110	z ⁽¹⁾
转动惯量 ⁽²⁾	Mass moment of inertia ⁽²⁾	J	kgcm ²	0,064 - 0,135	0,390 - 0,770	1,300 - 2,630	1
				0,064 - 0,131	0,390 - 0,740	1,300 - 2,620	2

(1) 减速机级数

(2) 传动比相关的数值可在 Tec Data Finder 中检索 – www.neugart.com

(3) 距离减速机 1 m 时; 在输入转速为 n₁=3000 min⁻¹ 且无负荷时测得; i=5

(4) 最大发动机重量* (单位: kg) = 0.2 × M_b / 发动机长度 (单位: m)

* 发动机重量对称分布

* 水平和固定的安装位置

(5) 数据以 n₂=100 min⁻¹ 的输出轴转速为准。

(6) 以输出轴中心为准

(7) 更改 T_{2N}, F_r, F_a 以及周期和轴承使用寿命时, 数值存在偏差 (部分较高)。利用 NCP 针对应用进行专门设计 – www.neugart.com

(1) Number of stages

(2) The ratio-dependent values can be retrieved in Tec Data Finder – www.neugart.com

(3) Sound pressure level from 1 m, measured on input running at n₁=3000 rpm no load; i=5

(4) Max. motor weight* in kg = 0.2 × M_b / motor length in m

* with symmetrically distributed motor weight

* with horizontal and stationary mounting

(5) These values are based on an output shaft speed of n₂=100 rpm

(6) Based on center of output shaft

(7) Other (sometimes higher) values following changes to T_{2N}, F_r, F_a, cycle, and service life of bearing. Application specific configuration with NCP – www.neugart.com

输出扭矩	Output torques			HLAE070	HLAE090	HLAE110	$i^{(1)}$	$z^{(2)}$
额定输出扭矩 ⁽³⁾⁽⁴⁾	Nominal output torque ⁽³⁾⁽⁴⁾	T_{2N}	Nm	28	85	115	3	1
				33	87	155	4	
				30	82	171	5	
				25	65	135	7	
				18	50	120	8	
				15	38	95	10	
				33	87	157	9	2
				33	80	171	12	
				33	82	171	15	
				33	87	171	16	
				33	87	171	20	
				30	82	171	25	
				33	87	171	32	
				30	82	171	40	
				18	50	120	64	
				15	38	95	100	
最大输出扭矩 ⁽⁴⁾⁽⁵⁾	Max. output torque ⁽⁴⁾⁽⁵⁾	T_{2max}	Nm	45	136	184	3	1
				53	140	248	4	
				48	131	274	5	
				40	104	216	7	
				29	80	192	8	
				24	61	152	10	
				53	140	251	9	2
				53	140	274	12	
				53	131	274	15	
				53	140	274	16	
				53	140	274	20	
				48	131	274	25	
				53	140	274	32	
				48	131	274	40	
				29	80	192	64	
				24	61	152	100	

(1) 传动比 ($i=n_1/n_2$)

(2) 减速机级数

(3) 利用 NCP 针对应用进行专门设计 – www.neugart.com

(4) 平键 (代码 „A”)时的数值: 针对交变载荷

(5) 允许输出轴转动30,000转; 参见第 128 页

(1) Ratios ($i=n_1/n_2$)

(2) Number of stages

(3) Application specific configuration with NCP – www.neugart.com

(4) Values for feather key (code "A"): for repeated load

(5) 30,000 rotations of the output shaft permitted; see page 129

输出扭矩	Output torques			HLAE070	HLAE090	HLAE110	i ⁽¹⁾	z ⁽²⁾
急停扭矩 ⁽³⁾	Emergency stop torque ⁽³⁾	T _{2Stop}	Nm	56	170	230	3	1
				66	174	310	4	
				60	164	342	5	
				50	130	270	7	
				36	100	240	8	
				30	76	190	10	
				66	174	314	9	2
				66	174	342	12	
				66	164	342	15	
				66	174	342	16	
				66	174	342	20	
				60	164	342	25	
				66	174	342	32	
				60	164	342	40	
				36	100	240	64	
				30	76	190	100	

输入转速	Input speeds			HLAE070	HLAE090	HLAE110	i ⁽¹⁾	z ⁽²⁾					
T _{2N} 和 S1 时的平均热输入转速 ⁽⁴⁾⁽⁵⁾	Average thermal input speed at T _{2N} and S1 ⁽⁴⁾⁽⁵⁾	n _{1N}	min ⁻¹	3000	2500	2000	3	1					
				3000	2500	2000	4						
				3000	2500	2000	5						
				3000	2500	2000	7						
				3000	2500	2000	8						
				3000	2500	2000	10						
				3000	3000	2500	9	2					
				3000	3000	2500	12						
				3000	3000	2500	15						
				3000	3000	2500	16						
				3000	3000	2500	20						
				3000	3000	2500	25						
				3000	3000	2500	32						
				3000	3000	2500	40						
				3000	3000	2500	64						
				3000	3000	2500	100						
				最高机械输入转速 ⁽⁴⁾	Max. mechanical input speed ⁽⁴⁾	n _{1Limit}	min ⁻¹		13000	7000	6500		

⁽¹⁾ 传动比 (i=n₁/n₂)

⁽²⁾ 减速机级数

⁽³⁾ 允许 1000 次

⁽⁴⁾ 利用 NCP 针对应用设计转速 - www.neugart.com

⁽⁵⁾ 定义请参见第 128 页

⁽⁶⁾ 在 50% T_{2N} 输出和 S1 模式下的平均热传动转速

⁽¹⁾ Ratios (i=n₁/n₂)

⁽²⁾ Number of stages

⁽³⁾ Permitted 1000 times

⁽⁴⁾ Application-specific speed configurations with NCP - www.neugart.com

⁽⁵⁾ See page 129 for the definition

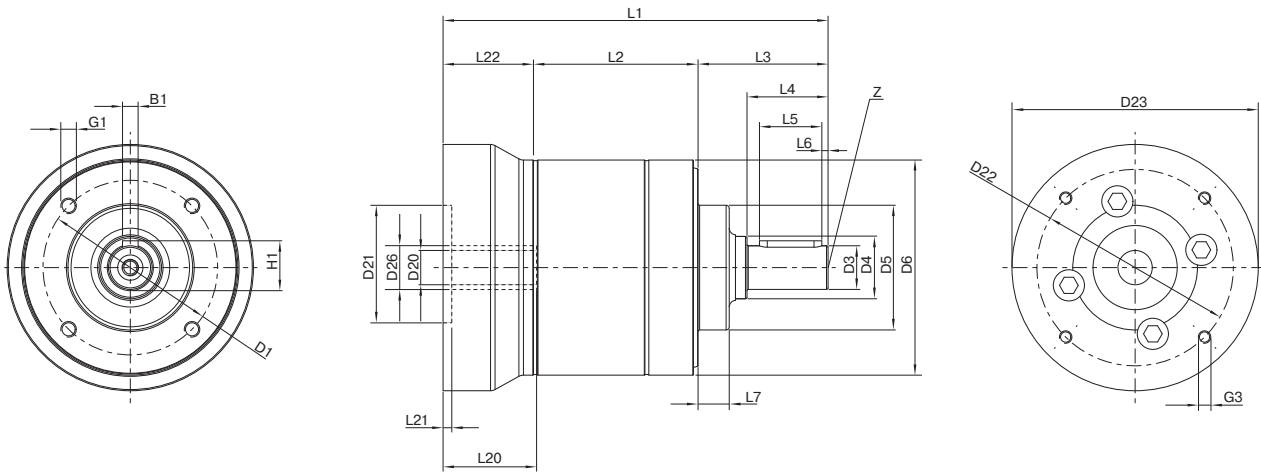

⁽⁶⁾ Average thermal input speed at 50% T_{2N} and S1



图示为带平键的 HLAE070 / 1 级 / 附带平键的输出轴 / 11 mm 锁紧系统 / 适配电机法兰 - 单一法兰 / B5 电机法兰类型

Drawing corresponds to a HLAE070 / 1-stage / output shaft with feather key / 11 mm clamping system / motor adaptation - one part / B5 flange type motor

所有其它变量可在 www.neugart.com 下 Tec Data Finder 中检索 - All other variants can be retrieved in the Tec Data Finder at www.neugart.com

几何尺寸 ⁽¹⁾	Geometry ⁽¹⁾			HLAE070	HLAE090	HLAE110	z ⁽²⁾	Code
输出端安装孔节圆直径	Pitch circle diameter output	D1		56	75	90		
输出轴直径	Shaft diameter output	D3	h7	14	20	25		
输出轴轴肩直径	Shaft collar output	D4		20	25	35		
输出端定位凸台直径	Centering diameter output	D5	h7	40	58	65		
箱体直径	Housing diameter	D6		69	88	109		
安装螺纹 x 深度	Mounting thread x depth	G1	4x	M5x11	M6x12	M8x20		
最小总长	Min. total length	L1		123,5	146	191	1	
				135,5	166	219	2	
箱体长度	Housing length	L2		52,8	68,0	89,0	1	
				64,8	88,0	117,0	2	
输出轴轴长	Shaft length output	L3		41,7	50	66,5		
输出端定位凸台深度	Centering depth output	L7		10	13	14		
输入端锁紧系统直径	Clamping system diameter input	D26		更多信息见第 117 页 More information on page 117				
电机轴直径 j6/k6	Motor shaft diameter j6/k6	D20		具体尺寸视电机/减速机法兰而定。 可以在 www.neugart.com 下 Tec Data Finder. 中针对每个电机适配电机特有的输入法兰几何尺寸 The dimensions vary with the motor/gearbox flange. The input flange geometries can be retrieved for each specific motor in Tec Data Finder at www.neugart.com				
最大允许的电机轴长	Max. permis. motor shaft length	L20						
最小允许的电机轴长	Min. permis. motor shaft length							
输入端定位凹槽直径	Centering diameter input	D21						
输入端定位凹槽深度	Centering depth input	L21						
输入端安装孔节圆直径	Pitch circle diameter input	D22						
输入法兰长度	Motor flange length	L22						
输入法兰对角线尺寸	Diagonal dimension input	D23						
安装螺纹 x 深度	Mounting thread x depth	G3	4x					
附带平键的输出轴 (DIN 6885-1)	Output shaft with feather key (DIN 6885-1)						A 5x5x20	A 6x6x25
平键宽度 (DIN 6885-1)	Feather key width (DIN 6885-1)	B1		5	6	8		A
含平键在内的轴高 (DIN 6885-1)	Shaft height including feather key (DIN 6885-1)	H1		16	22,5	28		
到轴肩的距离	Shaft length from shoulder	L4		26	32	45		
平键长度	Feather key length	L5		20	25	35		
到轴端的距离	Distance from shaft end	L6		2	2,5	5		
中心孔 (DIN 332, DR 形)	Center hole (DIN 332, type DR)	Z		M5x12,5	M6x16	M10x22		
光滑输出轴	Smooth output shaft							B
到轴肩的距离	Shaft length from shoulder	L4		26	32	45		

⁽¹⁾ 所有的尺寸单位为mm

⁽²⁾ 减速机级数

⁽¹⁾ Dimensions in mm

⁽²⁾ Number of stages

参见下一页 See next page

分隔符 Separator

结构尺寸 Frame size	PLE	PLQE	PLPE	PLHE	PLFE	WPLE	WPLOE	WPLPE	WPLFE	PSBN	PSN	PLN	PSFN	PLFN	WPLN	WGN	HLAE	Z ³⁾	输入端锁紧系统直径 Clamping system diameter input
	40	50					40	50											1/2/3
40	50					40	50			70	70		64					1/2/3	9 mm 锁紧系统直径 Clamping system diameter B
40	60	50	60	64	60	60	70	64	70	70	70		64				70	1	11 mm 锁紧系统直径 Clamping system diameter C
60	60	70	60	64	60	60	70	64	70	70	70		64	64	70	70	70	1	14 mm 锁紧系统直径 Clamping system diameter D
60	60	70	60	64	60	60	70	64	70	70	70		64	64	70	70	70	2/3	19 mm 锁紧系统直径 Clamping system diameter E
80	80	90	80	90	80	80	90	90	90	90	90		64	64	70	70	90	1	24 mm 锁紧系统直径 Clamping system diameter F
120	120	120	120	110		120	120	120	110	115	115		110	110	115	115	110	2/3	35 mm 锁紧系统直径 Clamping system diameter G
160	155									142	142		140	140	142	142		1	42 mm 锁紧系统直径 Clamping system diameter H
	155									190	190		200	200				2	48 mm 锁紧系统直径 clamping system diameter K
										190	190		200	200				2	锁紧系统直径 No clamping system N

PLE	PLQE	PLPE	PLHE	PLFE	WPLE	WPLOE	WPLPE	WPLFE	PSBN	PSN	PLN	PSFN	PLFN	WPLN	WGN	HLAE	输入系统 Input system
•	•	•	•	•	•	•	•	•	•	•	•	•	•	•	•	•	标准输入系统 Standard input system A
																•	可安装的驱动系统 Mountable input system S
															•	•	带有金属波纹管联轴器的输入系统 Input system with metal bellow-type coupling F
																	OP 25

PLE	PLQE	PLPE	PLHE	PLFE	WPLE	WPLOE	WPLPE	WPLFE	PSBN	PSN	PLN	PSFN	PLFN	WPLN	WGN	HLAE	输出法兰规格 Output flange design
•	•	•	•	•	•	•	•	•	•	•	•	•	•	•	•	•	标准输出法兰 Standard output flange 3
																	可兼容 (W) PLS 的输出法兰 Output flange (W) PLS-compatible 4
																	OP 14

PLE	PLQE	PLPE	PLHE	PLFE	WPLE	WPLOE	WPLPE	WPLFE	PSBN	PSN	PLN	PSFN	PLFN	WPLN	WGN	HLAE	输出轴规格 Output shaft design
•	•	•	•	•	•	•	•	•	•	•	•	•	•	•	•	•	OP 7 附带平键的输出轴 (DIN 6885-1) Output shaft with feather key (DIN 6885-1) A
•	•	•	•	•	•	•	•	•	•	•	•	•	•	•	•	•	OP 6 光滑输出轴 Smooth output shaft B
•	•	•	•	•	•	•	•	•	•	•	•	•	•	•	•	•	OP 26 花键输出轴 (DIN 5480) Toothed output shaft (DIN 5480) C
•	•	•	•	•	•	•	•	•	•	•	•	•	•	•	•	•	OP 27 法兰输出轴 Flange output shaft D
•	•	•	•	•	•	•	•	•	•	•	•	•	•	•	•	•	OP 27 带有配合销孔的法兰输出轴 Flange output shaft with dowel hole E
•	•	•	•	•	•	•	•	•	•	•	•	•	•	•	•	•	OP 24 单侧空心输出轴 Hollow output shaft on one side F
•	•	•	•	•	•	•	•	•	•	•	•	•	•	•	•	•	OP 24 双侧空心输出轴 Hollow output shaft on both sides G

PLE	PLQE	PLPE	PLHE	PLFE	WPLE	WPLOE	WPLPE	WPLFE	PSBN	PSN	PLN	PSFN	PLFN	WPLN	WGN	HLAE	表面 Surface
•	•	•	•	•	•	•	•	•	•	•	•	•	•	•	•	•	标准表面 Standard surface S

PLE	PLQE	PLPE	PLHE	PLFE	WPLE	WPLOE	WPLPE	WPLFE	PSBN	PSN	PLN	PSFN	PLFN	WPLN	WGN	HLAE	润滑 Lubrication
•	•	•	•	•	•	•	•	•	•	•	•	•	•	•	•	•	标准润滑 Standard lubrication S
•	•	•	•	•	•	•	•	•	•	•	•	•	•	•	•	•	OP 16 食品级润滑 Food grade lubrication F
•	•	•	•	•	•	•	•	•	•	•	•	•	•	•	•	•	OP 17 低温润滑 Low temperature lubrication L

PLE	PLQE	PLPE	PLHE	PLFE	WPLE	WPLOE	WPLPE	WPLFE	PSBN	PSN	PLN	PSFN	PLFN	WPLN	WGN	HLAE	回程间隙 Torsional backlash
•	•	•	•	•	•	•	•	•	•	•	•	•	•	•	•	•	标准回程间隙 Standard backlash S
																	OP 18 降低回程间隙 Reduced backlash R

分隔符 Separator

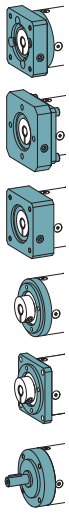

输入系统规格 Input design

		PLE	PLQE	PLPE	PLHE	PLFE	WPLE	WPLQE	WPLPE	WPLFE	
结构尺寸 (夹紧系统直径) Frame size (clamping system diameter)	Z 适配电机法兰 - 2 件式 - 圆形通用法兰 Motor adaptation - 2-part - round universal flange	60 (11/14) 80 (19) 120 (24)	60 (11/14) 80 (19) 120 (24)	70 (11/14) 90 (19) 120 (24)	60 (11/14) 80 (19) 120 (24)	64 (11/14) 90 (19) 110 (24)					
	Y 适配电机法兰 - 2 件式 - 正方形通用法兰 Motor adaptation - 2-part - square universal flange	40 (8/9/11) 60 (19) 80 (24) 120 (35) 160 (35)	60 (19) 80 (24) 120 (35)	50 (8/9/11) 70 (19) 90 (24) 120 (35) 155 (35/42)	60 (19) 80 (24) 120 (35)	64 (19) 90 (24) 110 (35)	40 (8/9) 60 (11/14) 80 (19) 120 (24)	60 (11/14) 80 (19) 120 (24)	50 (8/9) 70 (11/14) 90 (19) 120 (24)	64 (11/14) 90 (19) 110 (24)	
	E 适配电机法兰 - 单一法兰 Motor adaptation - one part	40 (8/9) 60 (11/14) 80 (19) 120 (24) 160 (35)	60 (11/14) 80 (19) 120 (24)	50 (8/9) 70 (11/14) 90 (19) 120 (24) 155 (35)	60 (11/14) 80 (19) 120 (24)	64 (11/14) 90 (19) 110 (24)					
	R 无适配电机法兰 - 圆形通用法兰 ¹⁾ No motor adaptation - round universal flange ¹⁾	60 (11/14) 80 (19) 120 (24)	60 (11/14) 80 (19) 120 (24)	70 (11/14) 90 (19) 120 (24)	60 (11/14) 80 (19) 120 (24)	64 (11/14) 90 (19) 110 (24)					
	T 无适配电机法兰 - 方形通用法兰 ¹⁾ No motor adaptation - square universal flange ¹⁾	40 (8/9/11) 60 (19) 80 (24) 120 (35) 160 (35)	60 (19) 80 (24) 120 (35)	50 (8/9/11) 70 (19) 90 (24) 120 (35) 155 (35/42)	60 (19) 80 (24) 120 (35)	64 (19) 90 (24) 110 (35)	40 (8/9) ³⁾ 60 (11/14) ⁴⁾ 80 (19) ⁴⁾ 120 (24) ⁴⁾	60 (11/14) ⁴⁾ 80 (19) ⁴⁾ 120 (24) ⁴⁾	50 (8/9) ³⁾ 70 (11/14) ⁴⁾ 90 (19) ⁴⁾ 120 (24) ⁴⁾	64 (11/14) ⁴⁾ 90 (19) ⁴⁾ 110 (24) ⁴⁾	
	W 无电机适配法兰 - 输入轴 ²⁾ No motor adaptation - input shaft ²⁾	40 (N) 60 (N) 80 (N) 120 (N) 160 (N)	60 (N) 80 (N) 120 (N)								

¹⁾ 产品代码在输入“电机轴直径”后结束 - The product code ends after “motor shaft diameter” has been entered
²⁾ 产品代码在该选项之后结束 - The product code ends after this option
³⁾ 仅带有通孔的直角齿轮箱 - Angle with through hole only
⁴⁾ 紧带有螺纹孔的直角齿轮箱 - Angle with thread only

电机轴直径 Motor shaft diameter

电机轴直径	Motor shaft diameter	8	9	11	14	19	24	35	42	48	对于“夹紧系统直径” For “clamping system diameter”
4	4 mm	•									
5	5 mm	•	•								
6	6 mm	•	•								
6.35	6,35 mm	•	•	•							
7	7 mm		•	•							
8	8 mm	•	•	•	•						
9	9 mm		•	•	•						
9.5	9,5 mm		•	•	•						
9.525	9,525 mm		•	•	•						
10	10 mm				•						
11	11 mm			•	•	•					
12	12 mm			•	•	•					
12.7	12,7 mm			•	•	•					
14	14 mm				•	•	•				
15.875	15,875 mm				•	•	•				
16	16 mm				•	•	•				
19	19 mm				•	•	•				
19.05	19,05 mm					•	•	•			
20	20 mm					•	•	•			
22	22 mm						•	•	•		
24	24 mm							•	•	•	
28	28 mm								•	•	
32	32 mm								•	•	
35	35 mm									•	•
38	38 mm										•
42	42 mm										•
48	48 mm										•

最大电机轴长 [mm] Max. motor shaft length [mm]

最大允许的电机轴长 Max. permissible motor shaft length 任意文本 - 长度数据无小数点 Free text - length without decimal places

定位凸台直径 [mm] Centering diameter [mm]

定位凸台直径 Centering diameter 任意文本 - 长度数据到小数点后两位 Free text - length to two decimal places

节圆直径 [mm] Pitch circle diameter [mm]

节圆直径 Pitch circle diameter 任意文本 - 长度数据到小数点后一位 Free text - length to one decimal place

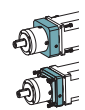

电机法兰类型 Flange type motor

电机法兰类型	Flange type motor	PLE	PLQE	PLPE	PLFE	WPLE	WPLQE	WPLPE	WPLFE	PSBN	PSN	PLN	PSFN	PLFN	WPLN	WGN	HLAE
B5	B5 电机法兰类型 B5 Flange type motor	•	•	•	•	•	•	•	•	•	•	•	•	•	•	•	•
B14	B14 电机法兰类型 B14 Flange type motor	•	•	•	•	•	•	•	•	•	•	•	•	•	•	•	•

请联系确认 Available upon inquiry

电机安装螺纹 Mounting thread

M2	M2	电机安装螺纹	Mounting thread
M3	M3	电机安装螺纹	Mounting thread
M4	M4	电机安装螺纹	Mounting thread
M5	M5	电机安装螺纹	Mounting thread
M6	M6	电机安装螺纹	Mounting thread
M8	M8	电机安装螺纹	Mounting thread
M10	M10	电机安装螺纹	Mounting thread
M12	M12	电机安装螺纹	Mounting thread
M16	M16	电机安装螺纹	Mounting thread

PLE060-008-SSSB3AC

参见前一页 See previous page

- E

9 / 20 / 40 / 63 / B5 / M5

PSBN	PSN	PLN	PSFN	PLFN	WPLN	WGN	HLAE	
70 (11/14/19) 90 (11/14/19/24) 115 (14/19/24/35)	70 (11/14/19) 90 (11/14/19/24) 115 (14/19/24/35) 142 (19/24/35/42) 190 (35/42/48)	70 (14/19) 90 (19/24) 115 (24)	64 (11/14/19) 90 (11/14/19/24) 110 (14/19/24/35) 140 (19/24/35/42) 200 (35/42/48)	64 (14/19) 90 (14/19/24) 110 (19/24) 140 (24) 200 (48)	70 (14/19) 90 (14/19/24) 115 (19/24) 142 (24)	70 (14/19) 90 (19/24) 115 (24)	70 (11/14) 90 (19) 110 (24)	
		115 (35) 142 (35/42) 190 (48)		110 (35) 140 (35/42) 200 (35/42)	115 (35) 142 (35/42)	115 (35) 142 (35/42)		
							70 (11/14) 90 (19) 110 (24)	
		70 (14/19) 90 (19/24) 115 (24)		64 (14/19) 90 (14/19/24) 110 (19/24) 140 (24) 200 (48)	70 (14/19) 90 (14/19/24) 115 (19/24) 142 (24)	70 (14/19) 90 (19/24) 115 (24)		OP 29
		115 (35) 142 (35/42) 190 (48)		110 (35) 140 (35/42) 200 (35/42)	115 (35) 142 (35/42)	115 (35) 142 (35/42)		OP 30
								OP 1

输入系统规格 Input design

电机轴直径 Motor shaft diameter

最大电机轴长 [mm] Max. motor shaft length [mm]

定位凸台直径 [mm] Centering diameter [mm]

节圆直径 [mm] Pitch circle diameter [mm]

电机法兰类型 Flange type motor

电机安装螺纹 Mounting thread

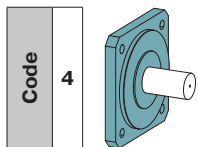

针对 PLN
For PLN

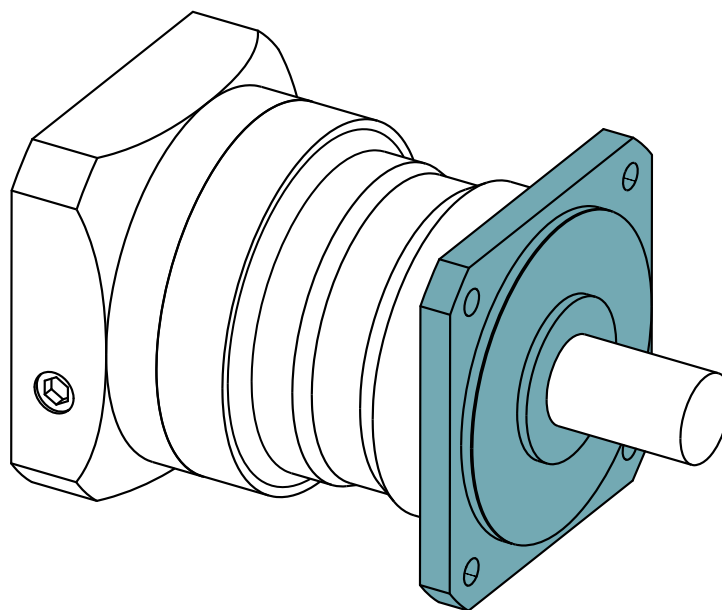

其他规格的减速机特点,输出轴负载,输出扭矩、输入速度和尺寸没有列在这里, 对应于细节在80到83页。

Other specifications for gearbox characteristics, output shaft loads, output torques, input speeds and dimensions not listed here correspond to the details on pages 80 to 83.

输入转速	Input speeds			PLN070	PLN090	PLN115	PLN142	PLN190	$i^{(1)}$	$z^{(2)}$
T _{2N} 和 S1 时的平均热输入转速 ⁽³⁾⁽⁴⁾	Average thermal input speed at T _{2N} and S1 ⁽³⁾⁽⁴⁾	n_{1N}	min ⁻¹	1850 ⁽⁵⁾	1800 ⁽⁵⁾	1400 ⁽⁵⁾	800 ⁽⁵⁾	650 ⁽⁵⁾	3	1
				2150 ⁽⁵⁾	1950 ⁽⁵⁾	1450 ⁽⁵⁾	850 ⁽⁵⁾	700 ⁽⁵⁾	4	
				2450 ⁽⁵⁾	2350 ⁽⁵⁾	1850 ⁽⁵⁾	950 ⁽⁵⁾	750 ⁽⁵⁾	5	
				3200 ⁽⁵⁾	3300 ⁽⁵⁾	2600 ⁽⁵⁾	1400 ⁽⁵⁾	1100 ⁽⁵⁾	7	
				3500 ⁽⁵⁾	3700 ⁽⁵⁾	2950 ⁽⁵⁾	1650 ⁽⁵⁾	1350 ⁽⁵⁾	8	
				4050 ⁽⁵⁾	4000 ⁽⁵⁾	3500 ⁽⁵⁾	2100 ⁽⁵⁾	1750 ⁽⁵⁾	10	
				3300 ⁽⁵⁾	3150 ⁽⁵⁾	2300 ⁽⁵⁾	1200 ⁽⁵⁾	950 ⁽⁵⁾	12	2
				3700 ⁽⁵⁾	3750 ⁽⁵⁾	2750 ⁽⁵⁾	1450 ⁽⁵⁾	1150 ⁽⁵⁾	15	
				3500 ⁽⁵⁾	3300 ⁽⁵⁾	2400 ⁽⁵⁾	1200 ⁽⁵⁾	1000 ⁽⁵⁾	16	
				4000 ⁽⁵⁾	3900 ⁽⁵⁾	2850 ⁽⁵⁾	1500 ⁽⁵⁾	1200 ⁽⁵⁾	20	
				4350 ⁽⁵⁾	4000 ⁽⁵⁾	3150 ⁽⁵⁾	1700 ⁽⁵⁾	1300 ⁽⁵⁾	25	
				4500 ⁽⁵⁾	4000	3500 ⁽⁵⁾	2100 ⁽⁵⁾	1750 ⁽⁵⁾	32	
				4500	4000	3500	2350 ⁽⁵⁾	1900 ⁽⁵⁾	40	
				4500	4000	3500	2950 ⁽⁵⁾	2400 ⁽⁵⁾	64	
				4500	4000	3500	3000	2500	100	

⁽¹⁾ 传动比 ($i=n_1/n_2$)

⁽²⁾ 减速机级数

⁽³⁾ 利用 NCP 针对应用设计转速 - www.neugart.com

⁽⁴⁾ 定义请参见第 128 页

⁽⁵⁾ 在 50% T_{2N} 输出和 S1 模式下的平均热传动转速

⁽¹⁾ Ratios ($i=n_1/n_2$)

⁽²⁾ Number of stages

⁽³⁾ Application-specific speed configurations with NCP - www.neugart.com

⁽⁴⁾ See page 129 for the definition

⁽⁵⁾ Average thermal input speed at 50% T_{2N} and S1

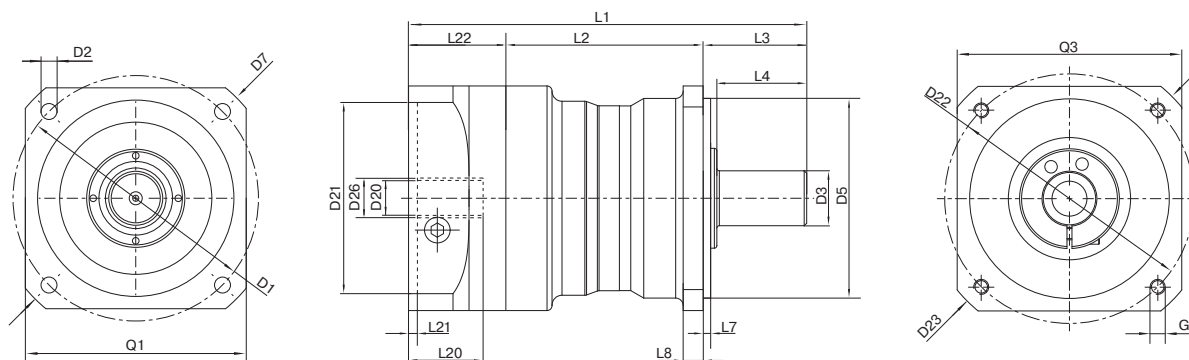

图示为带平键的 PLE060 / 1 级 / 附带平键的输出轴 / 可兼容 PLS 的输出法兰 / 19 mm 锁紧系统 / 适配电机法兰 - 单一法兰 / B5 电机法兰类型
 Drawing corresponds to a PLN090 / 1-stage / smooth output shaft / output flange PLS-compatible / 19 mm clamping system / motor adaptation - 2-part - round universal flange / B5 flange type motor
 所有其它变量可在 www.neugart.com 下 Tec Data Finder 中检索 - All other variants can be retrieved in the Tec Data Finder at www.neugart.com

几何尺寸 ⁽¹⁾	Geometry ⁽¹⁾			PLN070	PLN090	PLN115	PLN142	PLN190	z ⁽²⁾	Code
输出端安装孔节圆直径	Pitch circle diameter output	D1		75	100	130	165	215		
输出端安装孔直径	Mounting bore output	D2	4x	5,5	6,5	8,5	11,0	13,5		
输出轴直径	Shaft diameter output	D3	k6	19	22	32	40	55		
输出端定位凸台直径	Centering diameter output	D5	g7	60	80	110	130	160		
输出法兰对角线尺寸	Diagonal dimension output	D7		92	116	145	185	240		
输出端法兰外方	Flange cross section output	Q1	■	70	90	115	142	190		
最小总长	Min. total length	L1		138	160	201	276	311	1	
				167	192	241	335	383	2	
箱体长度	Housing length	L2		75	79	85	114,5	138	1	
				104	111	125	173,5	210	2	
输出轴轴长	Shaft length output	L3		32	41,5	64,5	87	90		
输出端定位凸台深度	Centering depth output	L7		3	3	4,5	5	6		
输出端法兰厚度	Flange thickness output	L8		7	8	10	20	20		
输入端锁紧系统直径	Clamping system diameter input	D26		更多信息见第 117 页 More information on page 117						
电机轴直径 j6/k6	Motor shaft diameter j6/k6	D20		具体尺寸视电机/减速机法兰而定。 可以在 www.neugart.com 下 Tec Data Finder. 中针对每个电机适配电机特有的输入法兰几何尺寸 The dimensions vary with the motor/gearbox flange. The input flange geometries can be retrieved for each specific motor in Tec Data Finder at www.neugart.com						
最大允许的电机轴长	Max. permis. motor shaft length	L20								
最小允许的电机轴长	Min. permis. motor shaft length									
输入端定位凹槽直径	Centering diameter input	D21								
输入端定位凹槽深度	Centering depth input	L21								
输入端安装孔节圆直径	Pitch circle diameter input	D22								
输入法兰长度	Motor flange length	L22								
输入法兰对角线尺寸	Diagonal dimension input	D23								
安装螺纹 x 深度	Mounting thread x depth	G3	4x							
输入端法兰外方	Flange cross section input	Q3	■							
附带平键的输出轴 (DIN 6885-1)	Output shaft with feather key (DIN 6885-1)			A 6x6x20	A 6x6x28	A 10x8x50	A 12x8x65	A 16x10x70		A
平键宽度 (DIN 6885-1)	Feather key width (DIN 6885-1)	B1		6	6	10	12	16		
含平键在内的轴高 (DIN 6885-1)	Shaft height including feather key (DIN 6885-1)	H1		21,5	24,5	35	43	59		
到轴肩的距离	Shaft length from shoulder	L4		28	36	58	80	82		
平键长度	Feather key length	L5		20	28	50	65	70		
到轴端的距离	Distance from shaft end	L6		6	4	4	8	6		
中心孔 (DIN 332, DR 形)	Center hole (DIN 332, type DR)	Z		M6x16	M8x19	M12x28	M16x36	M20x42		
光滑输出轴	Smooth output shaft									B
到轴肩的距离	Shaft length from shoulder	L4		28	36	58	80	82		

⁽¹⁾ 所有的尺寸单位为mm
⁽²⁾ 减速机级数

⁽¹⁾ Dimensions in mm
⁽²⁾ Number of stages

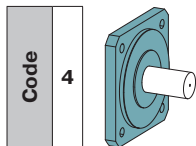

针对 WPLN
For WPLN

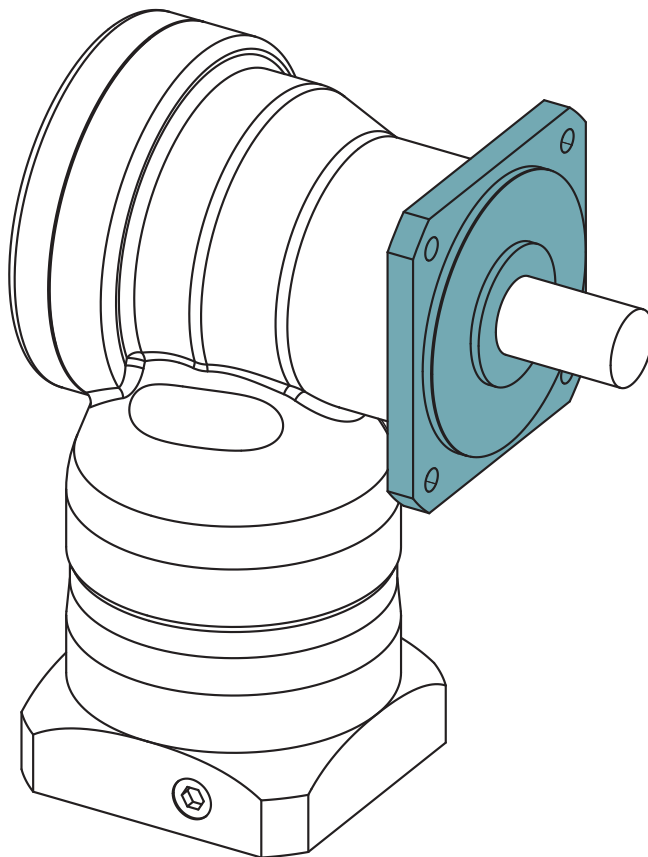

其他规格的变速箱特点,输出轴负载,输出扭矩、输入速度和尺寸没有列在这里, 对应于细节在98到101页。

Other specifications for gearbox characteristics, output shaft loads, output torques, input speeds and dimensions not listed here correspond to the details on pages 98 to 101.

输入转速	Input speeds			WPLN070	WPLN090	WPLN115	WPLN142	$i^{(1)}$	$Z^{(2)}$
T _{2N} 和 S1 时的平均热输入转速 ⁽³⁾⁽⁴⁾	Average thermal input speed at T _{2N} and S1 ⁽³⁾⁽⁴⁾	n_{1N}	min ⁻¹	1700 ⁽⁵⁾	1550 ⁽⁵⁾	1050 ⁽⁵⁾	900 ⁽⁵⁾	4	1
				1850 ⁽⁵⁾	1750 ⁽⁵⁾	1150 ⁽⁵⁾	950 ⁽⁵⁾	5	
				2200 ⁽⁵⁾	2100 ⁽⁵⁾	1350 ⁽⁵⁾	1000 ⁽⁵⁾	8	
				2300 ⁽⁵⁾	2200 ⁽⁵⁾	1400 ⁽⁵⁾	1050 ⁽⁵⁾	10	
				1700 ⁽⁵⁾	1650 ⁽⁵⁾	1550 ⁽⁵⁾	900 ⁽⁵⁾	16	2
				1850 ⁽⁵⁾	1900 ⁽⁵⁾	1800 ⁽⁵⁾	950 ⁽⁵⁾	20	
				2000 ⁽⁵⁾	2100 ⁽⁵⁾	2000 ⁽⁵⁾	1050 ⁽⁵⁾	25	
				2100 ⁽⁵⁾	2100 ⁽⁵⁾	2050 ⁽⁵⁾	1350 ⁽⁵⁾	32	
				2200 ⁽⁵⁾	2150 ⁽⁵⁾	2050 ⁽⁵⁾	1350 ⁽⁵⁾	40	
				2300 ⁽⁵⁾	2300 ⁽⁵⁾	2250 ⁽⁵⁾	1450 ⁽⁵⁾	50	
				2400 ⁽⁵⁾	2750 ⁽⁵⁾	2700 ⁽⁵⁾	1650 ⁽⁵⁾	64	
				2500 ⁽⁵⁾	2900 ⁽⁵⁾	2850 ⁽⁵⁾	1800 ⁽⁵⁾	100	

⁽¹⁾ 传动比 ($i=n_1/n_2$)

⁽²⁾ 减速机级数

⁽³⁾ 利用 NCP 针对应用设计转速 – www.neugart.com

⁽⁴⁾ 定义请参见第 128 页

⁽⁵⁾ 在 50% T_{2N} 输出和 S1 模式下 的平均热传动转速

⁽¹⁾ Ratios ($i=n_1/n_2$)

⁽²⁾ Number of stages

⁽³⁾ Application-specific speed configurations with NCP – www.neugart.com

⁽⁴⁾ See page 129 for the definition

⁽⁵⁾ Average thermal input speed at 50% T_{2N} and S1

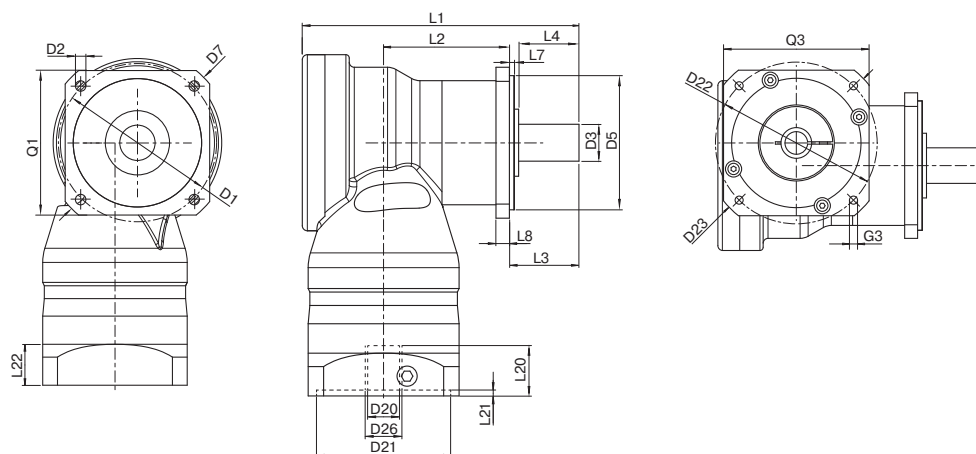

图示为带平键的WPLN090 / 1 / 光滑输出轴 / 可兼容WPLS的输出法兰 / 14 mm 锁紧系统 / 适配电机法兰 - 2 件式 - 圆形通用法兰 / B5 电机法兰类型

Drawing corresponds to a WPLN090 / 1-stage / smooth output shaft / output flange WPLS-compatible / 14 mm clamping system / motor adaptation - 2-part - round universal flange / B5 flange type motor
 所有其它变量可在 www.neugart.com 下 Tec Data Finder 中检索 - All other variants can be retrieved in the Tec Data Finder at www.neugart.com

几何尺寸 ⁽¹⁾	Geometry ⁽¹⁾			WPLN070	WPLN090	WPLN115	WPLN142	z ⁽²⁾	Code
输出端安装孔节圆直径	Pitch circle diameter output	D1		75	100	130	165		
输出端安装孔直径	Mounting bore output	D2	4x	5,5	6,5	8,5	11,0		
输出轴直径	Shaft diameter output	D3	k6	19	22	32	40		
输出端定位凸台直径	Centering diameter output	D5	g7	60	80	110	130		
输出法兰对角线尺寸	Diagonal dimension output	D7		92	116	145	185		
输出端法兰外方	Flange cross section output	Q1	■	70	90	115	142		
总长	Total length	L1		137,5	165	218	273	1	
				185	207	248,5	342,5	2	
箱体长度	Housing length	L2		62,5	75	97	99	1	
				110	122,5	135,5	199	2	
输出轴轴长	Shaft length output	L3		32	41,5	64,5	87		
输出端定位凸台深度	Centering depth output	L7		3	3	4,5	5		
输出端法兰厚度	Flange thickness output	L8		7	8	10	20		
输入端锁紧系统直径	Clamping system diameter input	D26		更多信息见第 117 页 More information on page 117					
电机轴直径 j6/k6	Motor shaft diameter j6/k6	D20		具体尺寸视电机/减速机法兰而定。 可以在 www.neugart.com 下 Tec Data Finder. 中针对每个电机适配电机特有的输入法兰几何尺寸 The dimensions vary with the motor/gearbox flange. The input flange geometries can be retrieved for each specific motor in Tec Data Finder at www.neugart.com					
最大允许的电机轴长	Max. permis. motor shaft length	L20							
最小允许的电机轴长	Min. permis. motor shaft length								
输入端定位凹槽直径	Centering diameter input	D21							
输入端定位凹槽深度	Centering depth input	L21							
输入端安装孔节圆直径	Pitch circle diameter input	D22							
输入法兰长度	Motor flange length	L22							
输入法兰对角线尺寸	Diagonal dimension input	D23							
安装螺纹 x 深度	Mounting thread x depth	G3	4x						
输入端法兰外方	Flange cross section input	Q3	■						
附带平键的输出轴 (DIN 6885-1)	Output shaft with feather key (DIN 6885-1)			A 6x6x20	A 6x6x28	A 10x8x50	A 12x8x65		A
平键宽度 (DIN 6885-1)	Feather key width (DIN 6885-1)	B1		6	6	10	12		
含平键在内的轴高 (DIN 6885-1)	Shaft height including feather key (DIN 6885-1)	H1		21,5	24,5	35	43		
到轴肩的距离	Shaft length from shoulder	L4		28	36	58	80		
平键长度	Feather key length	L5		20	28	50	65		
到轴端的距离	Distance from shaft end	L6		4	4	4	8		
中心孔 (DIN 332, DR 形)	Center hole (DIN 332, type DR)	Z			M6x16	M8x19	M12x28	M16x36	
光滑输出轴	Smooth output shaft								
到轴肩的距离	Shaft length from shoulder	L4		28	36	58	80		

⁽¹⁾ 所有的尺寸单位为mm
⁽²⁾ 减速机级数

⁽¹⁾ Dimensions in mm
⁽²⁾ Number of stages

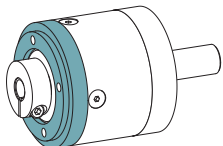

无适配电机法兰 – 圆形通用法兰

No motor adaptation – round universal flange

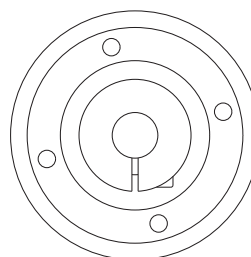
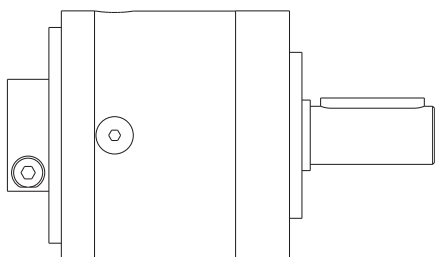

图示为带平键的 PLE060 / 1 级 / 附带平键的输出轴 / 11 mm 锁紧系统 / 无适配电机法兰 – 圆形通用法兰
 Drawing corresponds to a PLE060 / 1-stage / output shaft with feather key / 11 mm clamping system / no motor adaptation – round universal flange
 所有其它变量可在 www.neugart.com 下 Tec Data Finder 中检索 – All other variants can be retrieved in Tec Data Finder at www.neugart.com

这种输入系统的设计所适用的产品系列，规格尺寸和相关的锁紧系统会在117-119页的产品编码显示。
 相应尺寸请在 www.neugart.com 的 Tec Data Finder 中查询

This input design applies to the series, frame sizes, and associated clamping systems shown in the product code on pages 117-119.

The respective measurements can be taken from the dimension sheets in Tec Data Finder at www.neugart.com

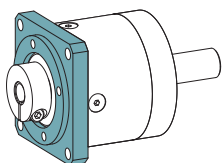
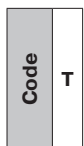

无适配电机法兰 – 方形通用法兰

No motor adaptation – square universal flange

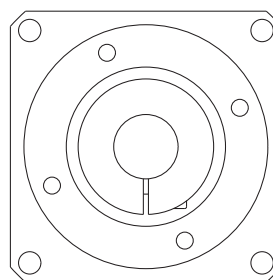
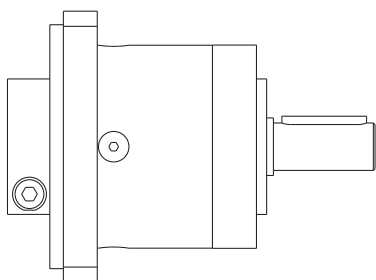

图示为带平键的 PLE060 / 1 级 / 附带平键的输出轴 / 19 mm 锁紧系统 / 无适配电机法兰 – 正方形通用法兰
 Drawing corresponds to a PLE060 / 1-stage / output shaft with feather key / 19 mm clamping system / no motor adaptation – square universal flange
 所有其它变量可在 www.neugart.com 下 Tec Data Finder 中检索 – All other variants can be retrieved in Tec Data Finder at www.neugart.com

这种输入系统的设计所适用的产品系列，规格尺寸和相关的锁紧系统会在117-119页的产品编码显示。
 相应尺寸请在 www.neugart.com 的 Tec Data Finder 中查询。

This input design applies to the series, frame sizes, and associated clamping systems shown in the product code on pages 117-119.

The respective measurements can be taken from the dimension sheets in Tec Data Finder at www.neugart.com

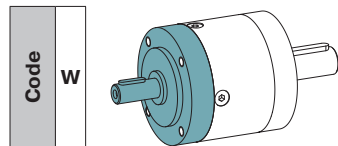

针对 PLE 和 PLQE
For PLE and PLQE

未列出的减速机参数请参见 16 至 25 页中的数据。- 这种减速机必须在输入端和输出端都配有法兰

Gearbox characteristics not listed here correspond to the details on pages 16 to 25 - The gearboxes have to be flanged on input and output flange

输出轴载荷	Output shaft loads			PLE040	PLE060	PLE080	PLE120	PLE160	z ⁽¹⁾	Code
					PLQE060	PLQE080	PLQE120			
输入径向力在10,000小时 ⁽²⁾	Radial force input 10,000 h ⁽²⁾	F _{r input}	N	100	250	450	1000	1400		W
输入轴向力在10,000小时 ⁽²⁾	Axial force input 10,000 h ⁽²⁾	F _{a input}		120	300	500	1300	1600		

转动惯量	Moment of inertia			PLE040	PLE060	PLE080	PLE120	PLE160	z ⁽¹⁾	Code	
					PLQE060	PLQE080	PLQE120				
转动惯量 ⁽³⁾	Mass moment of inertia ⁽³⁾	J	kgcm ²		0,011	0,049	0,269	1,034	2,795	1	W
					0,020	0,107	0,587	1,795	8,999		
					0,011	0,050	0,274	1,061	2,627	2	
					0,020	0,092	0,469	1,719	7,565		
					0,011	0,048	0,267	1,032	-	3	
					0,019	0,057	0,443	1,647			

输入转速	Input speeds			PLE040	PLE060	PLE080	PLE120	PLE160	z ⁽¹⁾	Code
					PLQE060	PLQE080	PLQE120			
最高机械输入转速 ⁽⁴⁾	Max. mechanical input speed ⁽⁴⁾	n _{1Limit}	min ⁻¹	18000	13000	7000	6500	4500		W

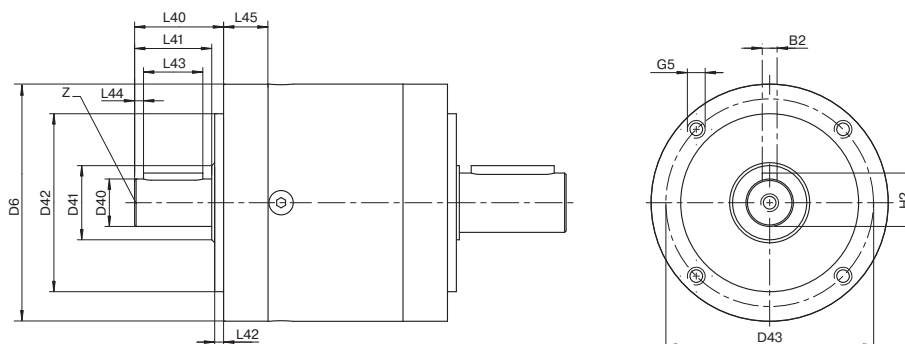

图示为带平键的 PLE080 / 1 级 / 附带平键的输出轴 / 输入轴 - Drawing corresponds to a PLE080 / 1-stage / output shaft with feather key / input shaft
所有其它变量可在 www.neugart.com 下 Tec Data Finder 中检索 - All other variants can be retrieved in Tec Data Finder at www.neugart.com

几何尺寸 ⁽⁵⁾	Geometry ⁽⁵⁾			PLE040	PLE060	PLE080	PLE120	PLE160	z ⁽¹⁾	Code
					PLQE060	PLQE080	PLQE120			
平键宽度 (DIN 6885-1)	Feather key width (DIN 6885-1)	B2		2	3	5	6	10	W	
箱体直径	Housing diameter	D6		40	60	80	115	160		
输入轴直径	Shaft diameter input	D40	j6	8	10	16	20	35		
输入轴轴肩直径	Shaft collar input	D41		12	17	25	35	55		
输入端定位凹槽直径	Centering diameter input	D42	h7	26	40	60	80	110		
输入端安装孔节圆直径	Pitch circle diameter input	D43		34	52	70	100	130		
安装螺纹 x 深度	Mounting thread x depth	G5	4x	M4x6	M5x8	M6x10	M10x16	M10x25		
含平键在内的轴高 (DIN 6885-1)	Shaft height including feather key (DIN 6885-1)	H2		8,8	11,2	18,0	22,5	38,0		
输入轴轴长	Shaft length input	L40		20	28	30	45	65		
到轴肩的距离	Shaft length from shoulder	L41		17	23	26	40	58		
输入端定位凹槽深度	Centering depth input	L42		2	3	3	4	5		
输入端平键长度	Feather key length input	L43		12	18	20	32	45		
输入端至轴端距离	Distance from shaft end input	L44		2,5	2,5	3,0	4,0	7,0		
输入法兰厚度	Flange thickness input	L45		10,2	12,7	15,0	31,0	58,0		
中心孔 (DIN 332, DR 形)	Center hole (DIN 332, type DR)	Z		M3x9	M3x9	M5x12	M6x16	M12x28		

(1) Number of stages

(2) Based on center of shaft at n₁=1000转/分

(3) The ratio-dependent values can be retrieved in Tec Data Finder - www.neugart.com

(4) Allowed operating temperature must be kept; other input speeds available on inquiry

(5) Dimensions in mm

(1) 减速机级数

(2) 沿着轴心且 最小转数 n₁=1000转/分⁻¹

(3) 传动比相关的数值可在 Tec Data Finder 中检索 - www.neugart.com

(4) 必须保证允许的工作温度; 特殊的输入转速请联系确认

(5) 所有的尺寸单位为mm

WGN 涨紧套
WGN Shrink disc

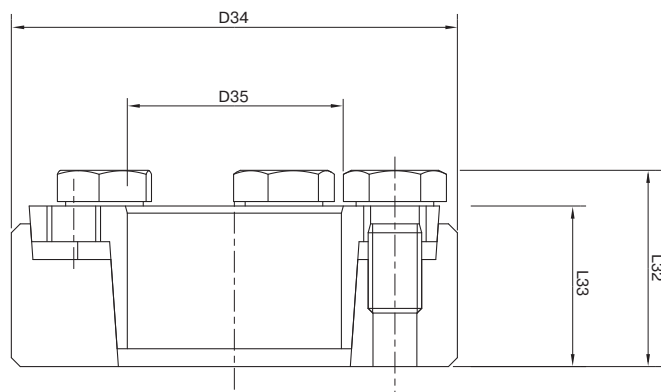

此涨紧套可以通过涨紧力锁紧的方式连接您的设备轴与WGN直角减速机中空输出轴。

This shrink disc can be used to make a force-fit connection between your machine shaft and the right angle hollow shaft gearbox WGN.

				WGN070	WGN090	WGN115	WGN142
产品编号	Art. No.			58365	58366	58367	58368
外径	Outside diameter	D34	mm	44	50	72	90
内径	Inner diameter	D35		18	24	36	50
总长 ⁽¹⁾	Overall length ⁽¹⁾	L32		19	22	27,3	31,3
夹紧长度 ⁽¹⁾	Clamp length ⁽¹⁾	L33		15	18	22	26
对边宽度	Width across flats	SW30		10	10	13	13
夹紧螺钉数量	Number of clamp screws	N30		4	5	5	8
转动惯量	Mass moment of inertia	J	kgcm ²	0,4251	0,7831	4,212	11,55

建议承载轴公差为 h6，表面粗糙度 Ra < 3,2 μm. CAD数据下载地址: www.neugart.com

For the load shaft, we recommend a tolerance of h6 and a surface roughness of Ra < 3.2 μm. CAD data can be accessed at www.neugart.com

关于涨紧套的安装步骤，请参考相应的安装说明 (www.neugart.com)。

For correct installation of the shrink disc, please refer to the corresponding mounting instructions (www.neugart.com)

供货范围

1 x 涨紧套 (含螺钉)

Scope of delivery

1 x Shrink disc (incl. screws)

⁽¹⁾ 未夹紧状态下的尺寸

⁽¹⁾ Dimensions in unclamped state

HLAE 密封套件
HLAE Sealing kit

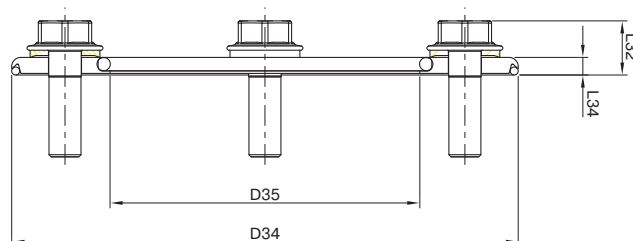

HLAE 配有可自由安装的密封套件可提供最大程度的卫生级保护，并可普遍适用于不同的壁厚。即为设备提供了最大程度的灵活性，同时又能满足最严格的卫生级别要求。

The freely positionable sealing kit for the HLAE provides maximum hygienic protection, making it universally suitable for different wall thicknesses. It therefore gives you maximum flexibility for connecting to the machine while satisfying the strictest hygienic requirements.

				HLAE070	HLAE090	HLAE110
产品编号	Art. No.			63911	63858	64130
外径	Outside diameter	D34	mm	75	95	120
内径	Inner diameter	D35		40	58	65
总长	Overall length	L32		8,5	9,5	11,5
垫片长度	Disc length	L34		3	3	3
对边宽度	Width across flats	SW30		8	10	13
数量 x 螺钉 x 长度	Quantity x screw x length	G30		4 x M5x16	4 x M6x20	4 x M8x25

关于密封套件的安装步骤，请参考相应的安装说明(www.neugart.com)。

For correct installation of the sealing kit, please refer to the corresponding mounting instructions (www.neugart.com)

供货范围

- 1 x 不锈钢电解抛光垫片
- 1 x EPDM 密封圈(针对设备应用的密封件)
- 1 x EPDM 密封圈(针对减速机的密封件)
- 4 x USIT-VA 包括带 EPDM 涂层的密封垫片，符合 EHEDG标准
- 4 x 卫生型设计不锈钢螺钉（电解抛光），符合 EHEDG标准

Scope of delivery

- 1 x electropolished stainless steel disc
- 1 x EPDM sealing ring (seal to application)
- 1 x EPDM sealing ring (seal to gearbox)
- 4 x USIT-VA with EPDM coated sealing washer, EHEDG-compliant
- 4 x Hygienic Design stainless steel screw (electropolished), EHEDG-compliant

最大可传递输出转矩

最大的可传递输出扭矩

计算变速器齿部的使用寿命时，需区分疲劳强度和持久强度。参见图表

疲劳强度

所有 Neugart 公司的行星齿轮变速器都是专为高耐久性的使用条件而设计的（在规定的额定扭矩 T_{2N} 之内）。

可随时达到指定的负载数据，变速器齿部不会出现故障。

持久强度

基于指定的额定扭矩 T_{2N} ，进行断续运行时，还可以传输短时间的扭矩峰值或过高的使用扭矩。

最大使用扭矩 $T_{2\text{施用}}$ 的计算

- * 出现过高的使用扭矩时确定“输出轴转数”的总和。
- * 通过图表得出最大增强系数 f 。
- * 可算出最大可传输的使用扭矩 $T_{2\text{max_允许_使用}}$

$$T_{2\text{max_允许_使用}} = f \times T_{2N}$$

- * 最大使用扭矩 $T_{2\text{施用}}$ 不得超过已得出的变速器最大输出扭矩 $T_{2\text{max_允许_使用}}$ 。

$$T_{2\text{max_允许_使用}} \geq T_{2\text{施用}}$$

增强系数 f 取决于“输出轴转数”的总和

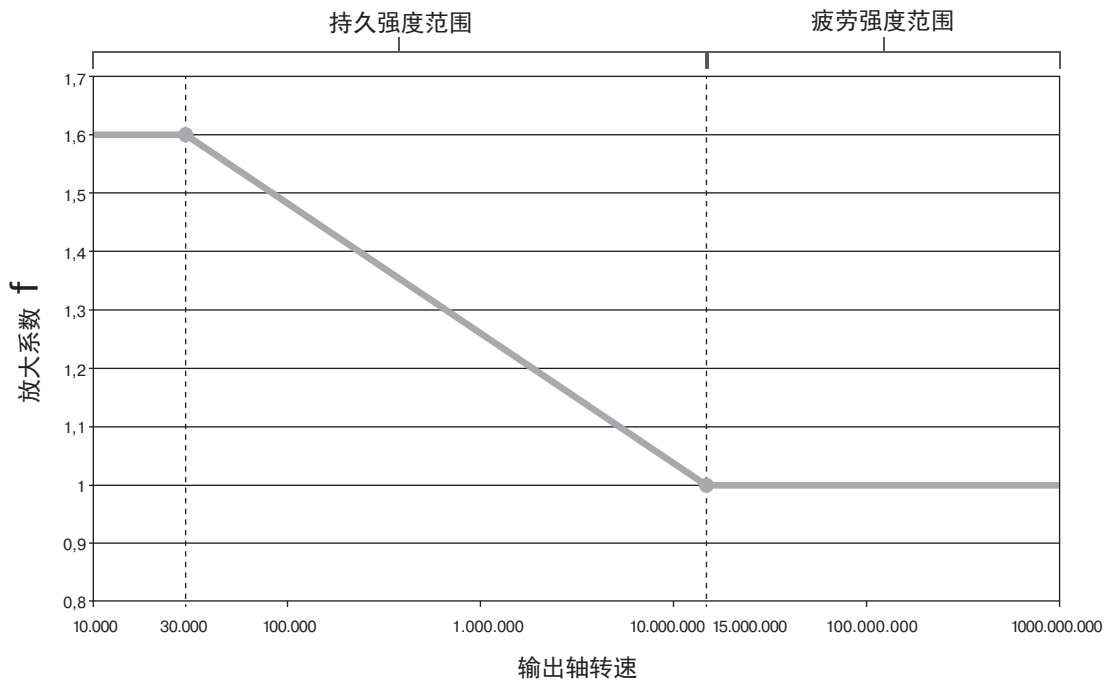

环境条件

用于散热设计的以下环境条件是设置目录值的基础：

- * 发动机不需要加热变速器
- * 凸缘板（施用侧）：
 - 方形的平板 = 2 x 减速机输出端法兰外方尺寸
 - 材料：钢
- * 机座上的板连接：单侧 20°C
- * 不妨碍变速器的对流
- * 环境温度：20°C

利用 NCP 针对应用进行专门设计 – www.neugart.com

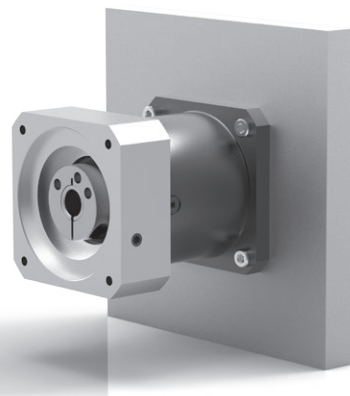

Max. transferable output torque

Calculations of gear teeth service lives differentiate between long life and finite life. See diagram.

Long life

All Neugart planetary gearboxes are designed for the long life range within the specified nominal torques T_{2N} . The load specifications can be reached any number of times without the gear teeth failing.

Finite life

Intermittent duty may transfer brief torque peaks or increased application factors that exceed the specified nominal torque T_{2N} .

Calculating the max application torque $T_{2\text{application}}$

- * The total output shaft rotations under the increased application torques are determined.
- * The resulting max increase factor f is determined from the diagram.
- * The max transferable application torque $T_{2\text{max_application}}$ is calculated:

$$T_{2\text{max_application}} = f \times T_{2N}$$

- * The application torque $T_{2\text{application}}$ may not exceed the gearbox's calculated max application torque $T_{2\text{max_application}}$

$$T_{2\text{max_application}} \geq T_{2\text{application}}$$

Increase factor f as a function of the total "output shaft rotations"

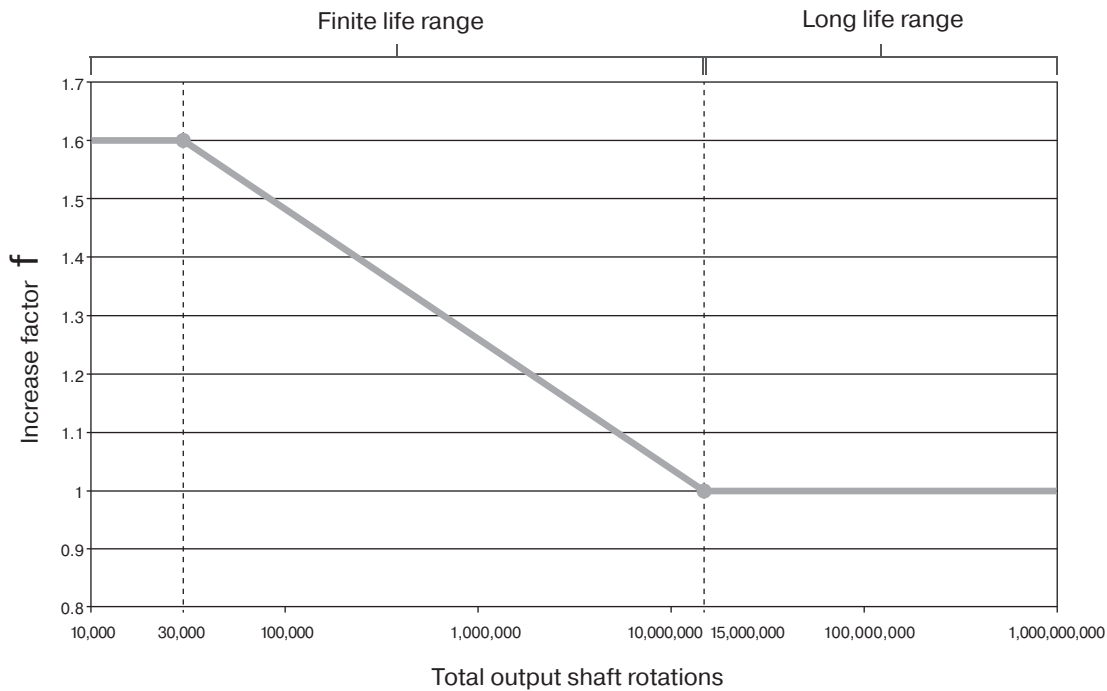

Ambient conditions

The following ambient conditions for the thermal design serve as the basis for the catalog values:

- * The motor does not heat up the gearbox
- * Flange mounted plate (application side):
 - Square plate = 2 x gearbox flange cross section at output
 - Material: steel
- * Plate connected via machine bed: 20°C on one side
- * No hindrance to gearbox convection
- * Ambient temperature: 20°C

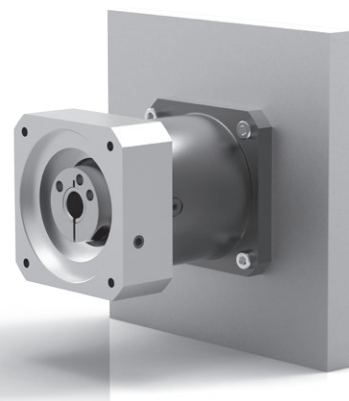

Application specific configuration with NCP – www.neugart.com

集团总部

Group Headquarters

Neugart GmbH
Keltenstraße 16
D-77971 Kippenheim
Phone: +49 7825 847-0
Fax: +49 7825 847-2999
Email: sales@neugart.com
Web: www.neugart.com

中国分公司

China Headquarters

Neugart Planetary Gearboxes (Shenyang)
Co., Ltd.
10A No. 2, No. 8 Road
E&T Development Zone Shenyang,
PC 110141 PR China
Phone: +86 24 2537-4959
Fax: +86 24 2537-2552
Email: sales@neugart.net.cn
Web: www.neugart.net.cn

德国

Baden-Wuerttemberg

B & K Antriebstechnik GmbH
Anhauser Str. 76
89547 Gerstetten-Dettingen
Phone: +49 7324 91012-0
Fax: +49 7324 91012-25
Email: info@b-k-antriebstechnik.de
Web: www.b-k-antriebstechnik.de

德国

Bavaria

Helmut Schwarz
85241 Unterweilbach
Phone: +49 171 7587709
Fax: +49 7825 847-2999
Email: helmut.schwarz@neugart.com
Web: www.neugart.com

德国

Bavaria

Helmut Feicht
85258 Weichs
Phone: +49 151 18812757
Fax: +49 7825 847-2999
Email: helmut.feicht@neugart.com
Web: www.neugart.com

德国/德国

Central Germany / Western Germany

Alexander Schmidt
D-77971 Kippenheim
Phone: +49 151 18812750
Fax: +49 7825 847-2999
Email: alexander.schmidt@neugart.com
Web: www.neugart.com

德国/德国

Northern Germany/Western Germany

Marco Stührenberg
33659 Bielefeld
Phone: +49 151 18812751
Fax: +49 7825 847-2999
Email: marco.stuehrenberg@neugart.com
Web: www.neugart.com

比利时/Belgium

Automotion
Bilksken 36
B-9920 Lovendegem
Phone: +32 93 705555
Fax: +32 93 705550
Email: info@automotion.be
Web: www.automotion.be

比利时/Belgium

Caldic Techniek Belgium NV SA
Tollaen 73 Avenue du Péage
B-1932 Sint Stevens Woluwe
Phone: +32 2720 49 81
Fax: +32 2720 81 01
Email: infobelgium@caldic-techniek.be
Web: www.caldic.com

丹麦/Denmark

ServoTech A/S
Ulvehavevej 44B
DK-7100 Vejle
Phone: +45 7942 80 80
Email: sales@servotech.dk
Web: www.servotech.dk

芬兰/Finland

Oy Movetec Ab
Hannuksentie 1
FIN-02270 Espoo
Phone: +358 9 5259-230
Fax: +358 9 5259-2333
Email: info@movetec.fi
Web: www.movetec.fi

法国/France

Atlanta Neugart France S.A.R.L.
9, Rue Georges Charpark
F-77127 Lieusaint
Phone: +33 1640 53616
Fax: +33 1640 53617
Email: info@atlanta-neugart.com
Web: www.atlanta-neugart.com

希腊/Greece

gt-kyma
D. Papatthanasiou
69 Ampelokipi
GR-54629 Thessaloniki
Phone: +302 310 786 002
Email: info@gt-kyma.com
Web: www.gt-kyma.com

英国/United Kingdom

HMK Technical Services Ltd.
Kappa House, Hatter Street
Congleton
GB-Cheshire CW 12 1 Q1
Phone: +44 1260 279411
Fax: +44 1260 281022
Email: sales@hmkdirect.com
Web: www.hmkdirect.com

意大利/Italy

Neugart Italia S.r.l.
Corso Matteotti 30
I-10121 Torino
Phone: +39 011 640 8248
Fax: +39 011 640 6205
Cell: +39 335 8088612
Email: loris.mazzetto@neugart.com
Web: www.neugartitalia.it

荷兰/Netherlands

Caldic Techniek b.v.
Schuttevaerweg 60
NL-3044BB-Rotterdam
Phone: +31 104 156622
Fax: +31 104 378810
Email: aandrijf@caldic-techniek.nl
Web: www.caldic.com

荷兰/Netherlands

ABI b.v.
Aandrijf-en besturingstechniek
A. Hofmanweg 60
NL-2031 BL Haarlem
Phone: +31 23 531 9292
Fax: +31 23 532 6599
Email: info@abi.nl
Web: www.abi.nl

奥地利/Austria

TAT TECHNOM Antriebstechnik GmbH
Technologiering 13 - 17
A-4060 Leonding
Phone: +43 7229 64840-0
Fax: +43 7229 64840-99
Email: tat@tat.at
Web: www.tat.at

波兰/Poland

P.P.H. WObit E.K.J. Ober s.c.
Dęboryce 16
62-045 Pniewy
Phone: +48 61 2227-422
Fax: +48 61 2227-439
Email: wobit@wobit.com.pl
Web: www.wobit.com.pl

瑞典/Sweden

SDT Scandinavian Drive Technologies
Sabelgatan 4
S-25467 Helsingborg
Phone: +46 42 380800
Fax: +46 42 380813
Email: info@sdt.se
Web: www.sdt.se

瑞士/Switzerland

Relex AG
Antriebstechnik
Schachenstrasse 80
CH-8645 Jona SG
Phone: +41 55 2254611
Fax: +41 55 2254619
Email: info@relex.ch
Web: www.relex.ch

西班牙/Spain

Brotomatic, S.L.
Poligono de Ali-Gobeo
C/San Miguel de Acha, 2-Pab3
01010 Vitoria-Gasteiz (Álava)
Phone: +34 945 249411, 24977
Fax: +34 945 227832
Email: broto@brotomatic.es
Web: www.brotomatic.es

捷克/Czech Republic

TAT – POHONOVÁ TECHNIKA s.r.o.
Hranicni 2253
CZ-370 06 Ceske Budejovice
Phone: +420 387 414-414
Fax: +420 387 414-415
Email: tat@cz.tat.at
Web: www.tat.cz

巴西/阿根廷 **Brazil/Argentina**

Neugart do Brasil
Equipamentos Industriais Ltda
Aceso José Sartorelli, km 2, 1 -
Parque das Árvores
SP CEP 18550-000 Boituva
Phone: +55 15 3363-9910
Fax: +55 15 3363-9911
Email: comercial@neugart.com.br
Web: www.neugart.com.br

马来西亚/Malaysia

Aims Motion Technology Son Bhd.
No. 19, Jalan Industri PBP 8,
Taman Industri Pusat Bandar Puchong,
47100 Puchong, Selangor,
Malaysia.
Phone: +6 03 5882-1896
Fax: +6 03 5882-1845
Email: chwong@aimsmotion.com.my
Web: www.aimsmotion.com.my

土耳其/Turkey

Neugart Redüktör San. Tic. Ltd. Şti
Burhaniye Mah. Atilla Sk. No:12
81210 Beylerbeyi – Üsküdar / İstanbul
Phone: +90) 216 639 4050
Fax: +90) 216 639 4052
Email: sales@neugart.com.tr
Web: www.neugart.com.tr

印度/India

Fluro Engineering PVT. Ltd.
Plot No.B-29/1
MIDC,Taloja
Dist: Raigad (Navi Mumbai)-410208
Maharashtra India
Phone: +91 22 2741-1922, 2740-1153
Fax: +91 22 2741-1933
Email: sales@fluroengg.com
Web: www.fluroengg.com

韩国/South Korea

Intech Automation Inc.
2-1504, Ace Hitech City
55-20 Mullaee-Dong 3-Ga,
Youngdeungpo-Ku, Seoul, Korea, 150-972
Phone: +82 2 3439-0070
Fax: +82 2 3439-0080
Email: intech@intechautomation.co.kr
Web: www.intechautomation.co.kr

美国/加拿大 **USA/Canada**

Neugart USA Corp.
14325 South Lakes Drive
Charlotte, NC 28273, USA
Phone: +1 980 299-9800
Fax: +1 980 299-9799
Email: sales@neugartusa.com
Web: www.neugartusa.com

以色列/Israel

SUZIN TRANSMISSION SYSTEM LTD.
Motion control & transmission technology
4 Ha'peles Str. – Bldg. 11
Gav-Yam ind. Park
Haifa, Israel
Phone: +972 4 8724148, 8725708
Fax: +972 4 8414284
Email: info@suzin.co.il
Web: www.suzin.co.il

台湾/Taiwan

Alteks Co., Ltd.
5F, 580, Sec. 1, Min-Sheng N. Road,
Kuei-Shan Hsiang,
Taoyuan Hsien,
Phone: +886 886 3 2121-020
Fax: +886 886 3 2121-250
Email: cd.yeh@msa.hinet.net
Web: www.alteks.com.tw



Neugart Planetary Gearboxes (Shenyang) Co., Ltd.

纽卡特行星减速机（沈阳）有限公司

电话：+86 24 2537-4959

传真：+86 24 2537-2552

网址：www.neugart.net.cn

邮箱：sales@neugart.net.cn